

NOTES CONTINUED:
 5. SCRIBE, ENGRAVE, OR MECHANICALLY STAMP (NO INKS OR DYES) DRAWING PART NUMBER, REVISION (AND VARIANT OR TYPE IF APPLICABLE) ON NOTED SURFACE OF PART FOLLOWED ON THE NEXT LINE WITH A THREE DIGIT SERIAL NUMBER. SERIAL NUMBERS START AT 001 FOR THE FIRST ARTICLE AND PROCEED CONSECUTIVELY. USE MINIMUM 0.12" HIGH CHARACTERS. UNLESS THE SIZE OF THE PART DICTATES SMALLER CHARACTERS. A VIBRATORY TOOL MAY BE USED. EXAMPLE: DXXXXXX-VY, TYPE-XX, S/N XXX

- 6. APPROXIMATE WEIGHT = 1.176 LB.
- 7. MACHINE ALL SURFACES TO REMOVE OXIDES AND MILL FINISH, USE OF ABRASIVE REMOVAL TECHNIQUES IS NOT ALLOWED.
- 8. ALL PARTS SHALL BE MANUFACTURED IN ACCORDANCE WITH LIGO SPECIFICATION E0900364
- 9. ALL HELI-COIL HOLES TO BE PREPARED ACCORDING TO EMHART HELI-COIL PRODUCT CATALOG, HC2000, REV 4
- 10. ALL HELI-COIL INSERTS TO BE INSTALLED BY LIGO PERSONNEL, AFTER DELIVERY OF FINISHED PARTS, USE NITRONIC 60 THREADED INSERTS.

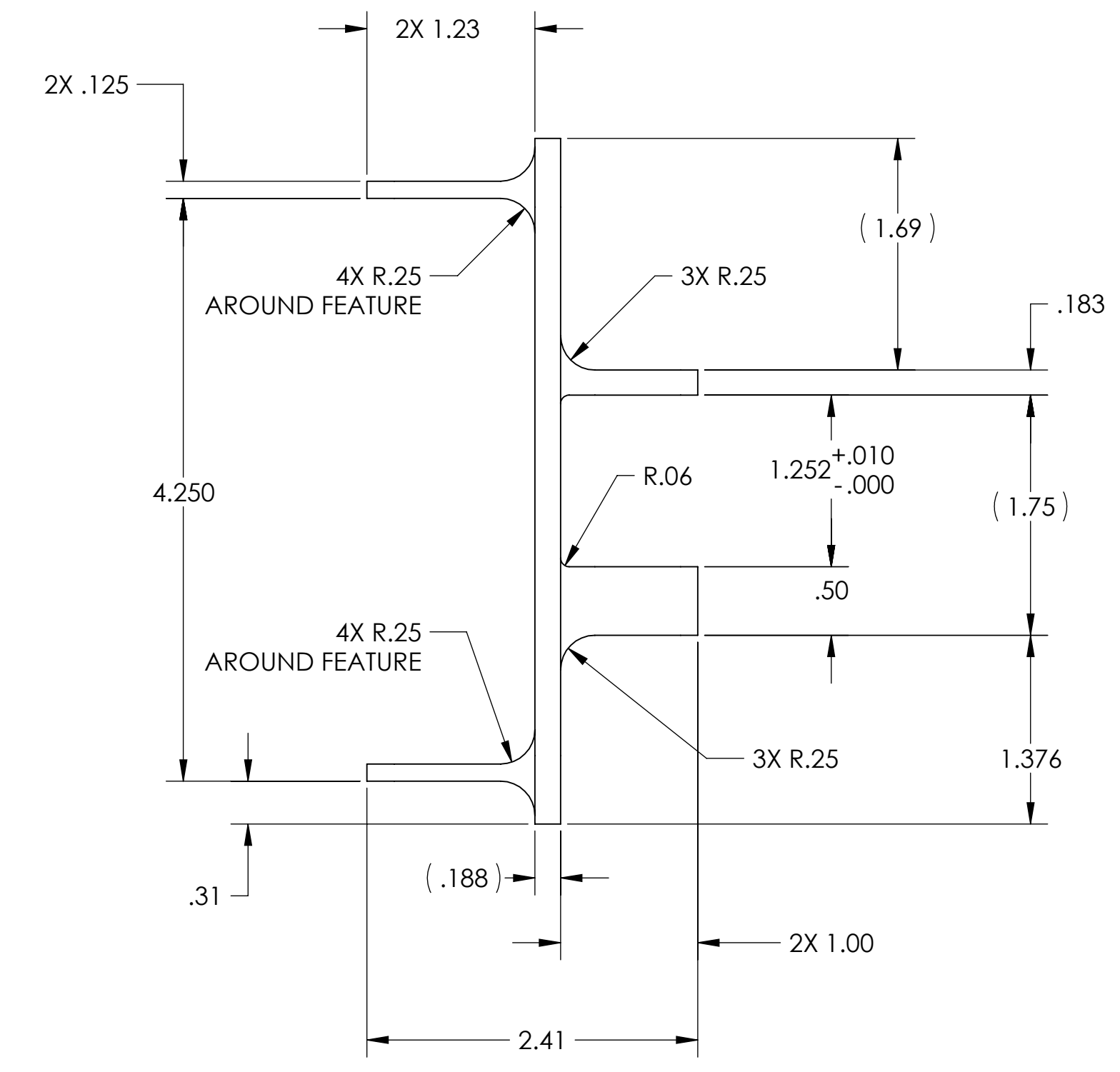
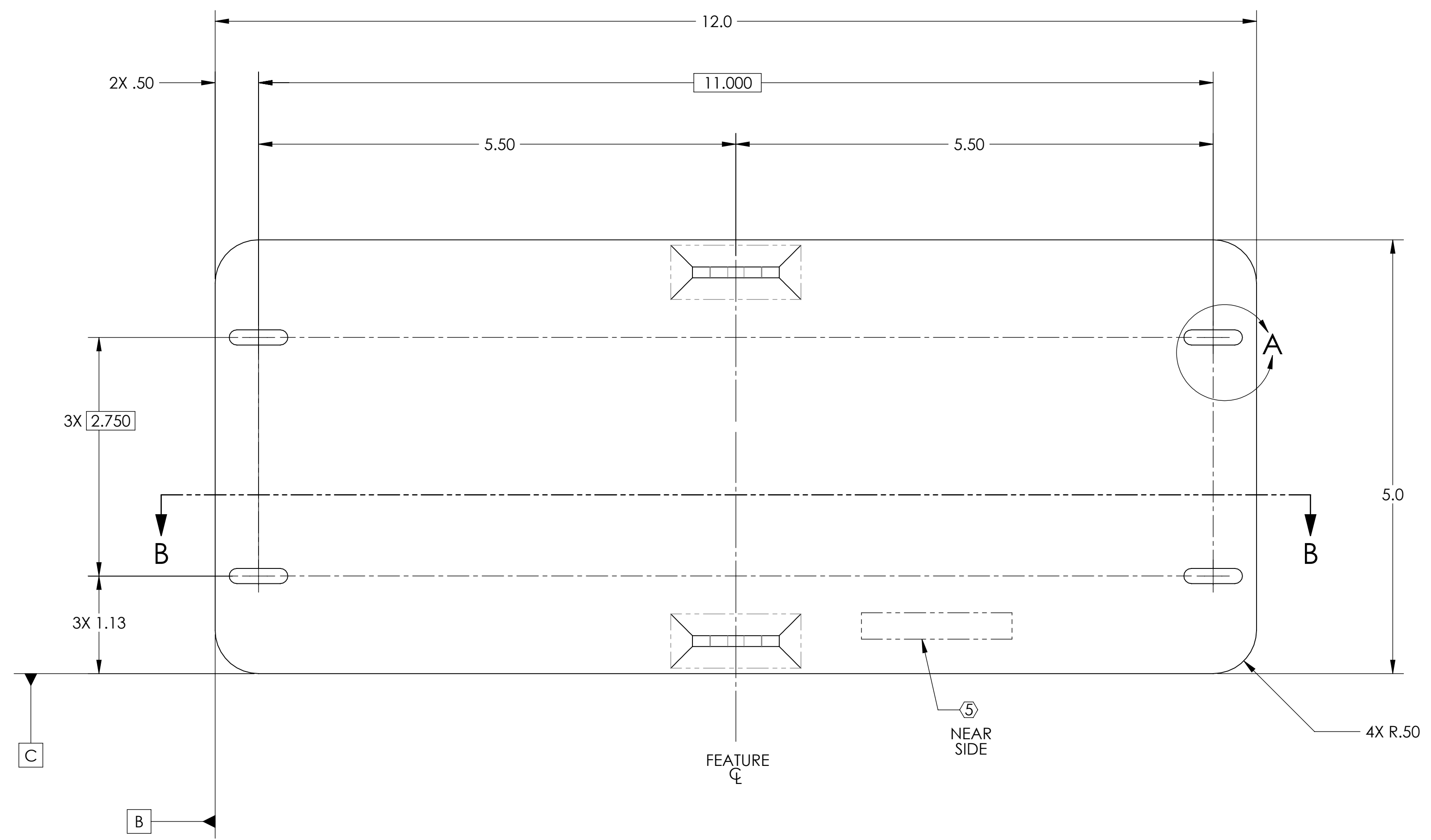
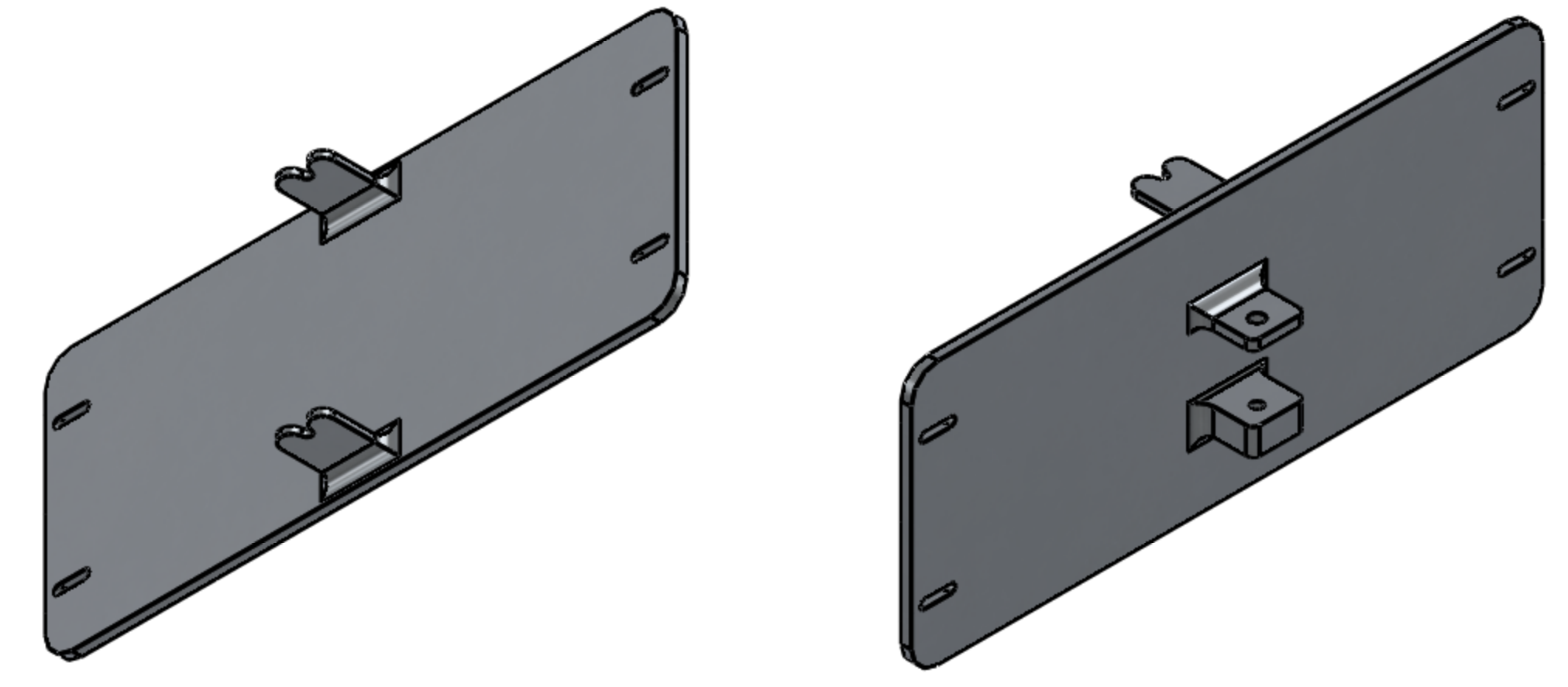
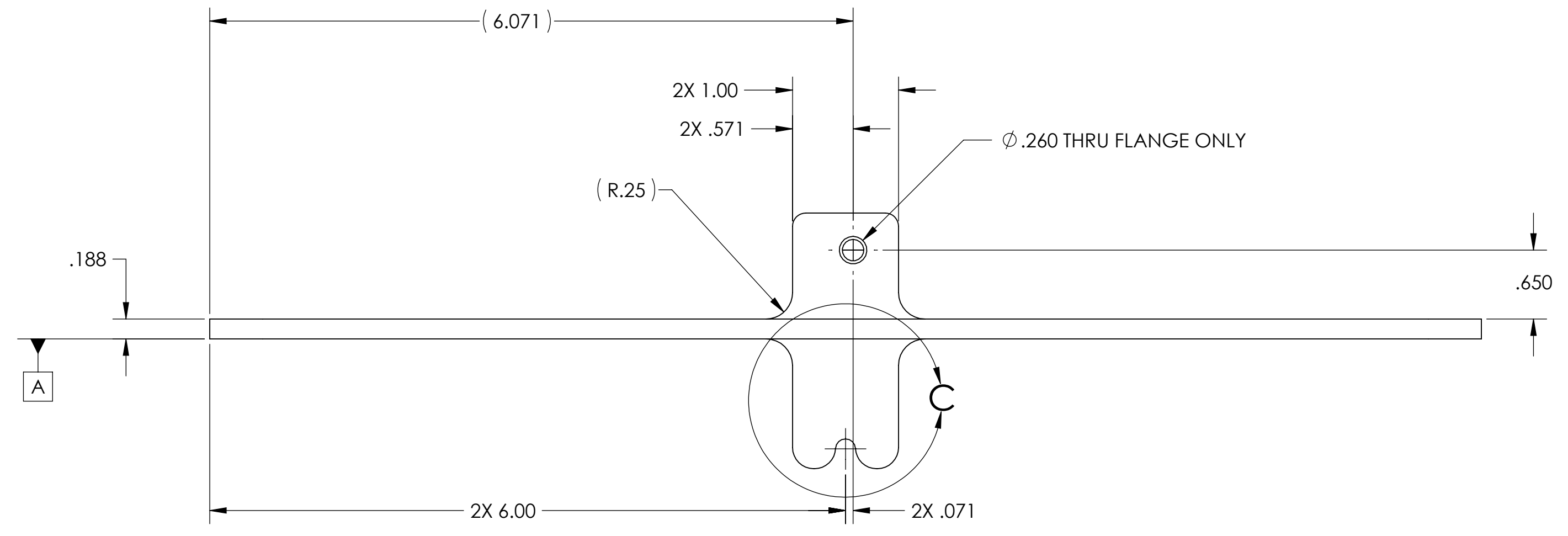

REV.	DATE	DCN #	DRAWING TREE #
v1	8-AUG-2010	-	-
v2	23-DEC-2010	E1000883-v1	E1000884-v1
-	-	-	-

NOTES AND TOLERANCES: (UNLESS OTHERWISE SPECIFIED)	
1. INTERPRET DRAWING PER ASME Y14.5-1994.	
2. REMOVE ALL SHARP EDGES, .02 MIN.	
3. DO NOT SCALE FROM DRAWING.	
4. ALL MACHINING FLUIDS MUST BE FULLY SYNTHETIC, FULLY WATER SOLUBLE AND FREE OF SULFUR, SILICONE, AND CHLORINE.	
DIMENSIONS ARE IN INCHES	
TOLERANCES:	
.XX ± .01	
.XXX ± .005	
ANGULAR ± 0.5°	
MATERIAL	6061-T6 (SS)
FINISH	63 μinch

LIGO CALIFORNIA INSTITUTE OF TECHNOLOGY
 MASSACHUSETTS INSTITUTE OF TECHNOLOGY

SYSTEM: ADVANCED LIGO SUB-SYSTEM: AOS

NEXT ASSY: D1001742, D1002431

PART NAME				EL FINE ADJUST PIVOT PLATE	
DESIGNER	M. JACOBSON	08 JUL 2010	SIZE	DWG. NO.	REV.
DRAFTER	A. COLE	8-AUG-2010	D	D1002311	v2
CHECKER	B. ANDERSON	05 JAN 2011	SCALE: 1:1	PROJECTION:	SHEET 1 OF 2
APPROVAL	C. TORRIE	06 JAN 2011			

D1002311_L1_CS_UHP_EL_FINE_ADJUST_PIVOT_PLATE_PDM_REV_K017_DRAWING_PDM_REV_K024

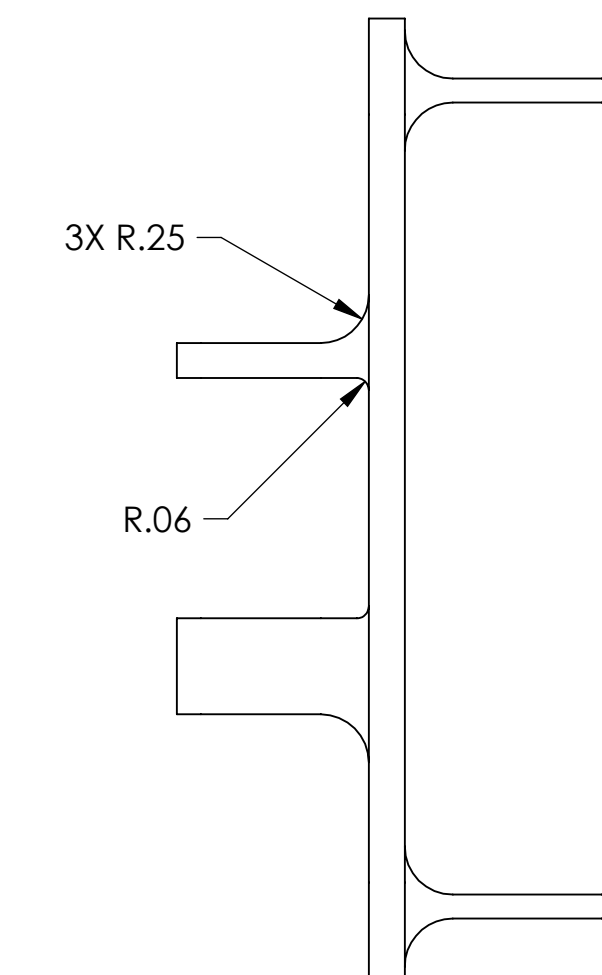
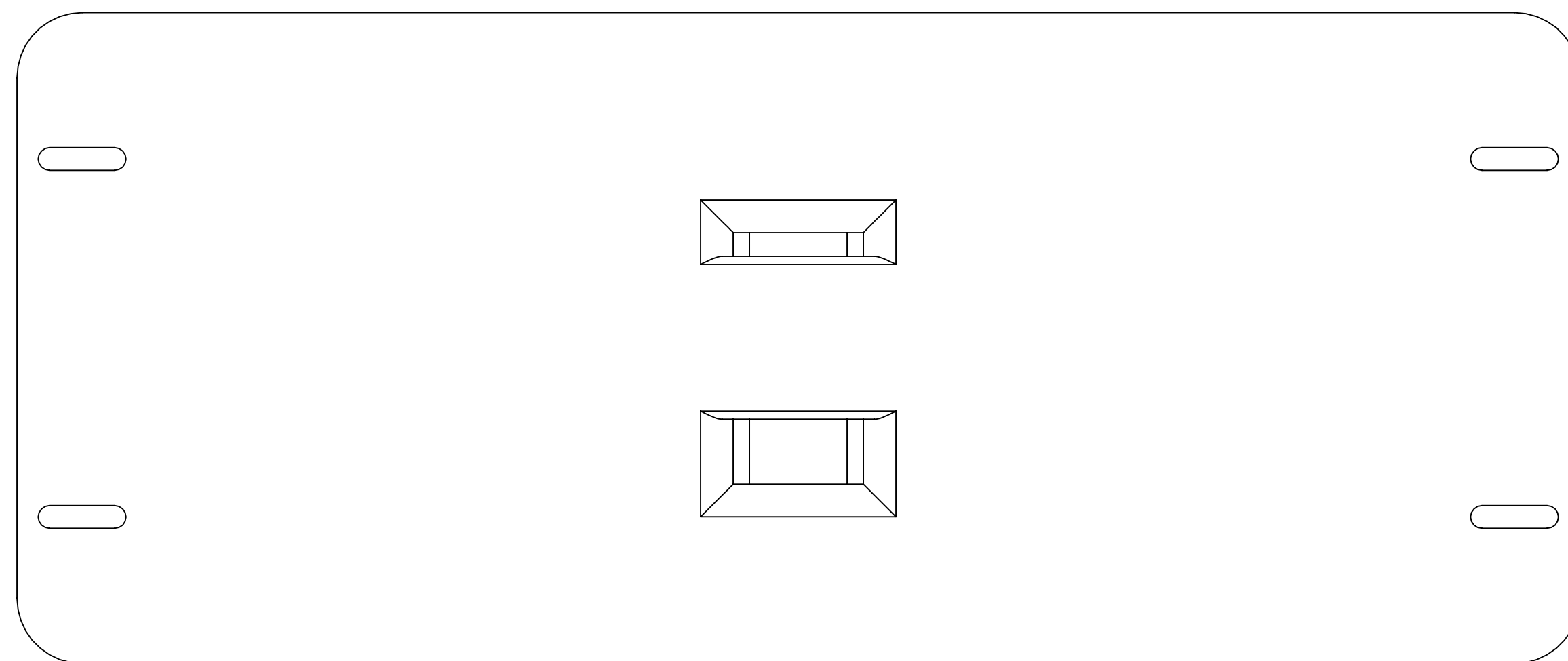
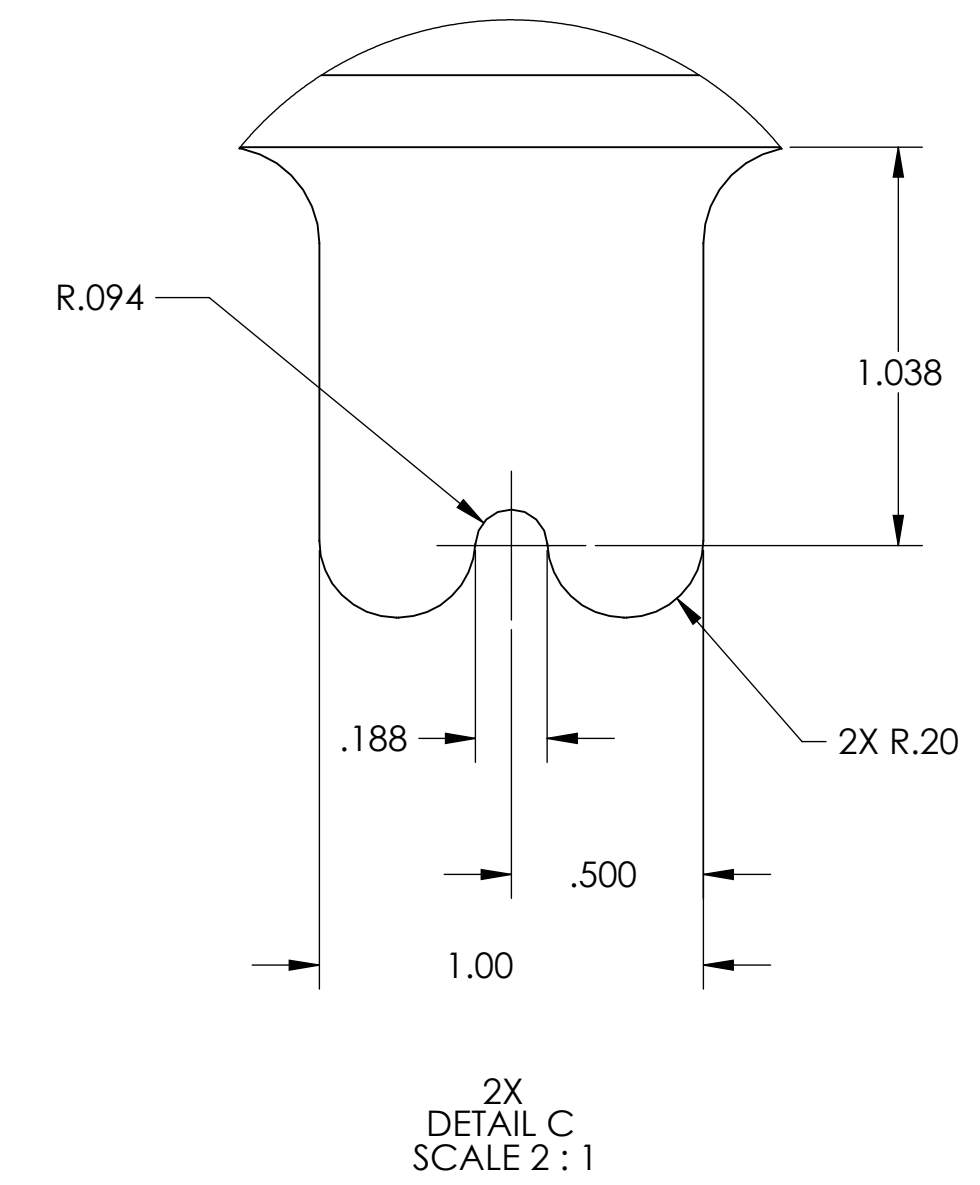
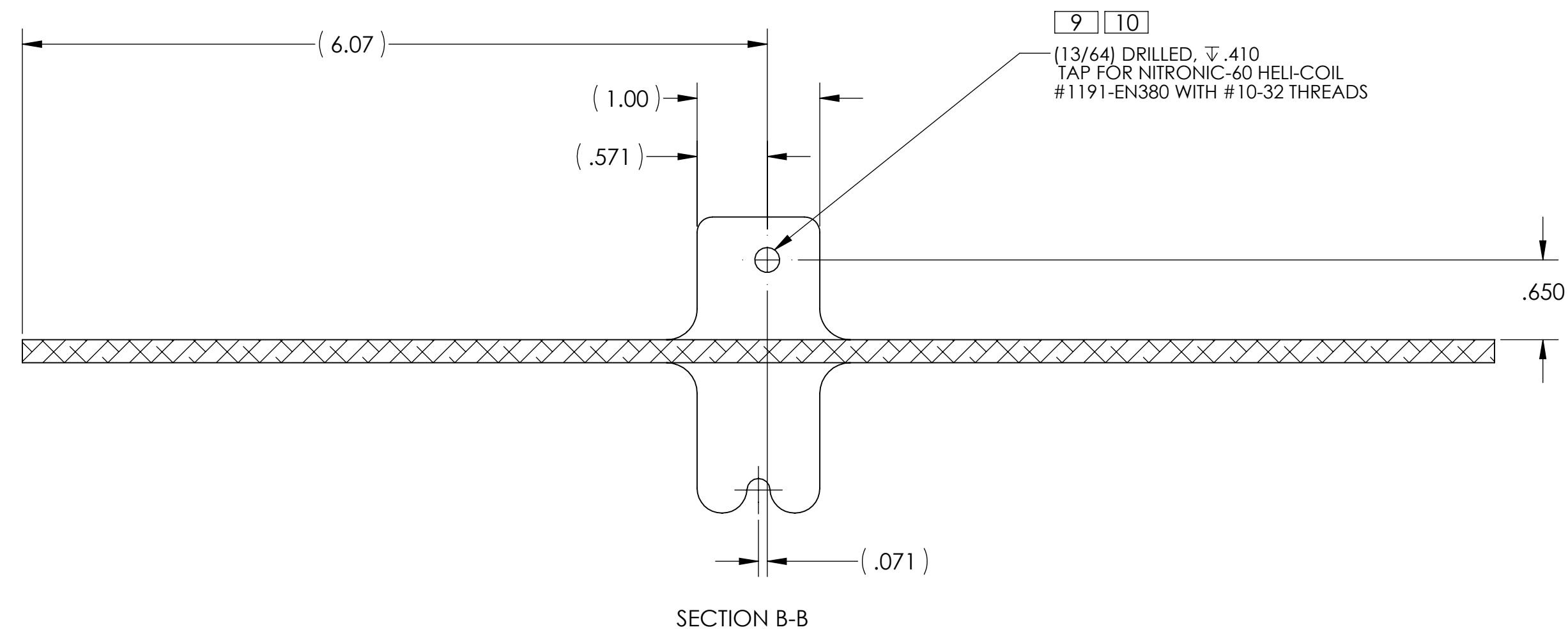
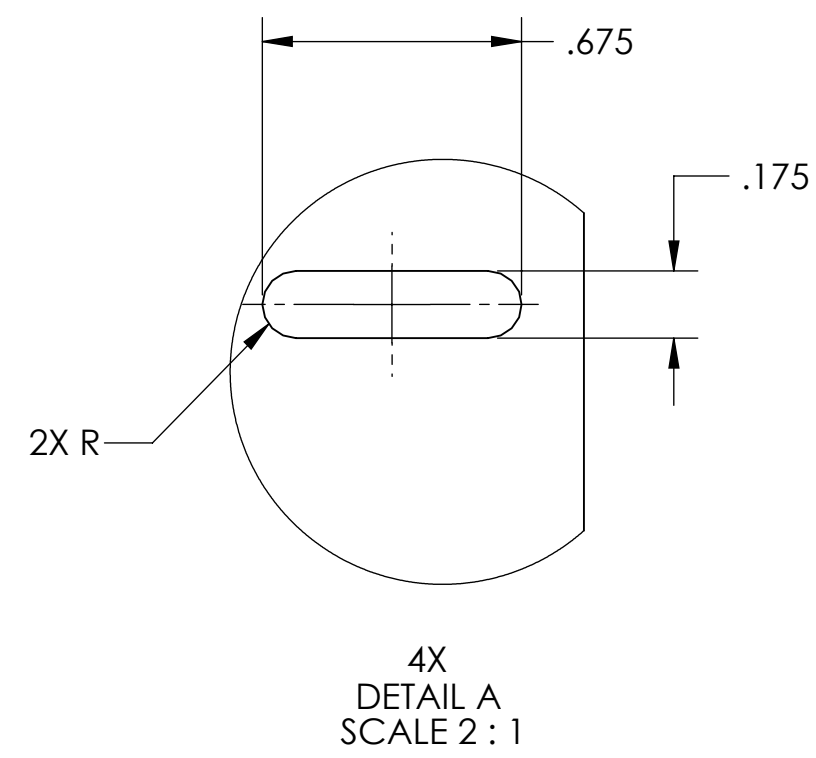

LIGO CALIFORNIA INSTITUTE OF TECHNOLOGY MASSACHUSETTS INSTITUTE OF TECHNOLOGY	
SIZE DWG. NO.	REV.
D D1002311	v2
SCALE: 1:1	PROJECTION: SHEET 2 OF 2

D:\002311\1_CS\UHV\EL\FINE ADJUST PIVOT PLATE.PART PDM REV: X017.DRAWING PDM REV: X024