

D1002304 DOWEL INSTALLATION PUNCH, .38 DIA. aLIGO BSC ISI, PART PDM REV: X-001, DRAWING PDM REV: X-002

NOTES CONTINUED:
 5. SCRIBE, ENGRAVE, OR MECHANICALLY STAMP (NO INKS OR DYES) DRAWING PART NUMBER, REVISION (AND VARIANT OR "TYPE" IF APPLICABLE ON NOTED SURFACE OF PART FOLLOWED ON THE NEXT LINE WITH A THREE DIGIT SERIAL NUMBER. SERIAL NUMBERS START AT 001 FOR THE FIRST ARTICLE AND PROCEED CONSECUTIVELY. USE MINIMUM 0.12 HIGH CHARACTERS, UNLESS THE SIZE OF THE PART DICTATES SMALLER CHARACTERS. A VIBRATORY TOOL MAY BE USED. EXAMPLE DXXXXXX-VY, TYPE-XX, S/N XXX.
 6. APPROXIMATE WEIGHT = 0.135 LB.
 7. MACHINE ALL SURFACES TO REMOVE OXIDES AND MILL FINISH. USE OF ABRASIVE REMOVAL TECHNIQUES (INCLUDING SANDING OR SCOURING FOR MATTE FINISH) IS NOT ALLOWED.
 8. ALL PARTS SHALL BE MANUFACTURED IN ACCORDANCE WITH LIGO SPECIFICATION E0900364.

REV.	DATE	DCN #	DRAWING TREE #
v1	30 Aug 2010	E1000373	-
v2	08 Nov. 2010	E1000685	-

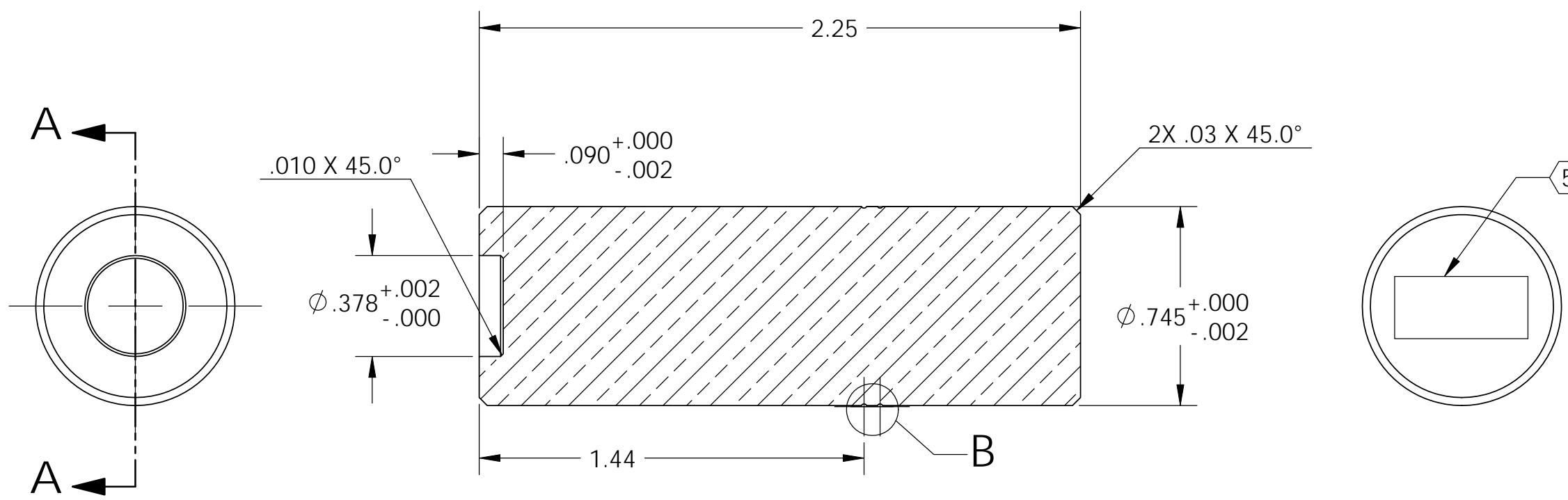

SECTION A-A

DETAIL B
SCALE 8 : 1

.02 X .02 AROUND
SHAFT SQ. OR ROUND
VENDOR OPTION

NOTES AND TOLERANCES: (UNLESS OTHERWISE SPECIFIED)				LIGO CALIFORNIA INSTITUTE OF TECHNOLOGY MASSACHUSETTS INSTITUTE OF TECHNOLOGY		PART NAME						
DIMENSIONS ARE IN INCHES		1. INTERPRET DRAWING PER ASME Y14.5-1994. 2. REMOVE ALL SHARP EDGES, R.02 MIN. 3. DO NOT SCALE FROM DRAWING. 4. ALL MACHINING FLUIDS MUST BE FULLY SYNTHETIC, FULLY WATER SOLUBLE AND FREE OF SULFUR, SILICONE, AND CHLORINE.		SYSTEM ADVANCED LIGO		SUB-SYSTEM SEI		DOWEL INSTALLATION PUNCH, 3/8 DIA, aLIGO BSC ISI				
TOLERANCES: .XX ± .015 .XXX ± .005		MATERIAL Brass		FINISH 32 μinch		NEXT ASSY		DESIGNER M.HILLARD	27 Aug 2010	SIZE B	DWG. NO. D1002304	REV. v2
ANGULAR ± .5°						CHECKER M.MATICHARD		30 Aug 2010	SCALE: 2:1	PROJECTION:	SHEET 1 OF 1	

8 7 6 5 4 3 2 1

D C B A

D C B A

8 7 6 5 4 3 2 1