

REV.	DATE	DCN #	DRAWING TREE #
v1	13 APR 2010	E1100356-x0	-
-	-	-	-
-	-	-	-

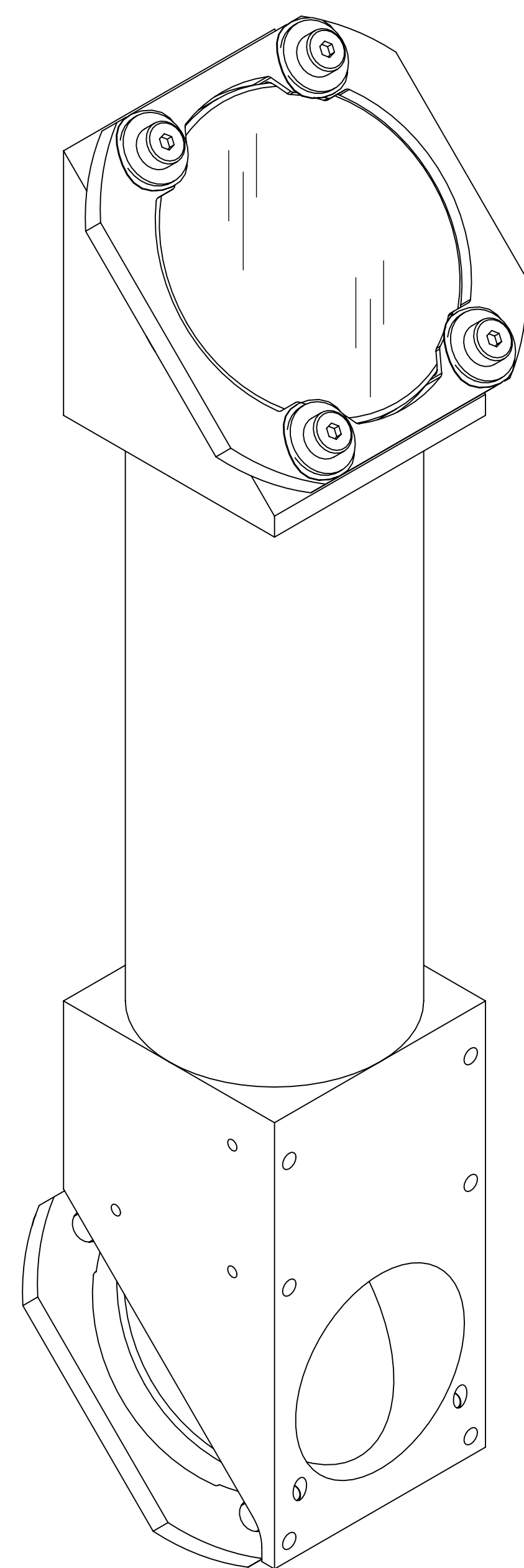

VIEW
SCALE 1:1
(BASIC SHOWN)

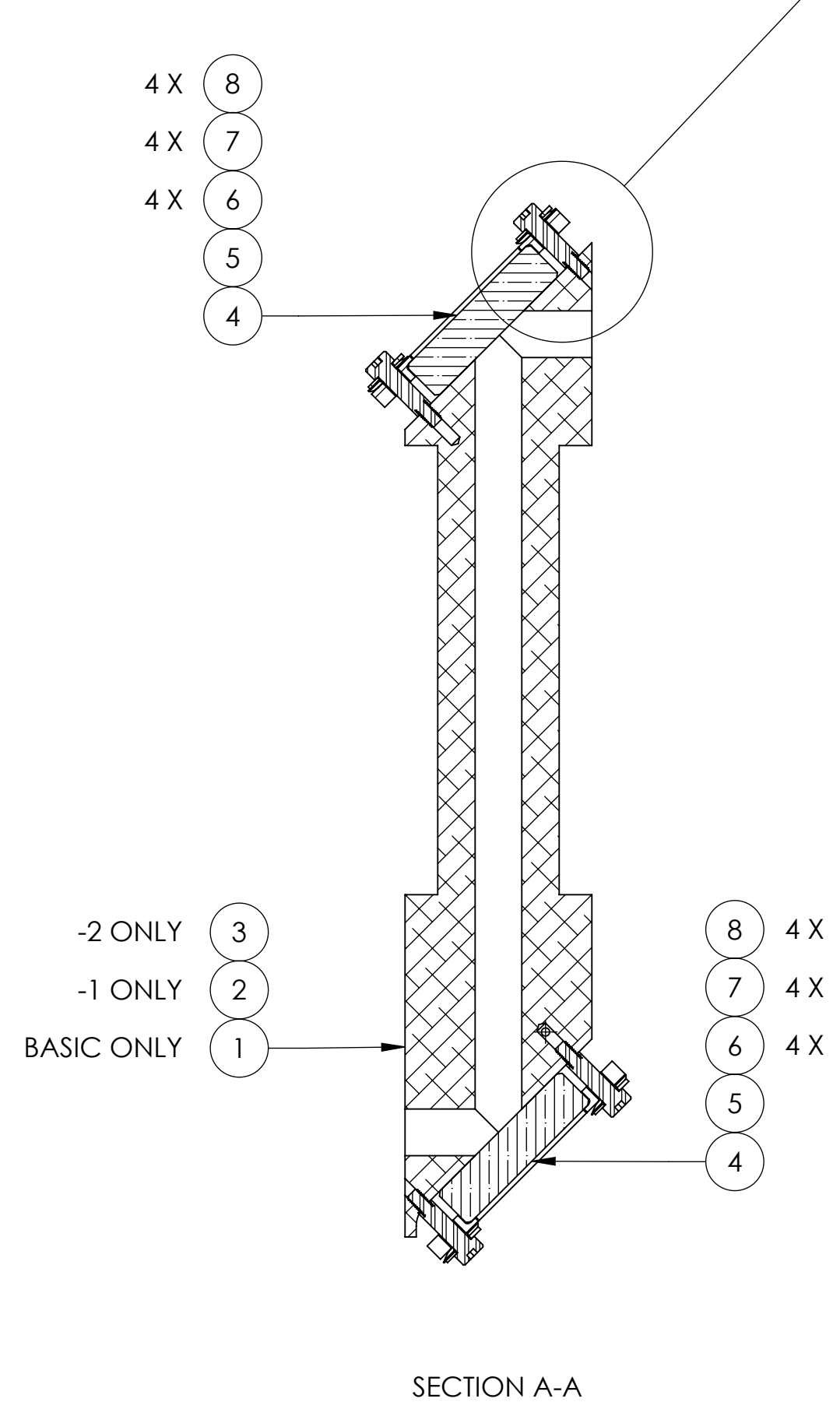

SECTION A-A

DETAIL E
SCALE 2:1

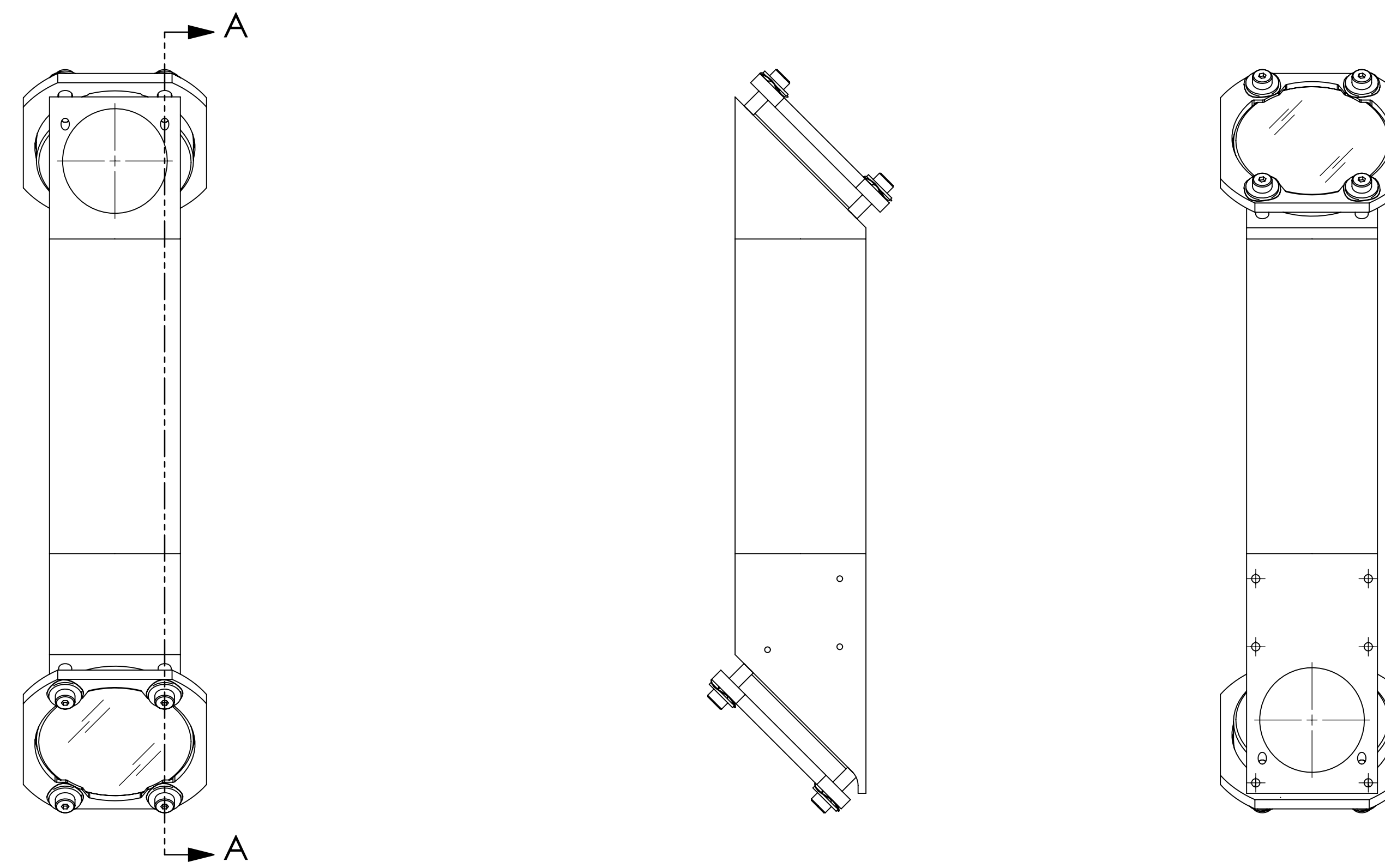

ITEM NO.	PART NUMBER	DESCRIPTION	MATERIAL	D1002260-2/QTY.	D1002260-1/QTY.	D1002260/QTY.
8	MS51576-22	SCREW, SHC, 10-32, .25 DIA. X .75 LG.	18-8 SSSL	8	8	8
7	MS15795-810	WASHER, FLAT, 1/4"	300 SERIES SSSL	8	8	8
6	92161A029	WASHER, WAVE, .31 I.D X .7 O.D	18-8 SSSL	8	8	8
5	D1002264	ALIGO, OPLEV, PERISCOPE, RING, MIRROR RETAINING	ALSI 304	2	2	2
4	NEWPORT #30D20BD.1	MIRROR, 3.00 O.D X .58 THK.	Glass	2	2	2
3	D1002259-2	ALIGO, OPLEV PERISCOPE OPTICAL BOX, BSC7-H2, BSC8-H2	6061-T6 (SS)	1	-	-
2	D1002259-1	ALIGO, OPLEV PERISCOPE OPTICAL BOX, BSC4-H2	6061-T6 (SS)	-	1	-
1	D1002259	ALIGO, OPLEV PERISCOPE OPTICAL BOX, BSC2-L1, H1	6061-T6 (SS)	-	-	1

PARTS LIST

PART NAME
ALIGO, OPLEV, PERISCOPE, OPTICAL BOX ASSY.

DIMENSIONS ARE IN INCHES

TOLERANCES:
.XX ± .01
.XXX ± .005

ANGULAR ± 1.0°

NOTES AND TOLERANCES: (UNLESS OTHERWISE SPECIFIED)

MATERIAL N/A FINISH N/A μinch NEXT ASSY D1100625



SYSTEM ADVANCED LIGO SUB-SYSTEM OPLEV

DESIGNER	C.WILKERSON	22 FEB 2011	SIZE	DWG. NO.	REV.
DRAFTER	Esanchez	12 APR 2011	D	D1002260	v1
CHECKER	J.LEWIS	10 MAY 2011	SCALE: 1:2	PROJECTION:	SHEET 1 OF 1
APPROVAL					