

**NOTES CONTINUED:**  
 5. SCRIBE, ENGRAVE, OR MECHANICALLY STAMP (NO INKS OR DYES) DRAWING PART NUMBER, REVISION (AND VARIANT OR "TYPE" IF APPLICABLE) ON NOTED SURFACE OF PART FOLLOWED ON THE NEXT LINE WITH A THREE DIGIT SERIAL NUMBER. SERIAL NUMBERS START AT 001 FOR THE FIRST ARTICLE AND PROCEED CONSECUTIVELY. USE MINIMUM 0.12" HIGH CHARACTERS, UNLESS THE SIZE OF THE PART DICTATES SMALLER CHARACTERS. A VIBRATORY TOOL MAY BE USED.  
 EXAMPLE: DXXXXXX-VY, TYPE-XX, S/N XXX

6. MACHINE ALL SURFACES TO REMOVE OXIDES AND MILL FINISH, USE OF ABRASIVE REMOVAL TECHNIQUES IS NOT ALLOWED.

7. ALL PARTS SHALL BE MANUFACTURED IN ACCORDANCE WITH LIGO SPECIFICATION E0900364.

REV.	DATE	DCN #	DRAWING TREE #
v1	08 OCT 2010	E1000563	
v2	28 FEB 2011	E1000563	
v3	29 DEC 2011	E1000563	

D1002257\_ALIGO\_AOS\_D100256\_Crossbar Plate\_In, PART PDM REV: X-007, DRAWING PDM REV: X-015

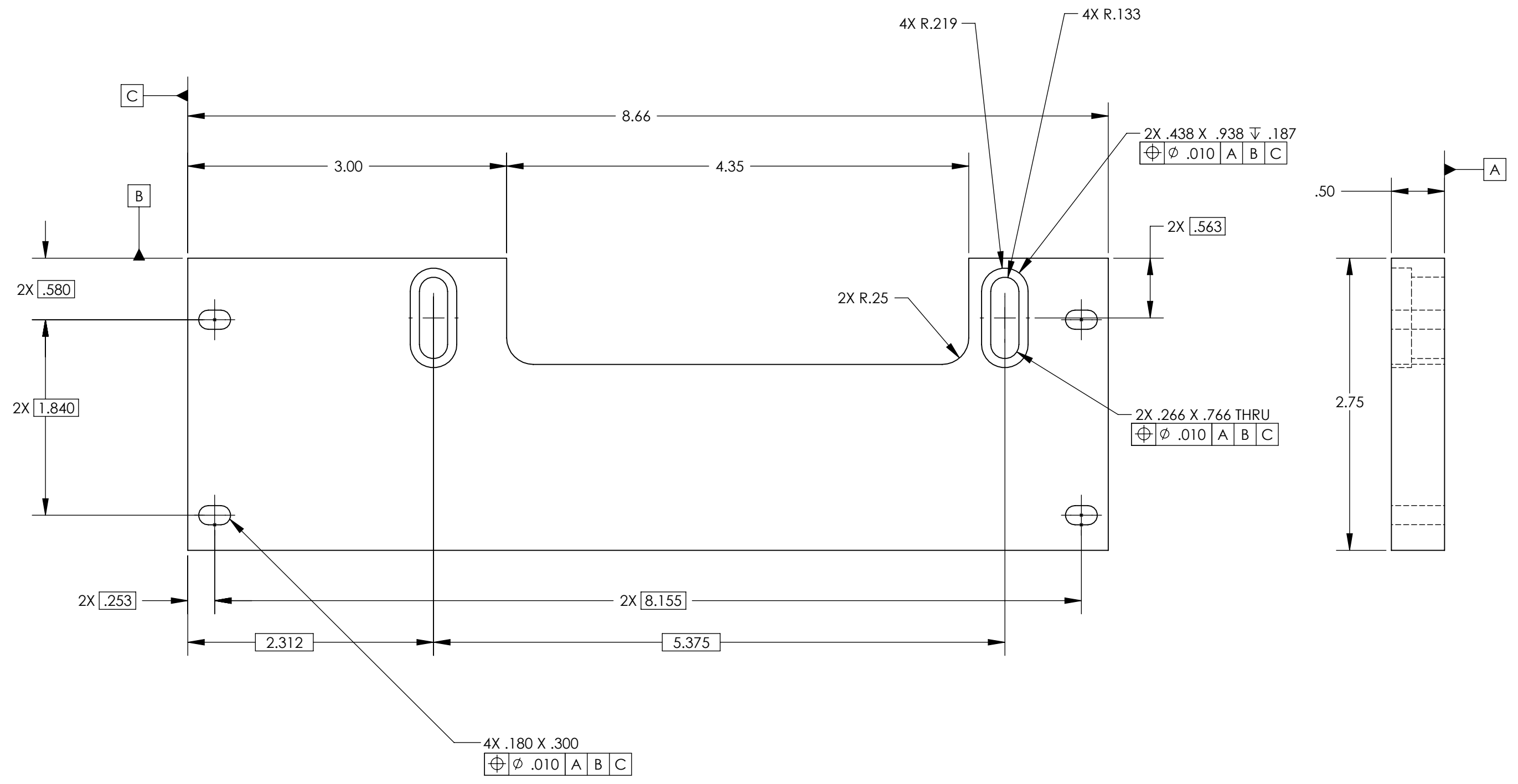

NOTES AND TOLERANCES: (UNLESS OTHERWISE SPECIFIED)				LIGO CALIFORNIA INSTITUTE OF TECHNOLOGY MASSACHUSETTS INSTITUTE OF TECHNOLOGY		PART NAME	
DIMENSIONS ARE IN TOLERANCES: .XX ± .02 .XXX ± .010 ANGULAR ± .5°				1. INTERPRET DRAWING PER ASME Y14.5-1994. 2. REMOVE ALL SHARP EDGES, R.02 MIN. 3. DO NOT SCALE FROM DRAWING. 4. ALL MACHINING FLUIDS MUST BE FULLY SYNTHETIC, FULLY WATER SOLUBLE AND FREE OF SULFUR, SILICONE, AND CHLORINE.		<b>CROSSBAR PLATE_IN</b>	
MATERIAL 6061-T6 Al		FINISH 63 μinch		SYSTEM ADVANCED LIGO SUB-SYSTEM AOS		DESIGNER DRAFTER MRUIZ CHECKER APPROVAL	
NEXT ASSY D1002256		SIZE DWG. NO. B		DWG. NO. D1002257		REV. v3	
				SCALE: 1:1		PROJECTION:	
				SHEET 1 OF 1			