

4

3

2

1

NOTES CONTINUED:

- 5. SCRIBE, ENGRAVE, OR MECHANICALLY STAMP (NO INKS OR DYES) DRAWING PART NUMBER, REVISION (AND VARIANT OR "TYPE" IF APPLICABLE) ON NOTED SURFACE OF PART FOLLOWED ON THE NEXT LINE WITH A THREE DIGIT SERIAL NUMBER. SERIAL NUMBERS START AT 001 FOR THE FIRST ARTICLE AND PROCEED CONSECUTIVELY. USE MINIMUM 0.12" HIGH CHARACTERS, UNLESS THE SIZE OF THE PART DICTATES SMALLER CHARACTERS. A VIBRATORY TOOL MAY BE USED. EXAMPLE: DXXXXXX-VY, TYPE-XX, S/N XXX
- 6. MACHINE ALL SURFACES TO REMOVE OXIDES AND MILL FINISH. USE OF ABRASIVE REMOVAL TECHNIQUES IS NOT ALLOWED.
- 7. ALL PARTS SHALL BE MANUFACTURED IN ACCORDANCE WITH LIGO SPECIFICATION E0900364.

REV.	DATE	DCN #	DRAWING TREE #
v1	10 AUG 2010	E1000301	E080191
-	-	-	-
-	-	-	-

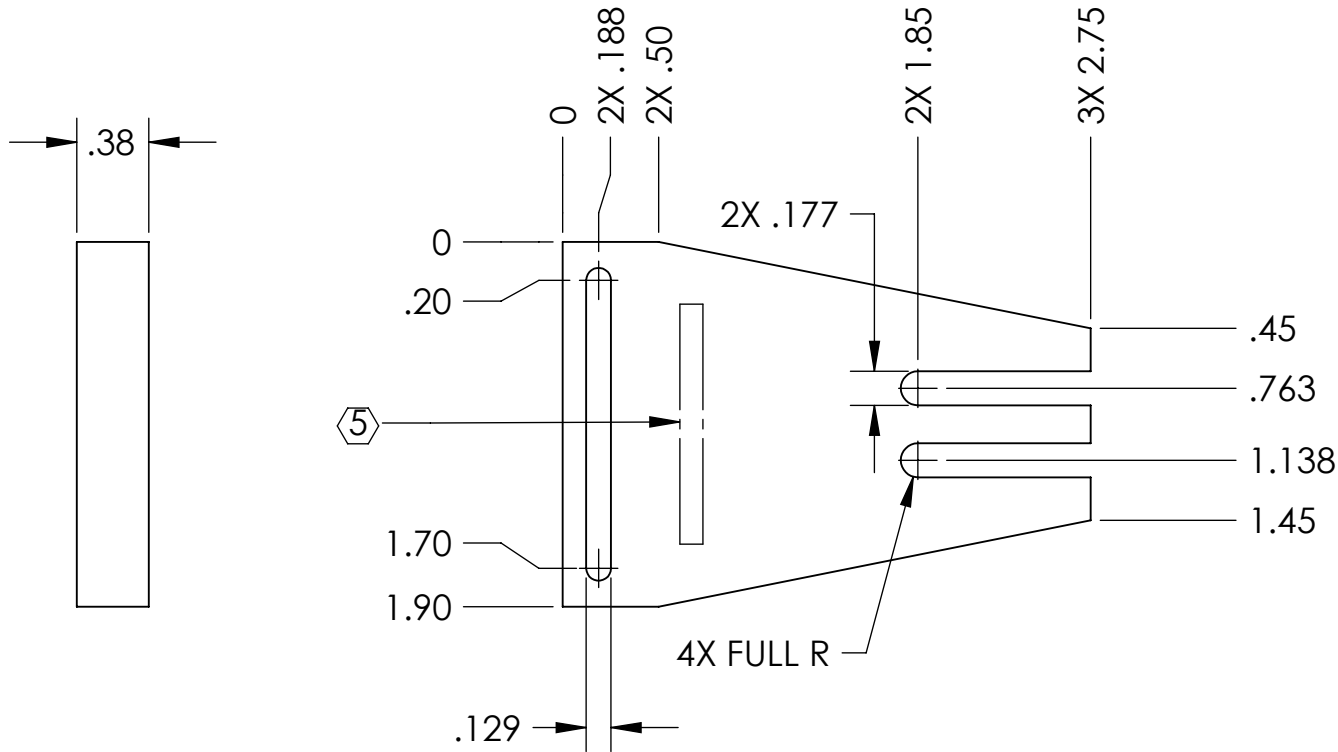
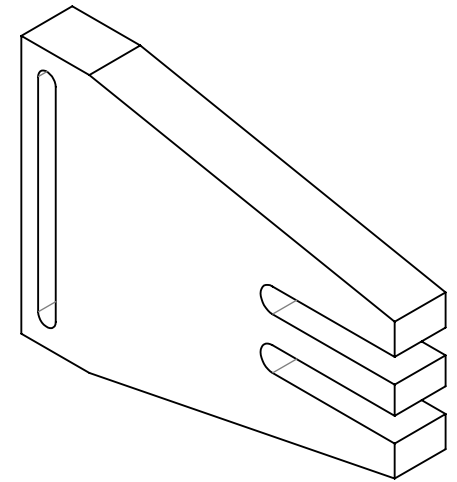

NOTES AND TOLERANCES: (UNLESS OTHERWISE SPECIFIED)

DIMENSIONS ARE IN INCHES

TOLERANCES:
.XX ± .01
.XXX ± .005

ANGULAR ± 0.5°

- 1. INTERPRET DRAWING PER ASME Y14.5-1994.
- 2. REMOVE ALL SHARP EDGES, R.02 MIN.
- 3. DO NOT SCALE FROM DRAWING.
- 4. ALL MACHINING FLUIDS MUST BE FULLY SYNTHETIC, FULLY WATER SOLUBLE AND FREE OF SULFUR, SILICONE, AND CHLORINE.

MATERIAL 6061-T6 Al
FINISH 32 μinch



SYSTEM ADVANCED LIGO SUB-SYSTEM SUS
NEXT ASSY MOUNTING BRACKET, COIL HOLDER

PART NAME MOUNTING BRACKET LONGITUDINAL SECTION

DESIGNER	D. BRIDGES	11 AUG 2010	SIZE	DWG. NO.	REV.
DRAFTER	D. BRIDGES	14 AUG 2010	A	D1002135	v1
CHECKER	B. MOORE	16 AUG 2010	SCALE: 1:1	PROJECTION:	SHEET 1 OF 1
APPROVAL					

4

3

2

1