

NOTES CONTINUED:

- 5. SCRIBE, ENGRAVE, OR MECHANICALLY STAMP (NO INKS OR DYES) DRAWING PART NUMBER, REVISION (AND VARIANT OR "TYPE" IF APPLICABLE) ON NOTED SURFACE OF PART FOLLOWED ON THE NEXT LINE WITH A THREE DIGIT SERIAL NUMBER. SERIAL NUMBERS START AT 001 FOR THE FIRST ARTICLE AND PROCEED CONSECUTIVELY. USE MINIMUM 0.12" HIGH CHARACTERS, UNLESS THE SIZE OF THE PART DICTATES SMALLER CHARACTERS. A VIBRATORY TOOL MAY BE USED. EXAMPLE: DXXXXXX-VY, TYPE-XX, S/N XXX
- 6. APPROXIMATE WEIGHT = 155 LB.
- 7. ALL PARTS SHALL BE MANUFACTURED IN ACCORDANCE WITH LIGO SPECIFICATION E0900364.
- 8. ALL TUBES AND SHEETS TO BE FREE OF DEFECTS, DINGS AND SCRATCHES AND HAVE A WORKMANLIKE FINISH. SURFACE IMPERFECTIONS SUCH AS HANDLING MARK, SHALLOW PITS AND SCRATCHES, ARE ACCEPTABLE PROVIDED THEY ARE WITHIN 10% OF SPECIFIED WALL OR .002" (0.05mm), WHICHEVER IS GREATER.
- 9. EACH TUBE SHOULD BE INDIVIDUALLY WRAPPED AND PROTECTED FROM SCRATCHES, PITTING AND DIGS DURING TRANSPORT AND HANDLING.
- 10. PRIOR TO WELDING, ALL PARTS MUST BE THOROUGHLY CLEANED TO REMOVE ALL OIL, GREASE, INK MARKINGS, DIRT AND CHIPS USING SOAP AND WATER OR SOLVENT (ACETONE).
- 11. WELDING: ALL DIMENSIONS APPLY AFTER WELDING. ALL WELDS SHALL BE DONE ON THE INTERIOR OF THE CONTAINER SUCH THAT NO SEAMS ARE EXPOSED ON THE INTERIOR OF THE BOX. ALL WELDS MUST BE CONTINUOUS. SEAMS WILL TRAP CONTAMINATION AND BE HARD TO CLEAN. ALL WELDS MUST BE COMPLETE JOINT PENETRATION WELDS OR PARTIAL PENETRATION WELDS. THE CONTAINER SHOULD FULLY SEAL AT THE WELDS, SUCH THAT THE CONTAINER IS AIR TIGHT. NO TRAPPED VOLUMES ARE PERMITTED. WELDMENTS WITH CREVICES ARE CONSIDERED NON-CLEANABLE SINCE THESE CREVICES ACT AS TRAPS FOR CLEANING SOLUTIONS. ALL WELDERS SHOULD BE CERTIFIED TO AMERICAN WELDING SOCIETY (AWS).
- 12. REGULAR FINISH ON ALUM WELDING IS ACCEPTABLE. THE INSIDE OF THE BOX IS MORE IMPORTANT THAN THE OUTSIDE. IF REMEDIAL ACTION IS REQUIRED TO REPAIR A WELD THEN CARBIDE BURRS ARE ALLOWED.

REV.	DATE	DCN #	DRAWING TREE #
V1	17 AUG 2010		
V2	20 AUG 2010		
V3	29 SEPT 2010		
V4	12 OCT 2010	E1000577	
V5	7 DEC 2010	E1000840	

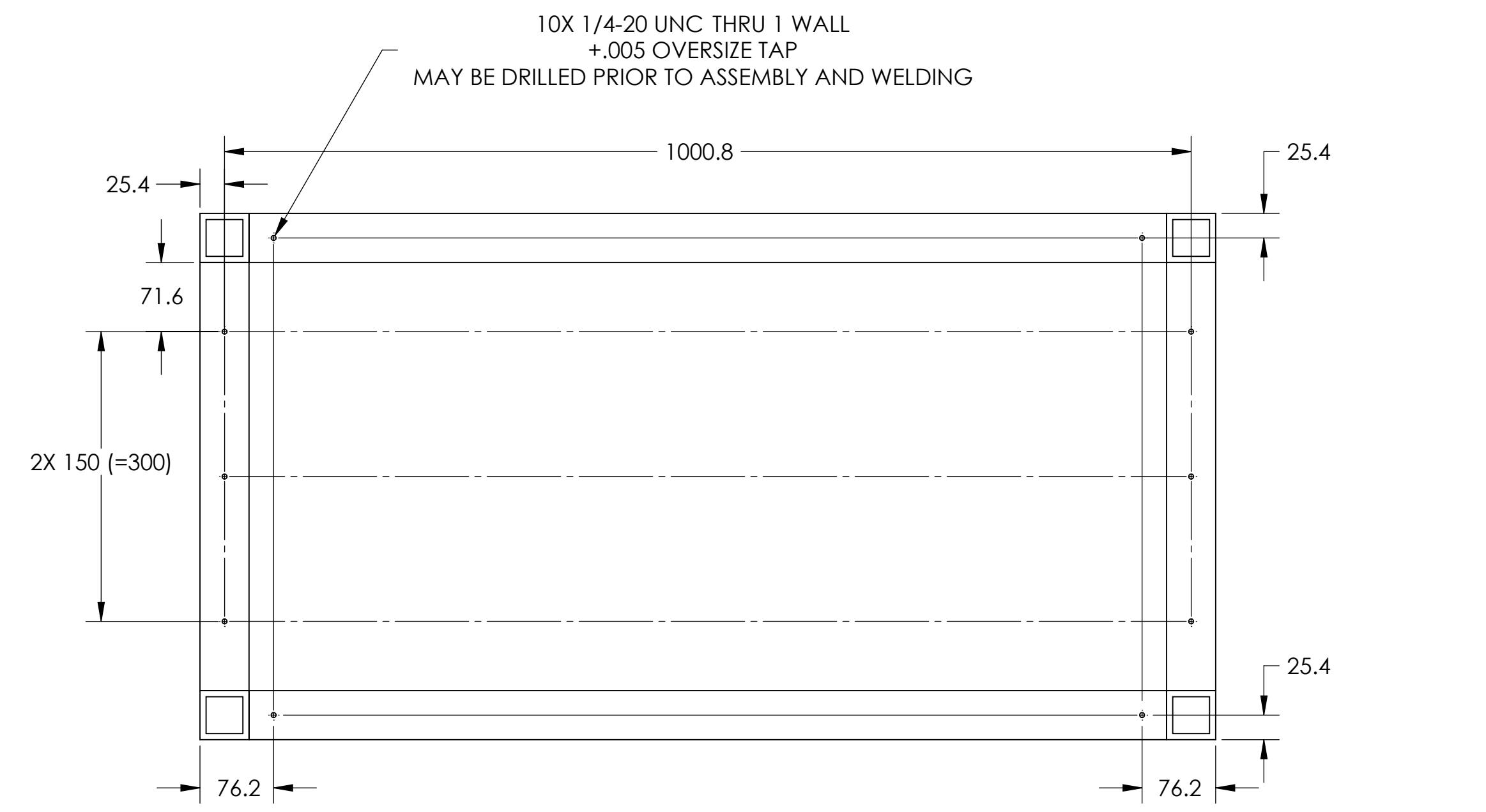
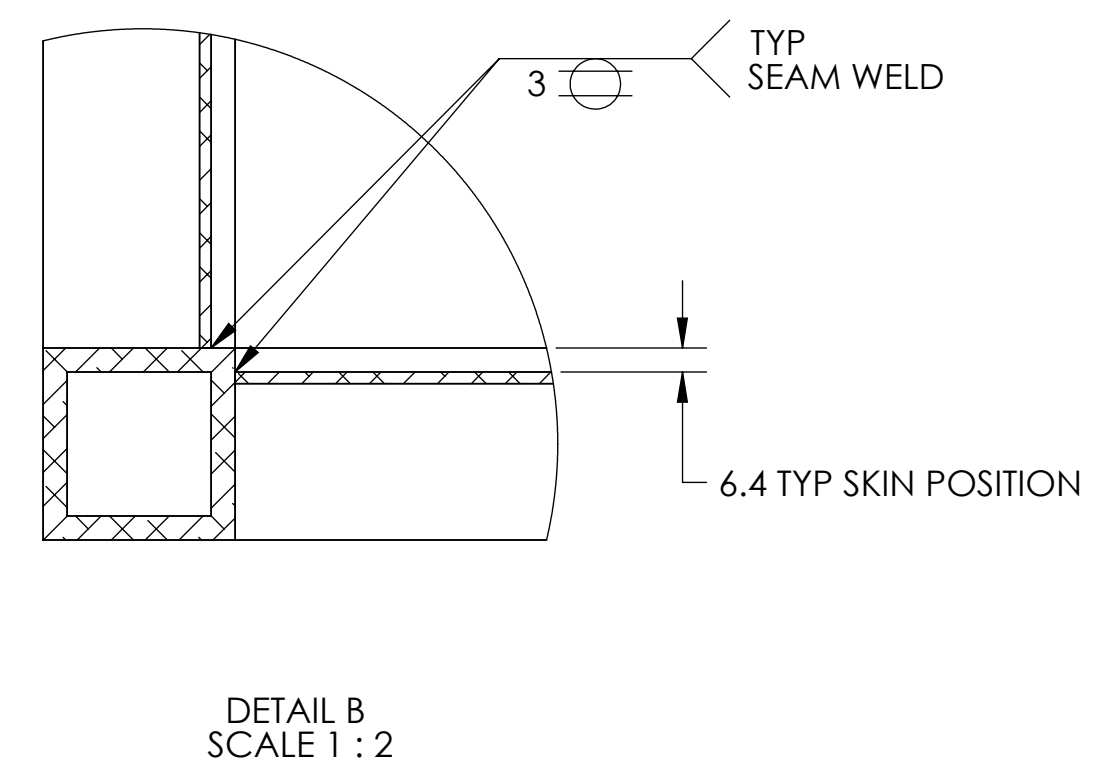
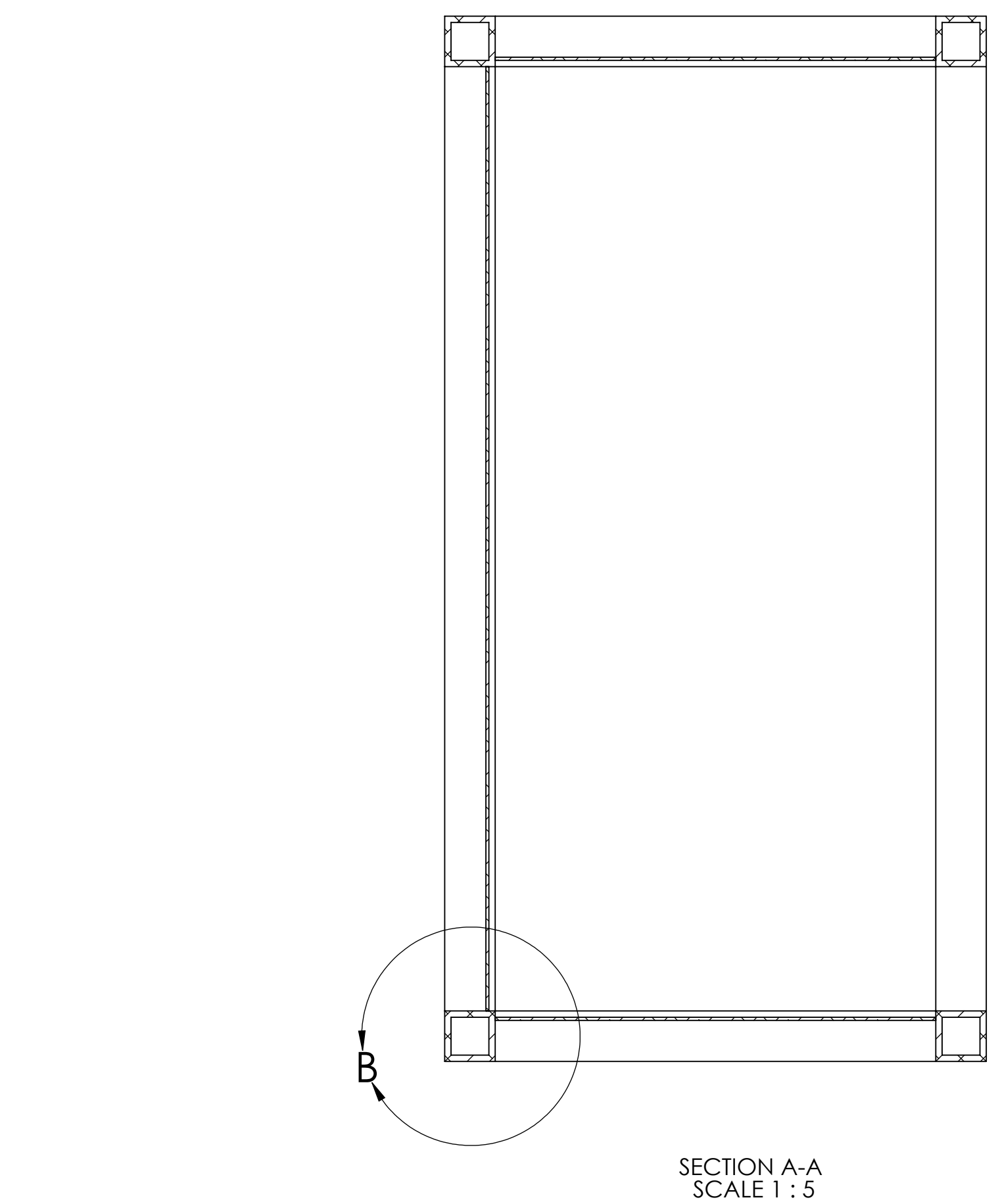
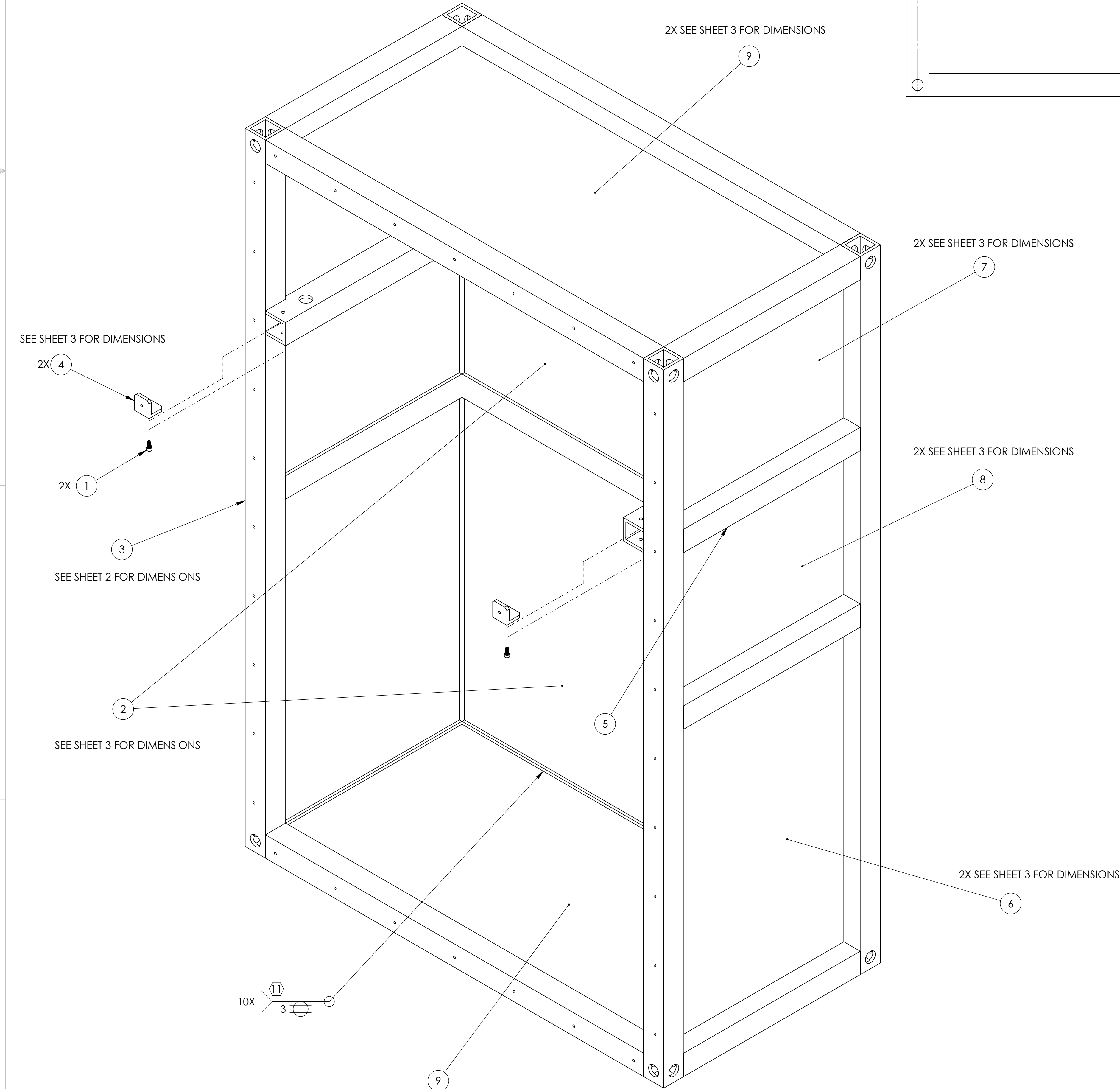
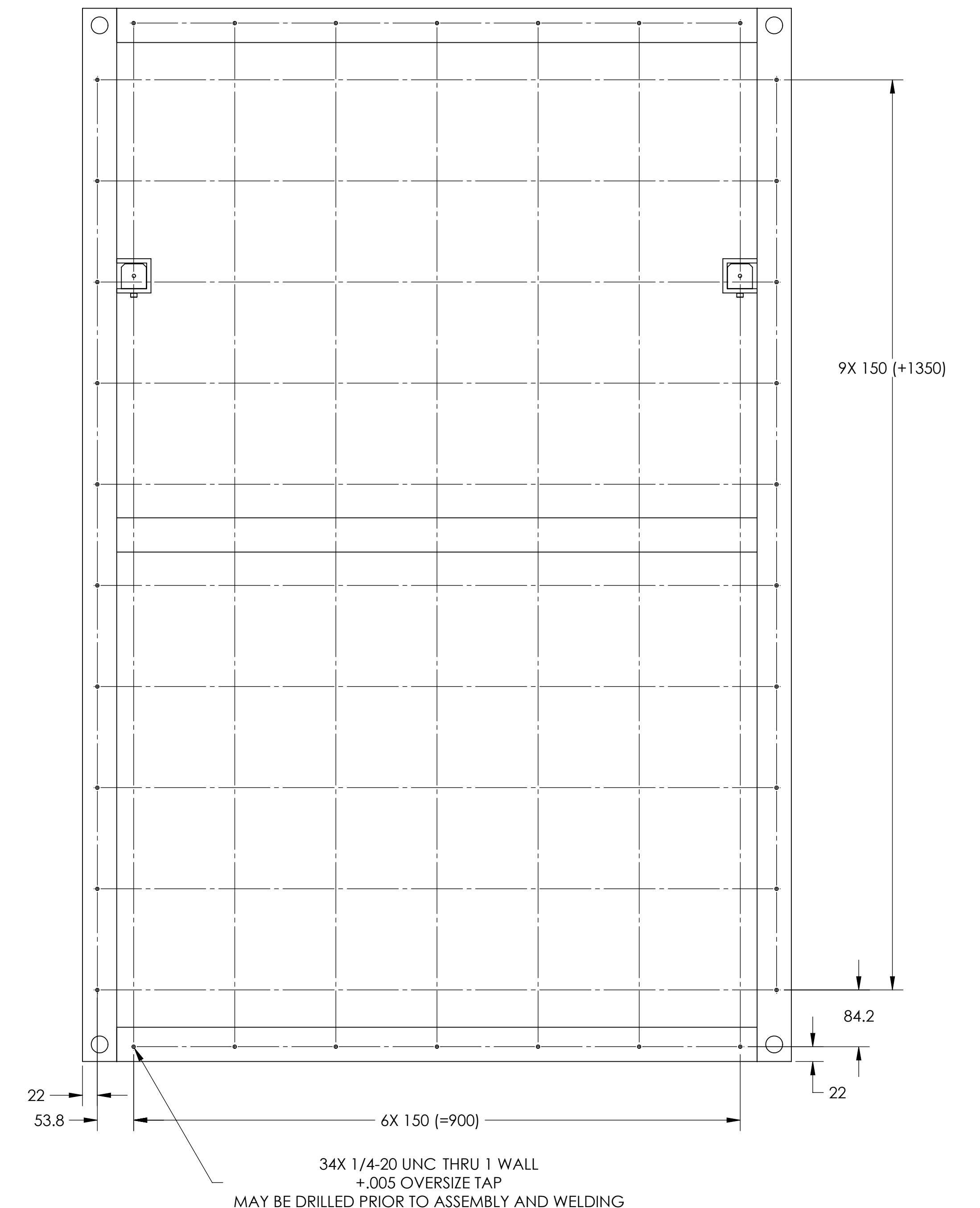
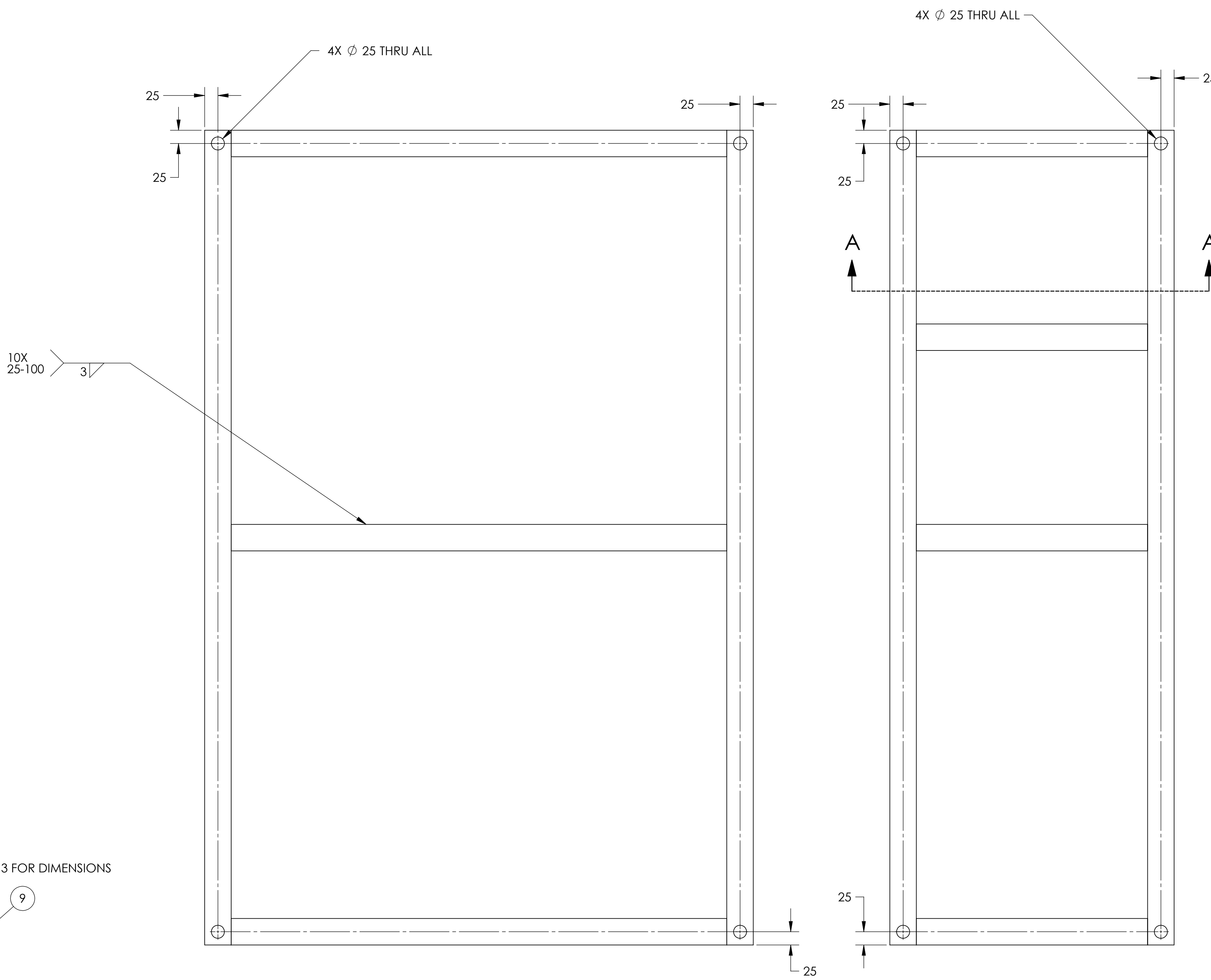

ITEM NO.	PART NUMBER	DESCRIPTION	MATERIAL	REQ	SPARE	TOTAL
9	6061-T6 Al	TOP AND BOTTOM SKIN	LOWER QUAD STORAGE CONTAINER TOP AND BOTTOM SKIN	2		2
8	6061-T6 Al	SIDE SKIN	MIDDLE SIDE SKIN	2		2
7	6061-T6 Al	SIDE SKIN	UPPER SIDE SKIN	2		2
6	6061-T6 Al	SIDE SKIN	LOWER SIDE SKIN	2		2
5	6061-T6 Al	LOWER STRUCTURE SHELF	LOWER QUAD STORAGE CONTAINER STRUCTURE SHELF	2		2
4	6061-T6 Al	END PLUG	END PLUG	2		2
3	6061-T6 Al	BASIC WELDMENT	LOWER QUAD STORAGE CONTAINER WELDMENT	1		1
2	6061-T6 Al	BACK SKIN	LOWER QUAD STORAGE CONTAINER BACK SKIN	2		2
1	92200AS37	SCREW, SHC, 1/4-20 x 1/2, MS16995-48, MC #92200AS37	300 S5TL	2		2

NOTES AND TOLERANCES: (UNLESS OTHERWISE SPECIFIED)

- INTERPRET DRAWING PER ASME Y14.5-1994.
- REMOVE ALL SHARP EDGES, R.02 MIN.
- DO NOT SCALE FROM DRAWING.
- ALL MACHINING FLUIDS MUST BE FULLY SYNTHETIC, FULLY WATER SOLUBLE AND FREE OF SULFUR, SILICONE, AND CHLORINE.

TOLERANCES:
 .XX ± .25
 .XXX ± .13
 ANGULAR ± .5°

MATERIAL: N/A
 FINISH: N/A μinch

DESIGNER: K. BUCKLAND
 DRAFTER: K. BUCKLAND
 CHECKER:
 APPROVAL:

SYSTEM: ADVANCED LIGO
 SUB-SYSTEM: SUS
 NEXT ASSY: D1002118

CALIFORNIA INSTITUTE OF TECHNOLOGY
 MASSACHUSETTS INSTITUTE OF TECHNOLOGY

PART NAME: LOWER STRUCTURE STORAGE CONTAINER WELDMENT

DATE: 2 AUG 2010
 SIZE: E
 DWG. NO.: D1002119
 SCALE: 1:4
 PROJECTION:

REV. V5
 SHEET 1 OF 3

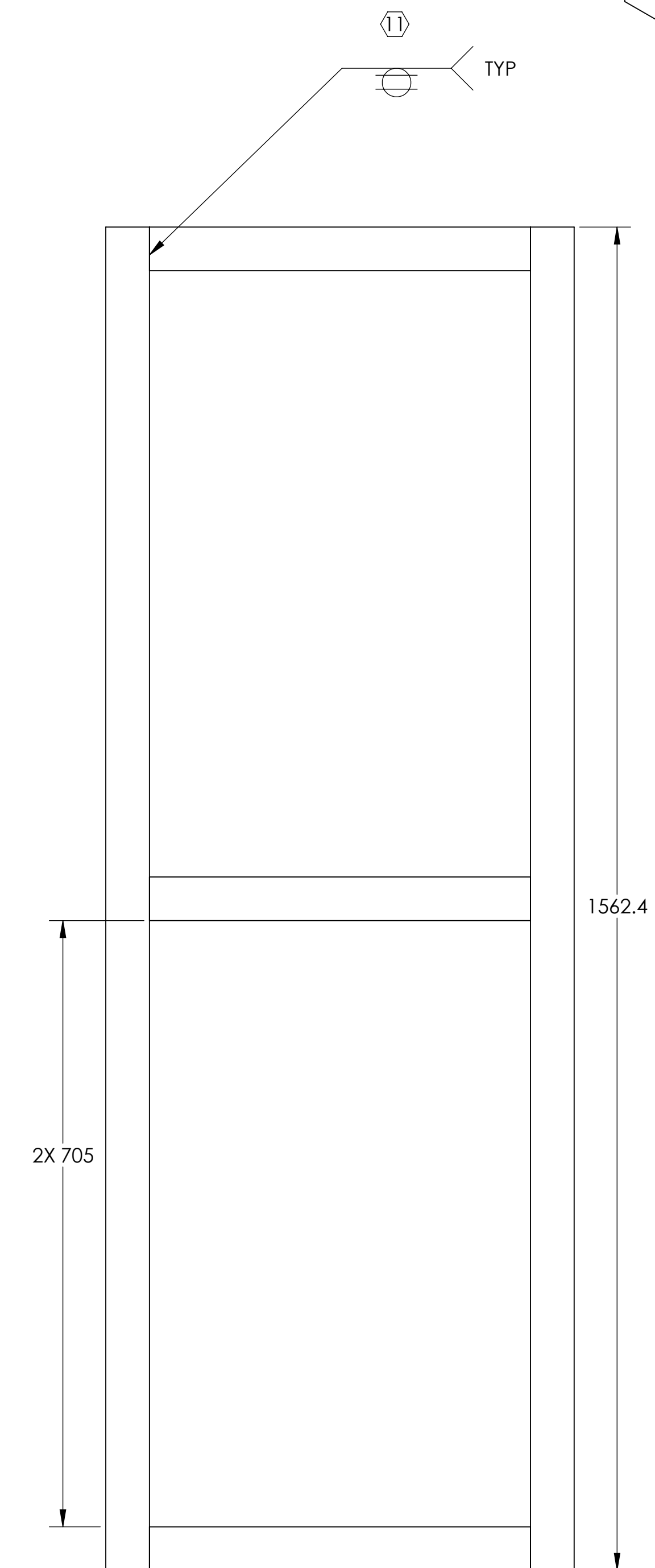
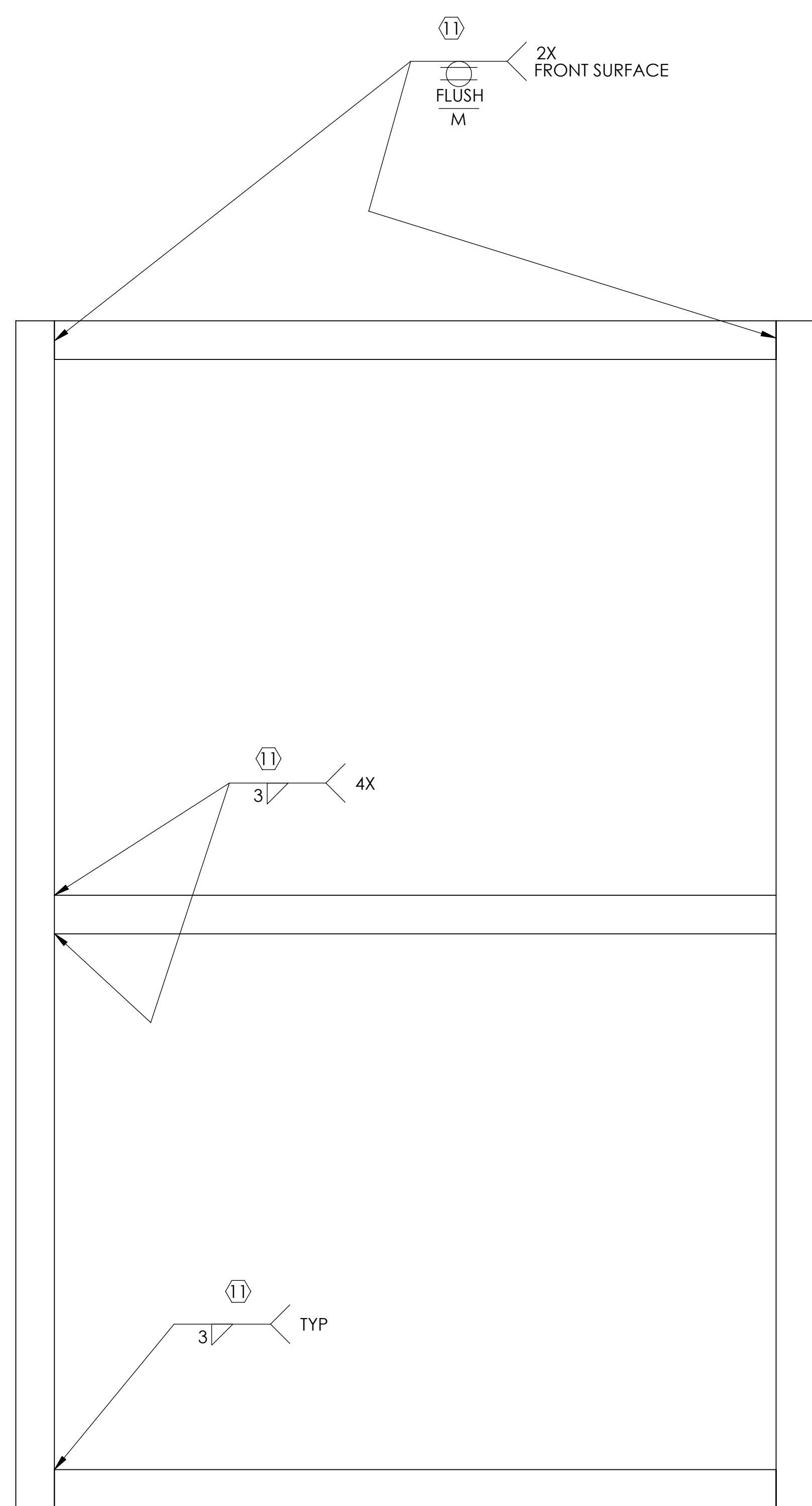
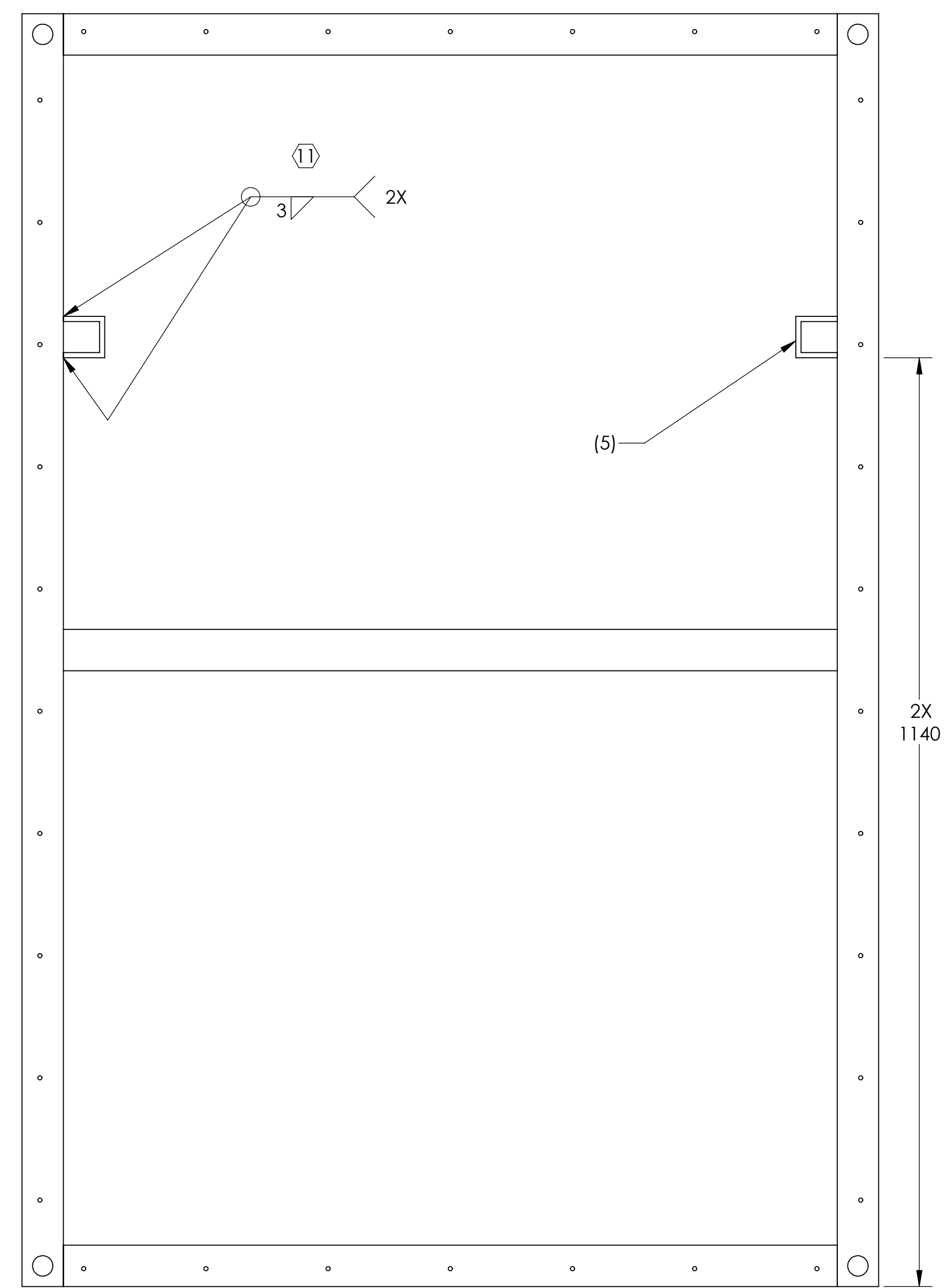
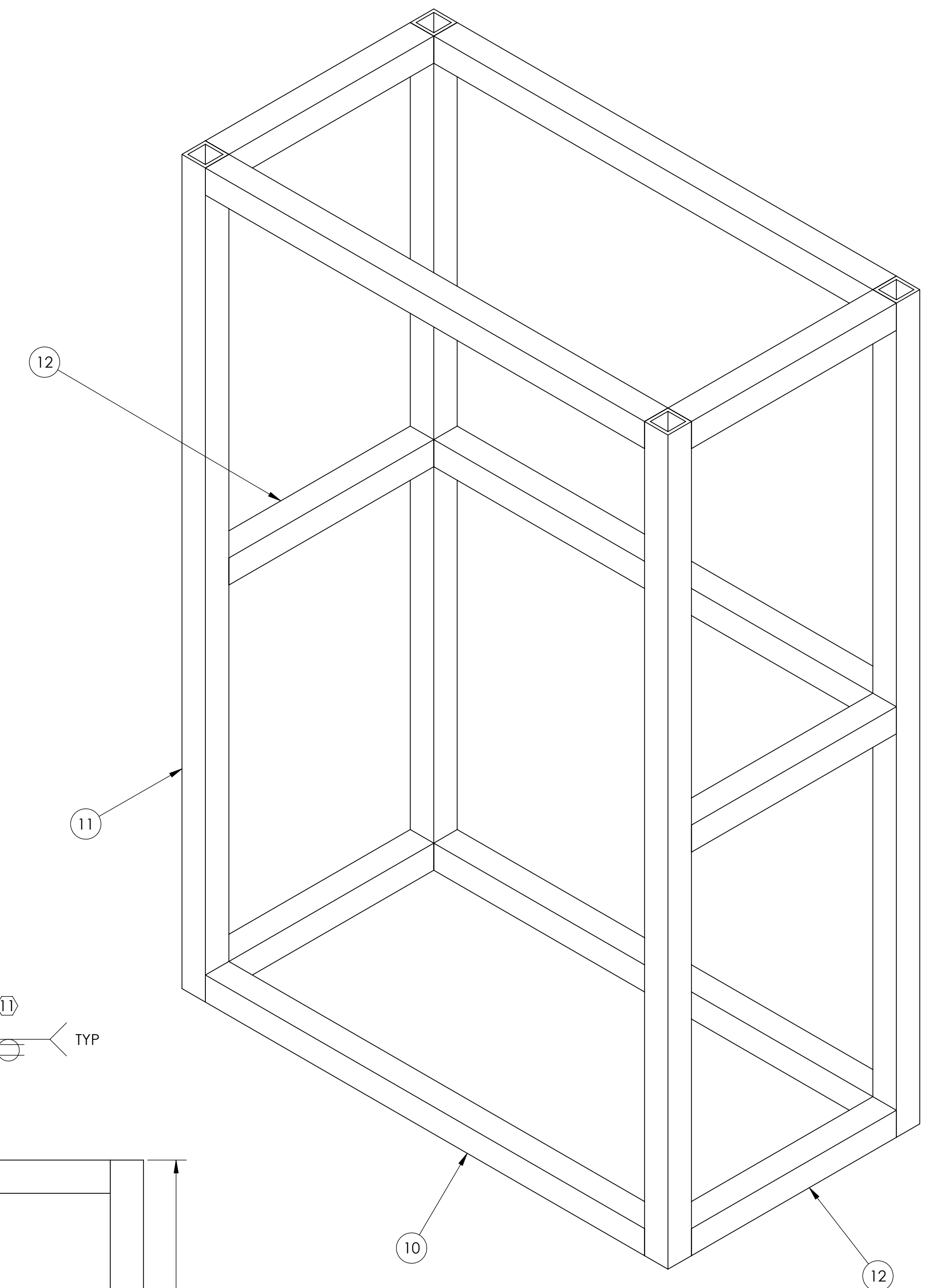
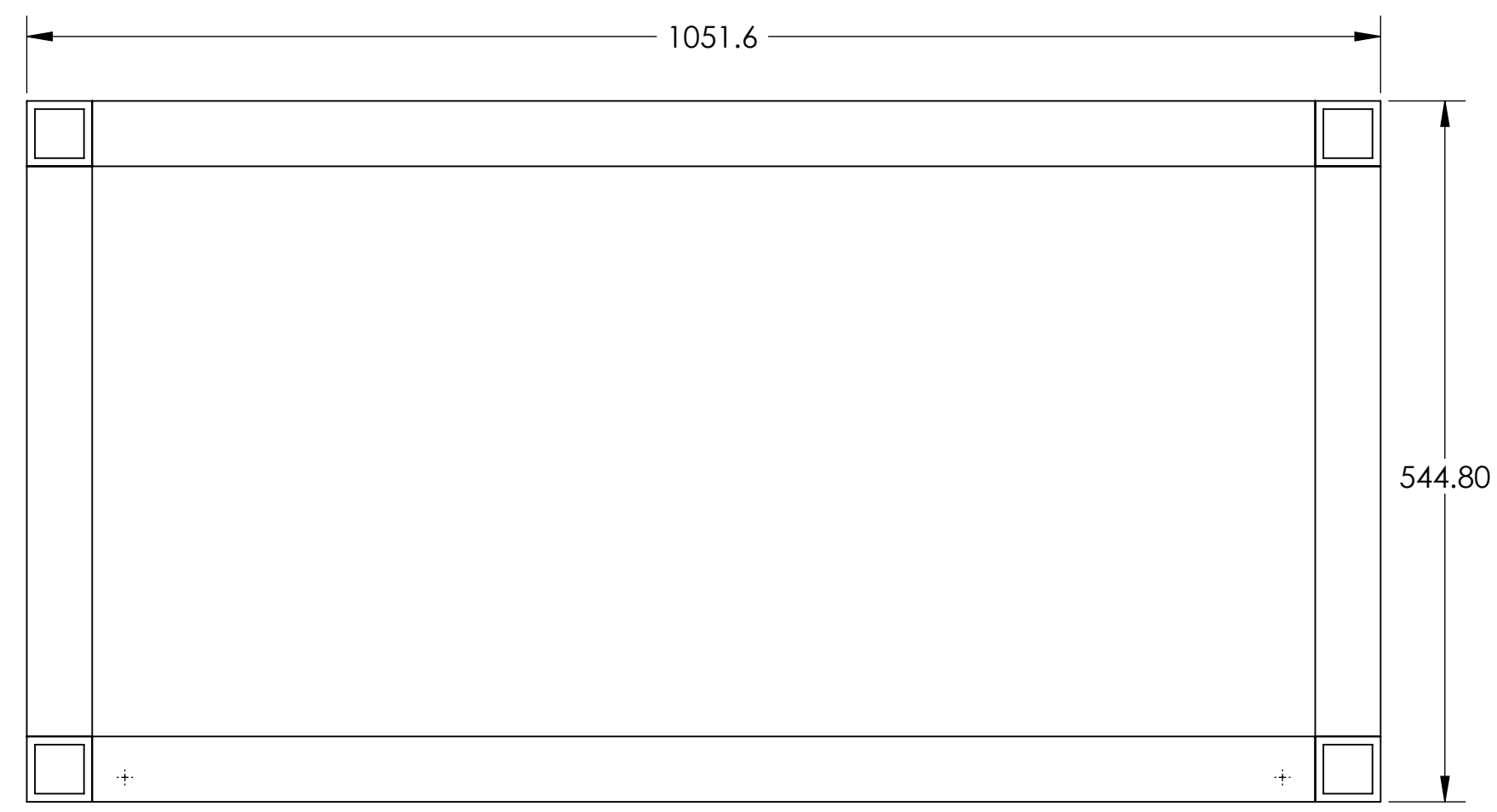
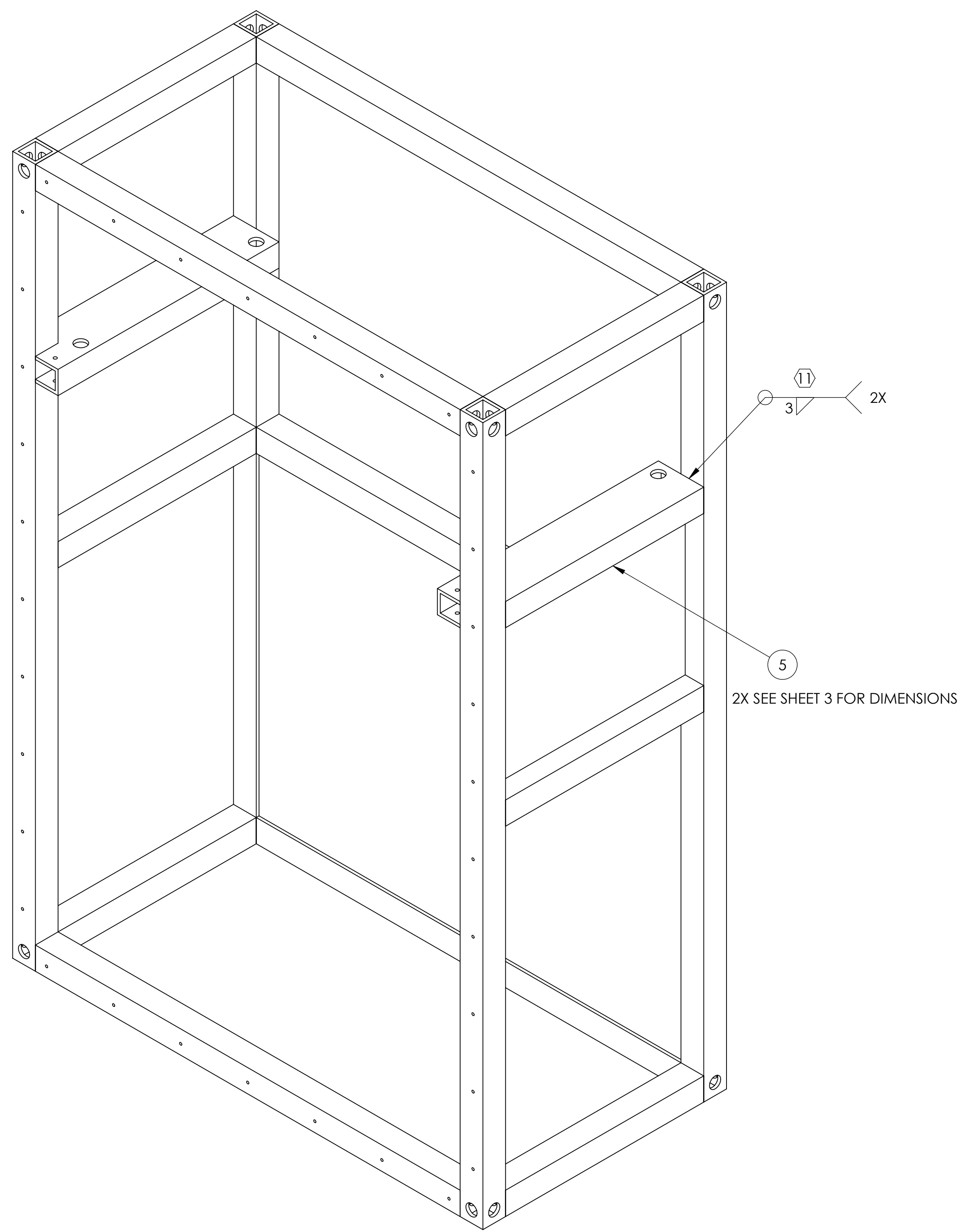

CUT LIST

ITEM NO.	QTY.	DESCRIPTION	LENGTH
10	5	50.8X50.8X6.35 TUBE	950
11	4	50.8X50.8X6.35 TUBE	1562.4
12	6	50.8X50.8X6.35 TUBE	443.2

BASIC WELDMENT
 MATERIAL: 2" SQUARE X .25" WALL
 6061 ALUM ALLOY TUBING
 SURFACE FINISH: AS RECEIVED

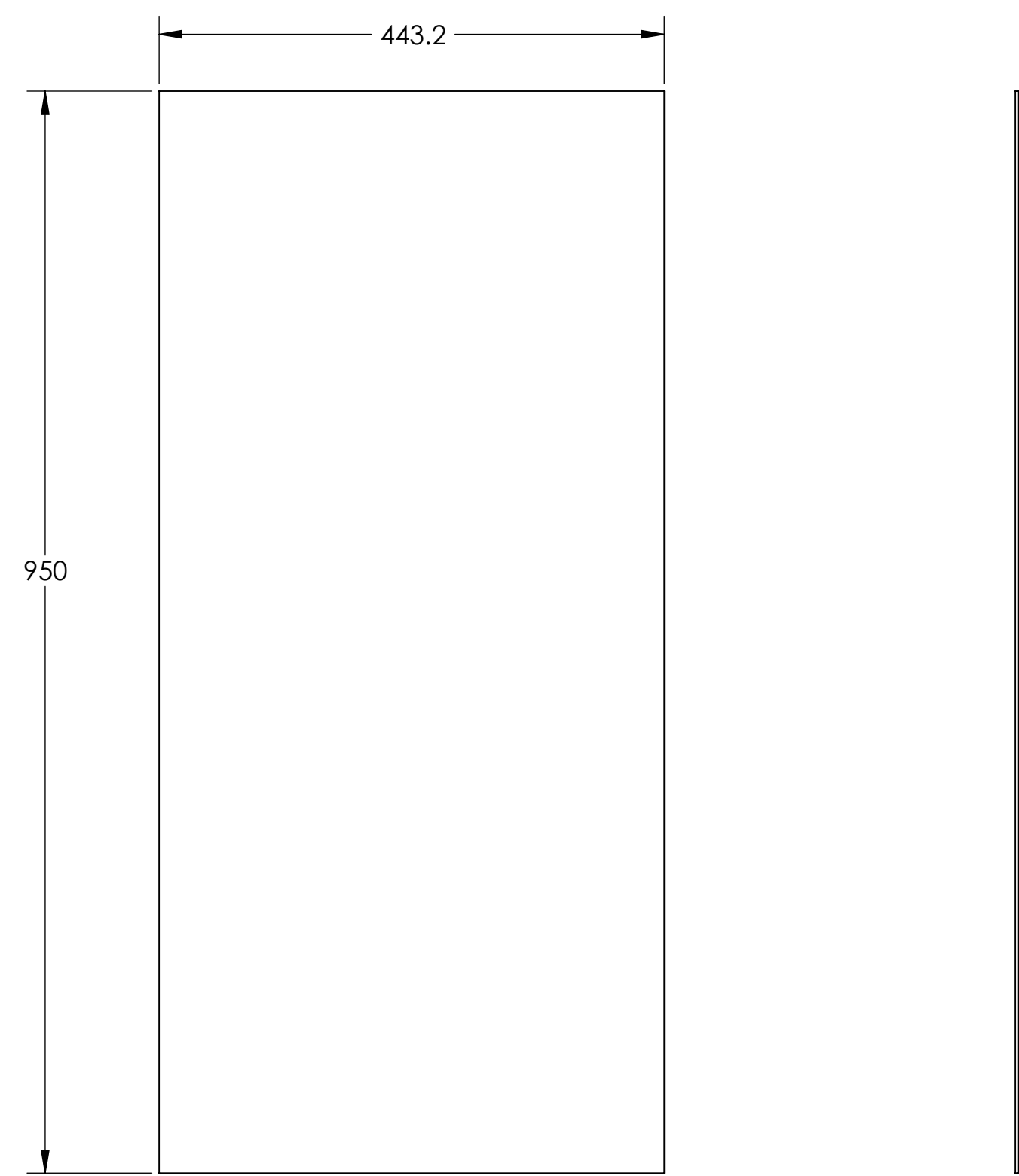

TOP AND BOTTOM SKIN
 MATERIAL: .12 THICK
 6061 OR 5052 ALUM ALLOY
 SURFACE FINISH: 32 μ inch
 2 REQ'D

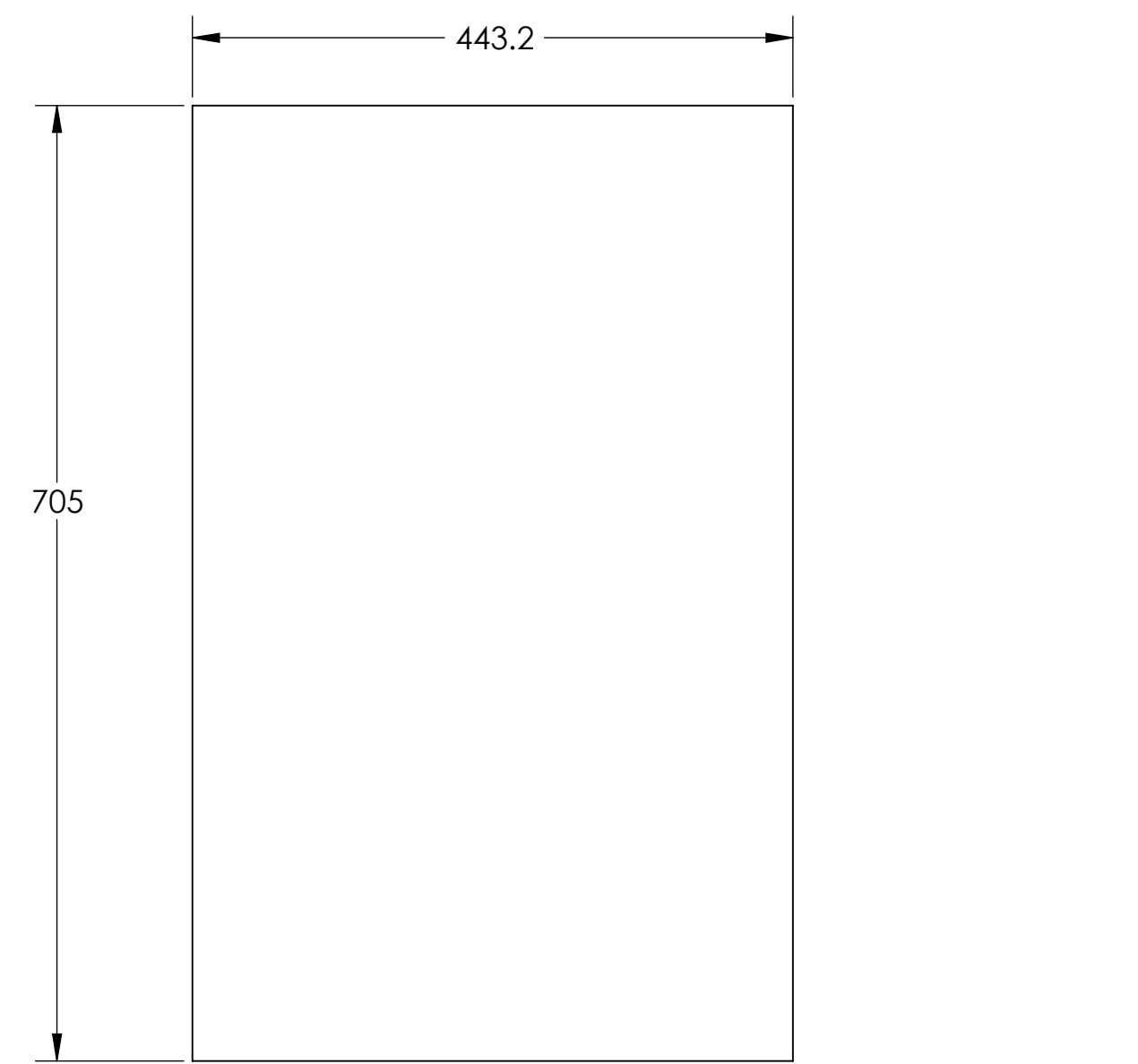

LOWER SIDE SKIN
 MATERIAL: .12 THICK
 6061 OR 5052 ALUM ALLOY
 SURFACE FINISH: 32 μ inch
 2 REQ'D

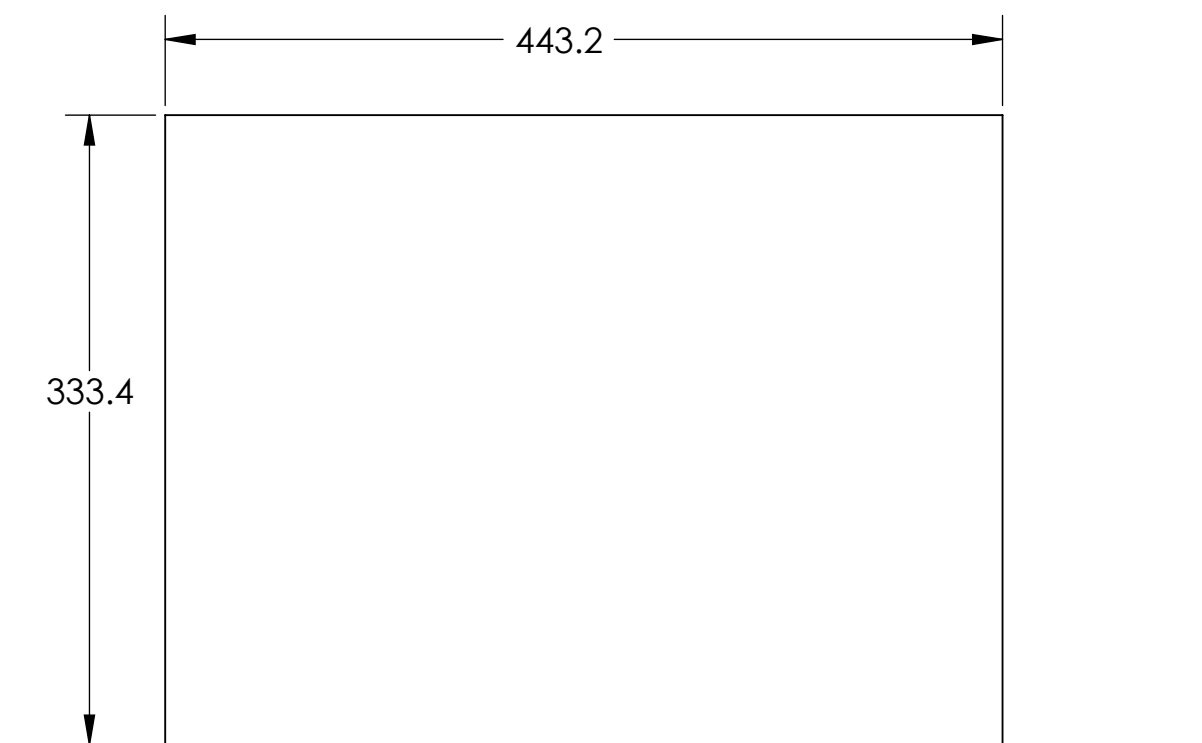

MIDDLE SIDE SKIN
 MATERIAL: .12 THICK
 6061 OR 5052 ALUM ALLOY
 SURFACE FINISH: 32 μ inch
 2 REQ'D

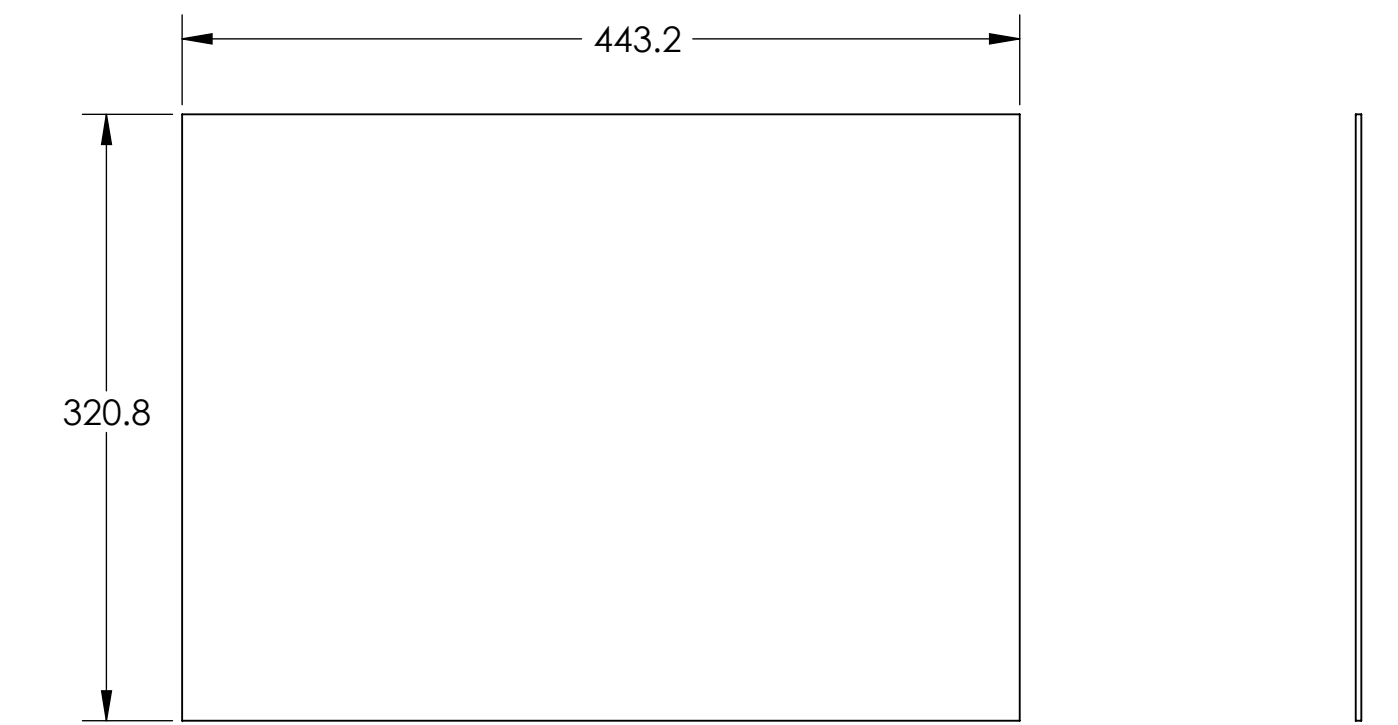

UPPER SIDE SKIN
 MATERIAL: .12 THICK
 6061 OR 5052 ALUM ALLOY
 SURFACE FINISH: 32 μ inch
 2 REQ'D

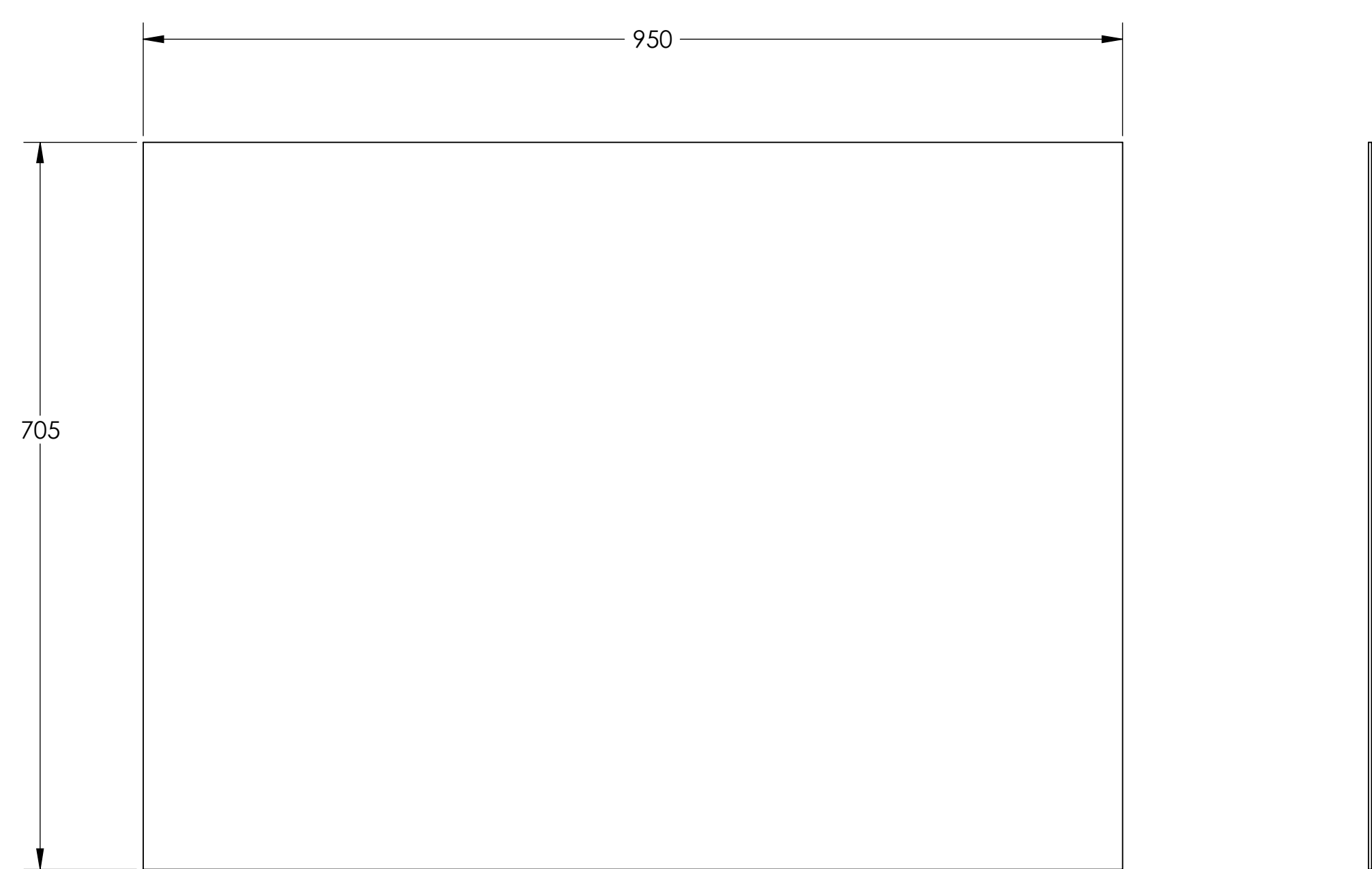

BACK SKIN
 MATERIAL: .12 THICK
 6061 OR 5052 ALUM ALLOY
 SURFACE FINISH: 32 μ inch
 2 REQ'D

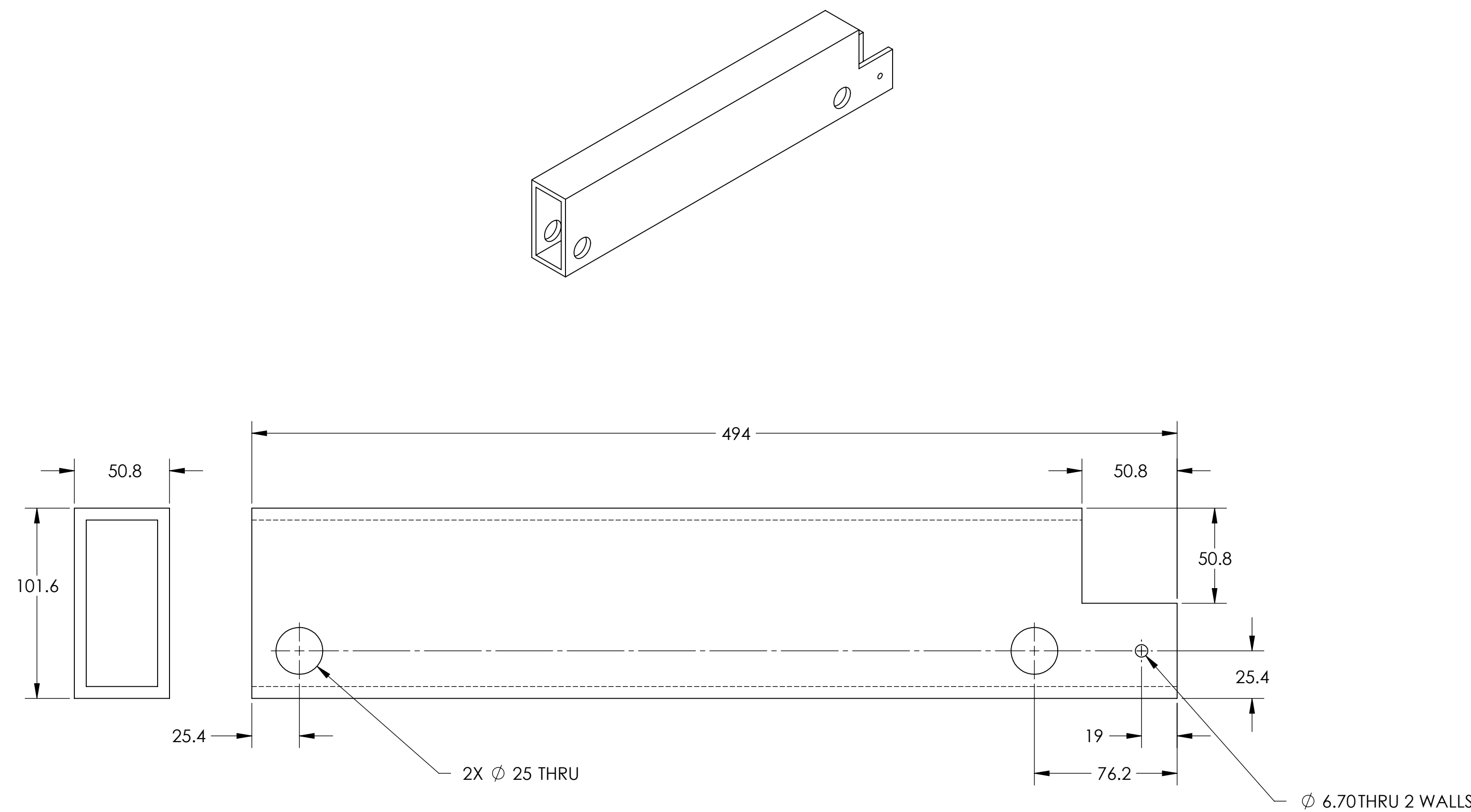

STRUCTURE SHELF
 MATERIAL: 2" X 4" X .25" WALL
 6061 ALUM ALLOY TUBING
 SURFACE FINISH: AS RECEIVED
 TO BE CHEMICALLY CLEANED / ETCHED BY
 ACID AND / OR CAUSTIC PROCESS PRIOR TO WELDING

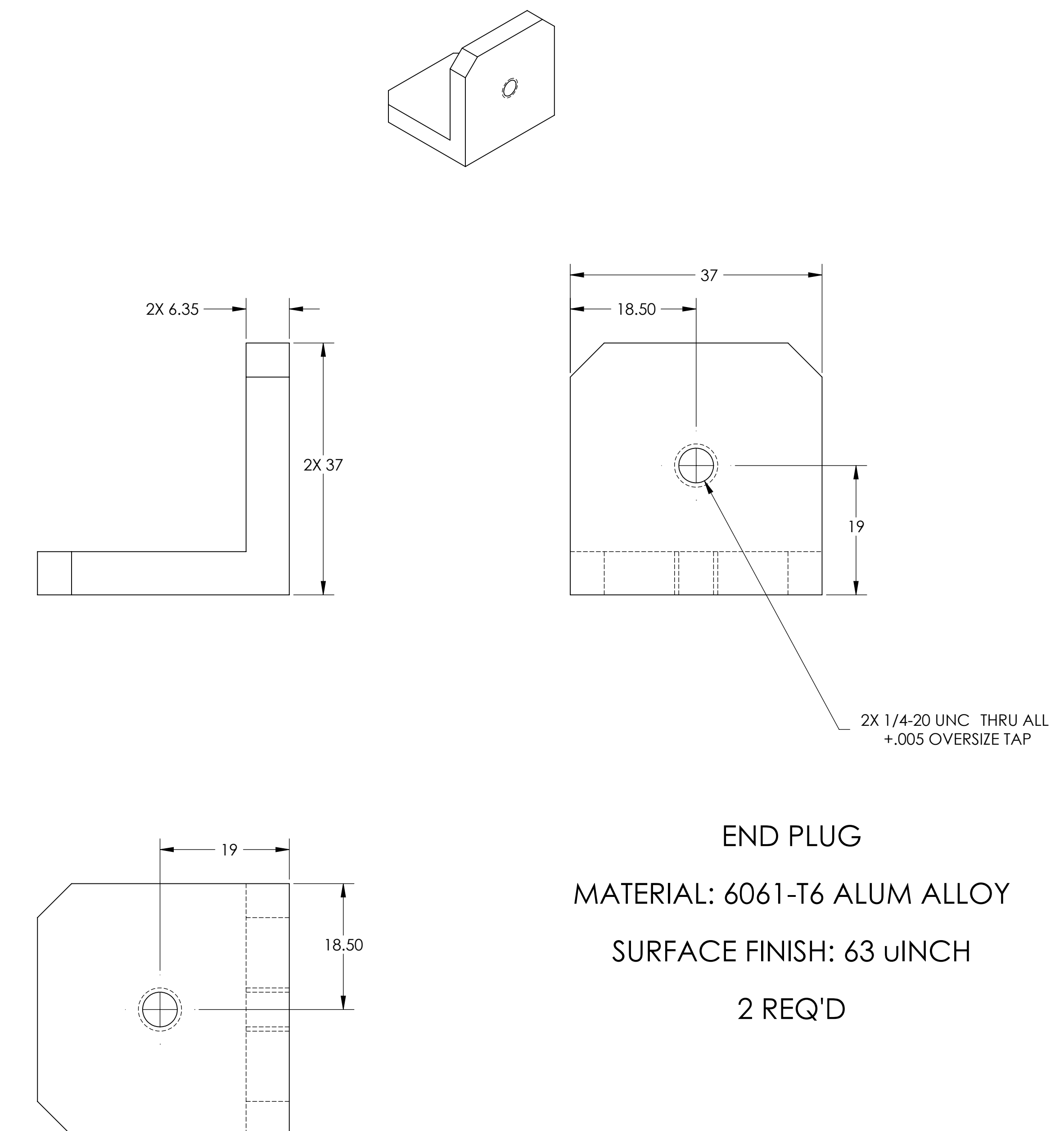

END PLUG
 MATERIAL: 6061-T6 ALUM ALLOY
 SURFACE FINISH: 63 μ INCH
 2 REQ'D