



**Statement of Work  
 Fabrication of pylons  
 for Advanced LIGO Optical lever**

The following documents are incorporated into and made a part this purchase order. Click on the following LIGO Document Control Center (DCC) links to access these documents or go on line to the LIGO Public DCC at <https://dcc.ligo.org/> to access the DCC#.

**1.0 Terms:**

<u>DCC #</u>	<u>Description</u>
<a href="#">C080185-v1</a>	Laser Interferometer Gravitational Wave Observatory (LIGO) Commercial Items or Services Contract General Provisions California Institute of Technology "Institute", LIGO Rev 11/12/08
<a href="#">F0810001-v4</a>	Technical Direction Memorandum.

**2.0 Quality Control:**

<u>DCC #</u>	<u>Description</u>
<a href="#">Q0900001-v4</a>	Advanced LIGO Supplier Quality Requirements, dated 2/10/10, describes following contractor/supplier QA/QC actions for this procurement:
<input checked="" type="checkbox"/> 3.1 Pre-Award Inspection	<input checked="" type="checkbox"/> 3.9 Discrepant Material Storage
<input checked="" type="checkbox"/> 3.2 Supplier In Process Quality Control	<input checked="" type="checkbox"/> 3.10 Quality Records
<input checked="" type="checkbox"/> 3.3 In Process Inspection	<input type="checkbox"/> 3.11 Drawing and Specification Change Control
<input checked="" type="checkbox"/> 3.4 Pre-Ship Inspection	<input checked="" type="checkbox"/> 3.12 Welding Certification
<input checked="" type="checkbox"/> 3.5 Receiving Inspection	<input checked="" type="checkbox"/> 3.13 End Item Data Package (including Certifications of Compliance)
<input checked="" type="checkbox"/> 3.6 Discrepant Material	<input type="checkbox"/> 4.1 Design Verification
<input type="checkbox"/> 3.7 Material Review Action	<input checked="" type="checkbox"/> 4.2 Raw Material Procurement
<input checked="" type="checkbox"/> 3.8 Material Review Actions at Contractor	<input checked="" type="checkbox"/> 4.3 Traceability of Materials
	<input checked="" type="checkbox"/> 4.4 Calibration Program
	<input type="checkbox"/> 4.5 Critical Interface
	<input checked="" type="checkbox"/> 4.6 Cleanliness
	<input checked="" type="checkbox"/> 4.7 Packaging
	<input checked="" type="checkbox"/> 4.8 Storage
	<input checked="" type="checkbox"/> 4.9 Transport
	<input type="checkbox"/> 4.10 Customs

For the above list the Supplier shall: 1) Identify the corresponding sections/paragraphs in their existing QA/QC system 2) meet or exceed the design requirements contained in the attached engineering documents for each area called out.

LIGO prefers to utilize the vendors existing QA/QC programs to the fullest extent possible consistent with the LIGO QA and QC requirements. All bidders are requested to submit a written description/plan of their existing QA/QC system with their quotes. The bidder must also submit QA/QC plans for managing subcontractor work and materials.

In the event that a prospective contractor lacks an existing quality system, the contractor/vendor shall develop and implement a quality assurance program in compliance with requirements negotiated at contract/PO award.

### **3.0 End Item Data Package:**

At the time of delivery of the parts, the Supplier shall also provide the following data, as a minimum:

- Any as-built modifications (with approval of the LIGO Contracting Officer) as mark-ups to the drawings
- Material certifications
- Dimensional & QC inspection reports—this shall include a report showing that parts have been inspected and fall within specified tolerances. Inspection is required on 1st, last plus 10% of each run.
- Certificate or statement of compliance with all contract and drawing process restrictions.

### **4.0 Included Documents:**

A set of drawings is included with this document. The lists of Assemblies and Drawings (by part number, revision and name) are included in table 1 and 2 of this document. The solid models (SolidWorks Professional 2010) used to create the drawings and assemblies are available for most of the models on request.

### **5.0 Scope:**

This RFQ is for the fabrication of rigid welded stainless steel pylons and machined parts detailed in the drawings included in this package. These pylons will be bolted and grouted by ALIGO to the floor of the ALIGO experimental halls to support the Optical lever launch and receiver optics. Machined parts are components of assemblies which are to be install on the pylons. These weldments and parts will have to be clean and free of grease.

### **6.0 Quantity Required:**

The total quantity required for each part, by drawing number is indicated in table 1 and 2.

### **7.0 Delivery Requirements:**

The deliveries are FOB at these destinations, i.e. the contractor has responsibility for shipping title and control of goods until they are delivered and the transportation has been completed. The contractor selects the carrier and is responsible for the risk of transportation and for filing claims for loss or damage.

#### **Shipping Locations:**

These items will be shipped to:

LIGO Livingston Observatory (LLO)  
Attn: Joe Hanson and Tom Gentry  
19100 LIGO Lane  
Livingston, LA 70754

LIGO Hanford Observatory (LHO)  
Attn: Hugh Radkins and Jodi Fauver  
127124 North Route 10  
Richland, WA 99354

California Institute of Technology  
391 S. Holliston Ave.  
Pasadena, CA 91106  
Extension: 4893  
Mail Code: 1-85

Shipping Containers:

The contractor is responsible for providing shipping containers and transportation which protects these parts from damage from the transportation environment (weather, handling, accidents, etc.).

## **8.0 Manufacturing:**

### **8.1 Precedence**

The Statement of Work (SOW) sections below regarding processing or fabrication of the parts are meant to convey the scope and nature of the requested work. If there is a conflict between the SOW and the drawing, the drawing has precedence. The parts are to be produced using the drawings which will be included in the final released SOW package. If there are discrepancies between the drawings and the CAD model, the drawings takes precedence.

### **8.2 Welding**

Welds are to meet MIL-STD-2219, CLASS C.

#### **8.2.1 Weld Supplemental Notes**

All lip and fold welding will be 50% stitch welding both on the fold and on the lip sides. The left and right-hand pylons are, apart from the mirror image, identical. Any missing information for the right hand pylon can be extracted from the drawings of the left ended one (they are obtained by simply folding the metal sheets in the opposite direction and welding them in mirror image fashion).

### **8.3 Finishing**

As rolled bright stainless steel finish

### **8.4 Marking**

Marking location is shown on the drawings.

All parts must be marked with a part number, revision code and serial number at the location indicated on the drawing. Marking is to be accomplished by mechanically scribing, stamping or engraving (no dyes or inks).

If not indicated in the drawing, mechanically scribe, stamp or engrave as follows:

<drawing number> - <revision code>, <type number if applicable>

<unique 3 digit serial number starting at 001 for the first part and incrementing thereafter>

As an example:

D0900026-v1

S/N – 001

The serial number must be a sequential 3-digit number, starting with 001, for each part.

Also where indicated, mechanically scribe, stamp, or engrave (no dyes or inks) any LABELS shown on drawing sheets.

## 9.0 Delivery Schedule:

Please refer to table 1 and 2 for the delivery schedule. Early shipping is acceptable and all shipping should be discussed with LIGO contract technical officer.

**Table 1 Weldments & Footings**

*Total quantities required for each finished unit, destinations and delivery dates*

Item Num	Drawing Number	Description	Total Quantity Ordered	WELDMENT "D" NUMBER COMPONENTS BOM	ASSEMBLY DELIVERY QUANTITIES & SCHEDULE		
					CalTech Pasadena CA	LIGO Hanford WA	LIGO Livingston, LA
					1/3/2011	3/30/2011	2/28/2011
1	<a href="#">D1000452-v2</a>	aLIGO AOS OpLev TX Pier Weldment (TM)	12	(E1000332-v1) <a href="#">D1001655</a> <a href="#">D1000426</a> <a href="#">D1000425</a>	2	6	4
2	<a href="#">D1001292-v1</a>	aLIGO AOS OpLev & PhotCal RX Pier Weldment LH	6	(E1000333-v1) <a href="#">D1000835</a> <a href="#">D1000594-1</a> <a href="#">D1000595-1</a> <a href="#">D1000596-1</a>	1	3	2
3	<a href="#">D1001297-v1</a>	aLIGO AOS OpLev & PhotCal RX Pier Weldment RH	6	(E1000334-v1) <a href="#">D1000835</a> <a href="#">D1000594-2</a> <a href="#">D1000595-2</a> <a href="#">D1000596-2</a>	1	3	2
4	<a href="#">D1001301-v1</a>	aLIGO AOS OpLev TX Pier Weldment (PR3, SR3)	6	(E1000335-v1) <a href="#">D1001857</a> <a href="#">D1000426</a> <a href="#">D1001611-2</a>	1	3	2
5	<a href="#">D1002207-v2</a>	aLIGO AOS OpLev RX Pier Weldment LH (PR3, SR3)	4	N/A	1	1	2
6	<a href="#">D1002208-v1</a>	aLIGO AOS OpLev RX Pier Weldment RH (SR3)	2	N/A	N/A	1	1
7	<a href="#">D1001854-v1</a>	aLIGO AOS OpLev TRX Pier Weldment (HAM)	12	(E1000336-v1) <a href="#">D1001853</a> <a href="#">D1000426</a> <a href="#">D1001611-1</a>	1	7	4
8	<a href="#">D1000434-v2</a>	aLIGO AOS Pier Footing 1	33	N/A	5	18	10
9	<a href="#">D1000836-v2</a>	aLIGO AOS Pier Footing 4	13	N/A	3	6	4

**Table 2 Mechanical Parts***Total quantities required for each part, destinations and delivery dates*

Item Num	Drawing Number	Description	Total Quantity Ordered	BOM	DELIVERY QUANTITIES & SCHEDULE		
					CalTech Pasadena CA	LIGO Hanford WA	LIGO Livingston LA
					1/3/2011	3/30/2011	2/28/2011
1	<a href="#">D1000502-v3</a>	aLIGO AOS OpLev TX Height Tube	<b>36</b>	N/A	4	20	12
2	<a href="#">D1000509-v1</a>	aLIGO AOS OpLev TX Mounting Plate	<b>12</b>	N/A	2	5	5
3	<a href="#">D1000510-v1</a>	aLIGO AOS OpLev TX Mounting Plate, 7.5 deg. Wedge	<b>3</b>	N/A	2	1	N/A
4	<a href="#">D1001449-v2</a>	aLIGO AOS OpLev Large Telescope Mount	<b>14</b>	N/A	3	6	5
5	<a href="#">D1001452-v1</a>	aLIGO AOS OpLev TX Enclosure Base	<b>14</b>	N/A	3	6	5
6	<a href="#">D1001627-v1</a>	aLIGO AOS OpLev Mounting Plate (HAM)	<b>19</b>	N/A	1	12	6
7	<a href="#">D1001628-v1</a>	aLIGO AOS OpLev Mirror Base	<b>19</b>	N/A	1	12	6
8	<a href="#">D1001646-v1</a>	aLIGO AOS OpLev Telescope Mount Base	<b>19</b>	N/A	2	11	6
9	<a href="#">D1001647-v1</a>	aLIGO AOS OpLev Telescope Clamp	<b>19</b>	N/A	1	12	6
10	<a href="#">D1001670-v1</a>	aLIGO AOS OpLev Auxiliary View Finder Telescope Mount	<b>11</b>	N/A	1	5	5
11	<a href="#">D1001993-v1</a>	aLIGO AOS OpLev TX Mounting Plate (PR3, SR3)	<b>8</b>	N/A	1	4	3
12	<a href="#">D1001611-v1</a>	aLIGO AOS OpLev Pier Table (HAM, PR3, SR3)	<b>20</b>	N/A	1	12	7
13	<a href="#">D1000428-v1</a>	aLIGO AOS OpLev TX Mounting Base	<b>20</b>	N/A	3	7	10
14	<a href="#">D1000836-v2</a>	aLIGO AOS Pier Footing 4	<b>12</b>	N/A	2	6	4
15	<a href="#">Sheet 10 of 10 from drawing D1002207-v2</a>		<b>1</b>	N/A	1	N/A	N/A

# LIGO Document Control Center

operated by [Caltech](#) and [MIT](#) :: supported by the [National Science Foundation](#)

## Accessing the DCC

[LIGO User](#) (upload and access all documents)

[Public User](#) (view public documents only)

## Public Document Search

[Old DCC Search](#) Google Public Document Search:

## Using the DCC

The Document Control Center is the central repository for electronic documents related to [LIGO](#).

In order to access private documents, you will be prompted for your LIGO account name and password, of the form [albert.einstein](#). If you do not have a LIGO account, you may request one from the [LIGO Directory](#). If you have forgotten your password you may [reset it](#).

The LIGO DCC is built on top of [DocDB](#). For more information on the DCC, please consult the [User's Manual](#).

## NEWS

All type E documents (Engineering) from the old document system have been [migrated](#).

All type D documents (Drawings) from the old document system have been [migrated](#).

The DCC was updated on October 8, 2009 to add a faster search engine, apply more restrictive author and file content searches by default, and to add a richer group hierarchy for document access starting with an Advanced LIGO Business group. Further details may be found [here](#).

The DCC was updated on May 7, 2009 to offer support for Author Groups, granting access to documents based on who is an author, and adding custom access groups apart from the initial set of hierarchical groups. Further details may be found [here](#).

The DCC was updated on February 26, 2009 to offer initial support for the public release of documents and QA approval of document metadata by the DCC support team. The full list of bugs and enhancements associated with this release are linked to the [version 2.1.0 support ticket](#).

The new DCC was released to the LSC on Jan 26, 2009 as announced [here](#).

---

[Contact Us](#)



*LIGO Laboratory / LIGO Scientific Collaboration*

LIGO-Q0900001-V4-P

*Advanced LIGO*

February 10th, 2010

---

**Advanced LIGO Supplier Quality Requirements**

---

Mick Flanigan, Rod Luna, William Tyler

Distribution of this document:  
LIGO Scientific Collaboration

This is an internal working note  
of the LIGO Laboratory.

**California Institute of Technology**  
**LIGO Project – MS 18-34**  
**1200 E. California Blvd.**  
**Pasadena, CA 91125**  
Phone (626) 395-2129  
Fax (626) 304-9834  
E-mail: info@ligo.caltech.edu

**Massachusetts Institute of Technology**  
**LIGO Project – NW22-295**  
**185 Albany St**  
**Cambridge, MA 02139**  
Phone (617) 253-4824  
Fax (617) 253-7014  
E-mail: info@ligo.mit.edu

**LIGO Hanford Observatory**  
**P.O. Box 1970**  
**Mail Stop S9-02**  
**Richland WA 99352**  
Phone 509-372-8106  
Fax 509-372-8137

**LIGO Livingston Observatory**  
**P.O. Box 940**  
**Livingston, LA 70754**  
Phone 225-686-3100  
Fax 225-686-7189

<http://www.ligo.caltech.edu/>

## Revision History

Revision LTR	Released By	Pages Affected	Date	DCN Number
00	Mick Flanigan	All	08/15/08	N/A
01	Mick Flanigan	All	08/29/08	N/A
02	Mick Flanigan	5, 6	02/10/10	N/A

### Advanced LIGO QA Officer:

**Mick Flanigan**  
**LIGO Hanford Observatory**  
 P.O. Box 1970  
 Mail Stop S9-02  
 Richland WA 99352  
 Phone 509-372-8175  
 Mobile: 503-701-6346  
 Fax 509-372-8137

E-mail: [Flanigan\\_m@ligo-wa.caltech.edu](mailto:Flanigan_m@ligo-wa.caltech.edu)

### Advanced LIGO Customs Officer:

**Rod Luna**  
**California Institute of Technology**  
 LIGO Project – MS 18-34  
 1200 E. California Blvd.  
 Pasadena, CA 91125  
 Phone (626) 395-3186  
 Fax (626) 304-9834

E-mail: [luna\\_r@ligo.caltech.edu](mailto:luna_r@ligo.caltech.edu)



## Contents

<b>1. Quality Program Guideline</b> .....	5
<b>1.1. Purpose of this Document</b> .....	5
<b>1.2. Purpose of a Quality Program</b> .....	5
<b>1.3. Relevant Documents</b> .....	6
<b>2. Procurement Process</b> .....	6
<b>2.1. Pre-Procurement Activities</b> .....	6
<b>2.2. LIGO Procurement Documentation</b> .....	6
<b>3. Manufacture, Assembly and Receiving Inspection Requirements</b> .....	7
<b>3.1. Pre-Award Inspection</b> .....	7
<b>3.2. Supplier in Process Quality Control</b> .....	7
<b>3.3. In Process Inspection</b> .....	8
<b>3.4. Pre-Shipment Inspection</b> .....	8
<b>3.5. Receiving Inspection</b> .....	9
<b>3.6. Discrepant Material</b> .....	9
<b>3.7. Material Review Action</b> .....	10
<b>3.8. Material Review Actions at Contractor</b> .....	10
<b>3.9. Discrepant Material Storage</b> .....	10
<b>3.10. Quality Records</b> .....	10
<b>3.11. Drawing and Specification Change Control</b> .....	10
<b>3.12. Welding Certifications</b> .....	11
<b>3.13. End Item Data Package</b> .....	11
<b>4. Supplier Quality Assurance Review: Definitions</b> .....	12
<b>4.1. Design Verification</b> .....	12
<b>4.2. Raw Material Procurement</b> .....	12
<b>4.3. Traceability of Materials</b> .....	12
<b>4.4. Calibration Program</b> .....	12
<b>4.5. Critical Interfaces</b> .....	13
<b>4.6. Cleanliness</b> .....	13
<b>4.7. Packaging</b> .....	13

- 4.8. Storage ..... 14
- 4.9. Transport ..... 14
- 4.10. Customs ..... 14
- 5. System Integration and Commissioning Inspection Requirements..... 15
  - 5.1. System Integration Inspection Process ..... 15
  - 5.2. System Integration Acceptance Test..... 15
- 6. Advanced LIGO QA Inspection Workflow Chart..... 16
- 7. Glossary ..... 17

## **1. Quality Program Guideline**

### **1.1. Purpose of this Document**

The purpose of this document is to provide guidance, requirements and general procedures for a Quality Assurance and Quality Control program (QA/QC) as it applies to procurements and contracted effort. It provides recommendations on the policies and phrases to be used in all “Request for Proposal” (RFP) or “Request for Quote” (RFQ) solicitations to be sent to prospective suppliers and vendors for Advanced LIGO components, parts, or services. The audience for this document is the LIGO technical and procurement staff, as well as the potential suppliers bidding against and RFQ/RFP. Section 3 and 4 provide detailed descriptions of the applicable sections in the RFQ/RFP that are checked by the LIGO procurements and Engineering teams, providing suppliers definitions to assist in formulating the bids.

Advanced LIGO is a project undertaken by the LIGO Laboratory (or simply ‘LIGO’).

This document is intended for use when the supplier is manufacturing and/or assembling components, or providing services, which require a LIGO review of the supplier QA/QC monitoring. LIGO engineering, projects, procurement and QA teams will make determinations on the applicability of this document on a case by case basis.

### **1.2. Purpose of a Quality Program**

A Quality Program is a framework for ensuring completeness, correctness, reliability and maintainability of a system and its components. The specific goals and deliverables of a Quality program for Advanced LIGO are:

- 1.2.1. All designs are to be carefully reviewed and finalized through an Advanced LIGO Design Review process.
- 1.2.2. The supplier has an accurate and complete set of design specifications, drawings, and material and performance characteristics.
- 1.2.3. The supplier maintains an internal quality program to ensure systems are fabricated, assembled, and tested to specifications provided by LIGO.
- 1.2.4. The supplier ensures appropriate workmanship, including but not limited to certification, safety, handling, cleanliness and documentation.
- 1.2.5. The supplier will provide appropriate packaging and shipping methods to protect the component(s) from damage in transit.
- 1.2.6. The supplier shall provide reliability estimates, maintenance procedures and schedules, if applicable.

1.2.7. Both LIGO and the supplier may, in general (depending upon the particular aspects and criticality of the effort), participate in pre-award audits, in process inspections; post-assembly and post-install inspections and acceptance testing. Enable LIGO and the supplier to establish specific expectations, and mechanisms, up front on remedying issues which arise during fabrication and testing, where the component does not meet design, assembly or performance specifications due to improper manufacturing, faulty sub-components, or improper fit or performance of critical interfaces, or improper packaging and shipping methods. An example is a Material Review Board (MRB)

### **1.3. Relevant Documents**

LIGO-E010613-02, Generic Requirements & Standards for Detector Subsystems [in particular section 9]

LIGO-E030350-A, Drawing Requirements

Other documents specific to the given RFP/RFQ will be provided as part of the package and not referenced here. Also additional documents may be released once the bid process is complete and contract award is taking place.

## **2. Procurement Process**

### **2.1. Pre-Procurement Activities**

RFPs and RFQs shall be written to use contractor/vendor existing QA systems to the fullest extent possible consistent with the provisions outlined in LIGO Quality Assurance Plan M960076-P. Should a contractor lack an existing quality system, the contractor shall develop a quality assurance plan in compliance with the requirements negotiated at contract award.

### **2.2. LIGO Procurement Documentation**

LIGO will provide the supplier with the following documentation in support of the bid process (if and as applicable):

- 2.2.1. Technical documents, drawings, and specifications, identified by revision.
- 2.2.2. Preservation, packaging, storage, and shipping requirements.
- 2.2.3. Requirements for component longevity.
- 2.2.4. Specific Inspection and Test requirements.
- 2.2.5. End Item Data Package requirements.
- 2.2.6. Requirements for source inspection by customer.
- 2.2.7. Safety Performance requirements.

### **2.3. Supplier Bid Package Requirements**

As part of the bid package, and for consideration in contract award, the supplier shall confirm the intent to comply with the following Quality Program requirements (if and as applicable):

- 2.3.1. Provide with the deliverables all supplier-generated technical documents, drawings, and specifications, identified by revision, with all red line items updated in electronic format (source files and Adobe Acrobat) for the as-built system or component.
- 2.3.2. Adhere to all shipping, packaging and cleanliness requirements as required in the Advanced LIGO design documents.
- 2.3.3. Submit all tests and inspection reports to LIGO immediately following completion, in agreed upon electronic format.
- 2.3.4. Fulfill requirements for source inspection by customer, which can include a pre-award inspection, in process audits, as well as a pre-ship inspection.
- 2.3.5. Provide a copy of their existing QA/QC program, with a strategy for implementing in conformance to Advanced LIGO requirements, if necessary.

## **3. Manufacture, Assembly and Receiving Inspection Requirements**

### **3.1. Pre-Award Inspection**

Prior to contract award LIGO staff may perform an audit of the prospective supplier quality programs. The need to perform an audit will be determined by the Contracting Officer's Technical Representative (COTR), the subsystem leader and/or the chief engineer, based on criticality, cost, and use case of components. The audit scope includes but is not limited to:

- Calibration program review.
- Maintenance and reliability programs for manufacturing equipment.
- Critical worker certification levels (i.e., welding, electrical, CNC, etc.).
- Supplier QA/QC program and how it will be implemented for Advanced LIGO contracts.
- Manufacturing methodologies, especially as regards cleanliness and use of approved materials and fluids.
- Cleaning and packaging methodologies compared to RFP/RFQ requirements.

### **3.2. Supplier in Process Quality Control**

Critical processes shall be controlled using manufacturing travelers or procedures established and qualified prior to LIGO equipment production. As an example, these manufacturing procedures shall include:

- Equipment to be used including calibration requirements.

- Identification of operational constraints.
- Workmanship standards.
- Call-outs for inspections, tests, and other verification processes.
- Acceptance criteria.

### **3.3. In Process Inspection**

In-process inspections shall be performed where subsequent assembly stages will prevent/limit inspection access, and to detect defects early in the process. In-process inspections shall be identified in fabrication and assembly by planning Mandatory Control Points (MCPs). Suppliers shall document all deficiencies and discrepancies, and report immediately to LIGO. Electronic format, via email transmission, is the preferred method of report delivery.

### **3.4. Pre-Shipment Inspection**

Supplier shall inspect and validate system integrity prior to shipment of equipment to any LIGO site. LIGO may choose to send a representative to participate in inspections deemed critical. Pre-shipment inspection of equipment to be delivered to the LIGO observatories shall include the following (as appropriate):

- End Item Data Package review.
- Certificate of Compliance, where required.
- Shipping documentation such as the manifest or shipper.
- LIGO property control documentation, when LIGO materials are in possession of a supplier.
- Verification of the adequacy of the shipment packaging and weather protection.
- Evidence of contractor quality assurance acceptance.
- Evidence of safety requirements compliance.
- Verification that transportation environmental controls and monitoring requirements will be satisfied.

### 3.5. Receiving Inspection

Receiving inspection will be performed to ensure that articles procured by LIGO, or its suppliers, conform to contractual or procurement document requirements prior to release of payment to supplier. This will be a time-critical activity. Receiving inspection includes the following (as applicable):

- Inspection of incoming hardware and documentation for compliance to applicable Drawings, Specifications, and/or other documentation specified by the procurement documentation.
- Evidence of acceptance by contractor/supplier inspection.
- Evidence of source inspection acceptance as applicable.
- Identification of deviations from requirements specified in the procurement documentation.
- Securing dispositions of discrepant materials.
- Verification that equipment complies with shipping, handling and safety constraints.
- Identification of hardware acceptance status with appropriate labels.
- Documentation of receiving inspection, one copy stored at site and a second sent to procurements for potential release of payments, shall be completed by LIGO personnel.

### 3.6. Discrepant Material

When an article does not conform to applicable engineering design documentation it shall be identified as non-conforming. It shall be segregated from on-going work operations, and held for further action. When a discrepancy has been identified and documented it shall be reported immediately to the responsible LIGO science or engineering personnel and the LIGO Quality Assurance Officer.

Only LIGO personnel responsible for the item submitted to the discrepancy evaluation process, or their designees are authorized to issue dispositions for the discrepant item. Initial discrepant hardware dispositions include the following:

- Rework to drawing or specification.
- Repair: Articles that are modified to a useable state but remain nonconforming to drawing or specification requirements.
- Return to vendor.
- Use-as-is: Articles that are useable in the present state without further processing.
- Suspended Action: Articles of which resolution is determined after drawing or specification change, or after hardware fit check.
- Scrap.

LIGO quality assurance representative concurrence is required for all LIGO science or engineering personnel discrepant material dispositions.

### **3.7. Material Review Action**

The Material Review Action shall determine dispositions of nonconforming articles that cannot be resolved by the initial discrepant hardware disposition. For discrepant articles submitted to Material Review Action the LIGO Project Manager shall, with the concurrence of the LIGO Quality Assurance Officer, determine the final disposition.

### **3.8. Material Review Actions at Contractor**

Material Review Actions conducted at a contractor are the responsibility of that contractor. LIGO personnel will not participate as members of the contractor's Material Review Board. However, Contractor Material Review Actions will be subject to review and concurrence by LIGO engineering and quality assurance personnel. Contractor Material Review Actions shall become a part of the EIDP.

### **3.9. Discrepant Material Storage**

Discrepant Material shall be identified and to the degree possible, separated from acceptable material until the disposition action has been completed.

### **3.10. Quality Records**

The LIGO Quality Assurance Office will maintain quality records which provide evidence of inspections, tests, as built configuration, and Material Review Actions.

The LIGO Project Office will establish a facility and procedures for the long term storage of LIGO project QA documentation and other related records. Satellite record storage facilities may also be established at the observatory sites for equipment or materials located at or peculiar to the site. This data shall be maintained for at least the duration of the 20 year operational life of the observatories.

### **3.11. Drawing and Specification Change Control**

All drawings and specifications will be controlled by the suppliers Quality Assurance Department, including receipt and distribution. Upon receiving the order/contract, all drawings will be verified as to correct number and revision.

All such documents shall be marked to indicate that they have been included in the system. Supplier shall ensure distributed copies of master documents must be marked as controlled or uncontrolled. Controlled documents should be numbered serially (1,2,3...n) and recorded in the contract file.



A controlled document must be kept updated at every document change or engineering change. The contract administrator under the guidance of QA will insure that all controlled documents, whether in house or out, will be updated.

Controlled documents must be returned to QA or the contract administrator at the end of their use. At that time they will be removed from the controlled list.

The supplier shall take appropriate measures to control obsolete and uncontrolled documents from contaminating the contract work. This includes a method of marking, checking out, or destroying.

Upon receipt of drawing and specification changes, the supplier Quality Assurance or other appropriate personnel will remove obsolete drawing specification and issue the latest drawing specification to proper personnel. Obsolete drawings will be marked “obsolete” if needed for record or destroyed.

### **3.12. Welding Certifications**

For any work on Advanced LIGO parts or components that requires welding, Caltech will require any contractor to supply certifications for the welders performing the work. Certifications must show valid dates, as well as certified welding type/class for the work to be done. All welders who will be performing work will be required to be certified for the work, and samples of work may be requested.

### **3.13. End Item Data Package**

The end item data package is the set required documents to be supplied to LIGO upon delivery of ordered parts or services, which may include but is not limited to the following items:

- As Built Modifications (with approval of the LIGO Contracting Officer) as markups to the drawings
- Material Certifications
- Dimensional and QC reports, including all test procedures and results
- Certificate or Statement of Compliance with all contract and process restrictions
- Welding Certifications

Specific items above pertinent to a given contract will be called out in the statement of work, as well as any additional EIDP requirements not listed above.

## **4. Supplier Quality Assurance Review: Definitions**

### **4.1. Design Verification**

At appropriate stages of the design process, design verification shall be performed to ensure that the proposed design meets the requirements (see M0500220). This will normally be accomplished through the Design Review process. However, additional design verifications may be instituted where critical elements are involved, or where a potential for errors may have significant impact to functional performance, cost or schedule. In particular if a supplier/contractor/vendor is tasked with design effort, LIGO must plan to review the delivered design before authorization to fabricate.

### **4.2. Raw Material Procurement**

Suppliers of raw materials shall provide certifications and country of origin indicating that materials being provided are in compliance with requirements specified in the procurement documents. Reports of chemical and physical tests are required for critical usage materials to verify conformance to applicable specifications and drawings.

### **4.3. Traceability of Materials**

Materials considered critical for LIGO observatories' successful operations, or used in the vacuum system, shall require identification and country of origin by lot, batch or production run. Materials process records shall be delivered by the supplier and retained in the LIGO Documentation Control Center. Questions regarding traceability requirements for specific items should be directed to the LIGO Quality Assurance Officer.

### **4.4. Calibration Program**

The supplier shall maintain a calibration program of all instruments and tools requiring calibration. Schedules of calibration shall be in accordance with the instrument or tool manufacturers' recommendations. Labels on the instrumentation and tools or their cases shall be in plain view, and have a calibration record referenced to a report on file with the supplier, as well as a date of performed calibration, due date for next cycle, as well as a signature and disposition of calibration (pass or fail). All instruments that have failed calibration will be required to have on file a document showing repair, repair facility, reason for out of spec, and recalibration report showing unit has passed. Out of calibration is defined as a device that is not only out of spec on measurement accuracy, but also one that may function properly but has not sustained an up to date calibration certification.

#### **4.5. Critical Interfaces**

A Critical Interface is defined as that particular junction between systems or components which have a specific design characteristic and/or requirement, which are critical to the proper function of the overall LIGO system. If these design requirements or characteristics are not met then there could be an increased likelihood of improper functioning, system failure, and/or damage to itself and/or other attached systems or components. It is the responsibility of the LIGO teams to identify and call out all critical interfaces in the design documents and drawings, and to ensure that appropriate standards of inspection and testing are applied to the systems at these interfaces.

The supplier shall perform levels of inspection as defined by the LIGO teams during the manufacturing and assembly process, including verification to design specifications and (if appropriate) interface tests for fit, function and/or performance. Development and performance of the test plan will be in accordance with the negotiated contract, and the final test plan will be reviewed by the supplier and the LIGO team(s). The supplier shall provide LIGO teams with the results from all tested critical interfaces, and the LIGO team(s) shall work with the supplier to assess the results and review discrepancies and proposed solutions.

#### **4.6. Cleanliness**

All components are to meet cleanliness standards as outlined in the technical documents provided to the vendor. Cleanliness and contamination control will be particularly sensitive with systems and components installed in the vacuum chambers. As part of the bid package, all suppliers of in-vacuum components must include detailed plans for achieving and maintaining cleanliness of manufactured items during the manufacturing process, through the final cleaning process, as well as processes to maintain this state during transport and storage.

#### **4.7. Packaging**

Guidelines shall be developed for packaging to provide sufficient protection for LIGO equipment from the point of manufacture to the delivery at the LIGO observatory sites. Suppliers must ensure that all packaging will meet requirements as defined in the RFP or RFQ, and any deficiencies are reported immediately to LIGO representatives. This includes packaging to protect against environmental, shock, transport noise and vibration, as well as protection from ESD and contamination as required in the negotiated contract or PO. LIGO staff will inspect all packaging upon arrival at a LIGO facility for damage and deficiencies. Note that components and assemblies which have been cleaned for in-vacuum service have special packaging requirements as defined in E960022.

All packaged items shall have appropriate labels attached to properly identify the following:

- Destination Site
- LIGO Subsystem team
- Boldly identify components as clean or environmentally sensitive to prevent opening and contamination in receiving area.
- List any special handling notifications or warnings
- LIGO Contact person and information
- Part ID, serial number or other identifying data
- Shipping manifest with long text description of enclosed items

#### **4.8. Storage**

Supplier shall protect system or components against environmental damage or unauthorized personnel access prior to shipment of finished goods. All items shall be stored with appropriate labeling to ensure removal from storage and transport of item is accurate.

#### **4.9. Transport**

Transport of items to LIGO facilities shall be handled via LIGO approved shipper, and will be insured as directed in the LIGO-Supplier's contract. All critical and/or environmentally sensitive items must be shipped in a manner that will minimize damage in transit. Supplier and shipping company shall utilize proper ride mechanism (air ride or other specific suspension types, isolation techniques, etc), container types and handling methods to protect sensitive items, such as optics and electronics, from vibration, shock pulse, impacts and crushing, as defined by LIGO. Shipping containers and the items they contain shall be properly secured for transport to avoid falling and shuffling of goods internally.

#### **4.10. Customs**

Customs documentation will be filled out appropriately to ensure proper handling, contamination controls and timely throughput while in possession of customs agents. This includes labeling which clearly defines contents, hazards, valuation and contact information. For all customs requirements please contact Rod Luna at Caltech, email [luna\\_r@ligo.caltech.edu](mailto:luna_r@ligo.caltech.edu)

## **5. System Integration and Commissioning Inspection Requirements**

### **5.1. System Integration Inspection Process**

With few exceptions, system installation, integration and commissioning are LIGO Laboratory responsibilities with no supplier involvement. Final inspection shall consist of the following:

- Verification of the product (subsystem or subassembly) against requirements and test parameters identified as requirements in the subsystem documentation.
- Verification of key physical and interface parameters.
- Verification of Configuration.
- Verification of quality of workmanship.
- Verification of a complete set of as-built documentation

### **5.2. System Integration Acceptance Test**

System integrated acceptance testing is a LIGO Laboratory responsibility. Acceptance testing shall be performed after completion of all required operations. LIGO final acceptance testing requirements are as follows:

- Commissioning acceptance testing plans and reports shall be reviewed and approved (and witnessed if possible) by LIGO QA personnel.
- The test shall be performed in accordance with the current version of the appropriate test procedure.
- Instruments and gages used to determine performance characteristics must be within the range of acceptable calibration parameters, including inspection cycles and tested against known standards.
- Tests shall be conducted in the order specified by the test procedure unless otherwise authorized by responsible LIGO engineering personnel.
- Completed test results shall be documented on authorized summary forms or test data sheets.
- Any deviations from the test procedure or discrepancies noted during the conduct of the test shall be documented.
- If appropriate, and to the extent practical, a post-test inspection shall be conducted of the item under test, for the purpose of identifying and recording any changes that may have occurred as a result of the test.



### 6. Advanced LIGO QA Inspection Workflow Chart

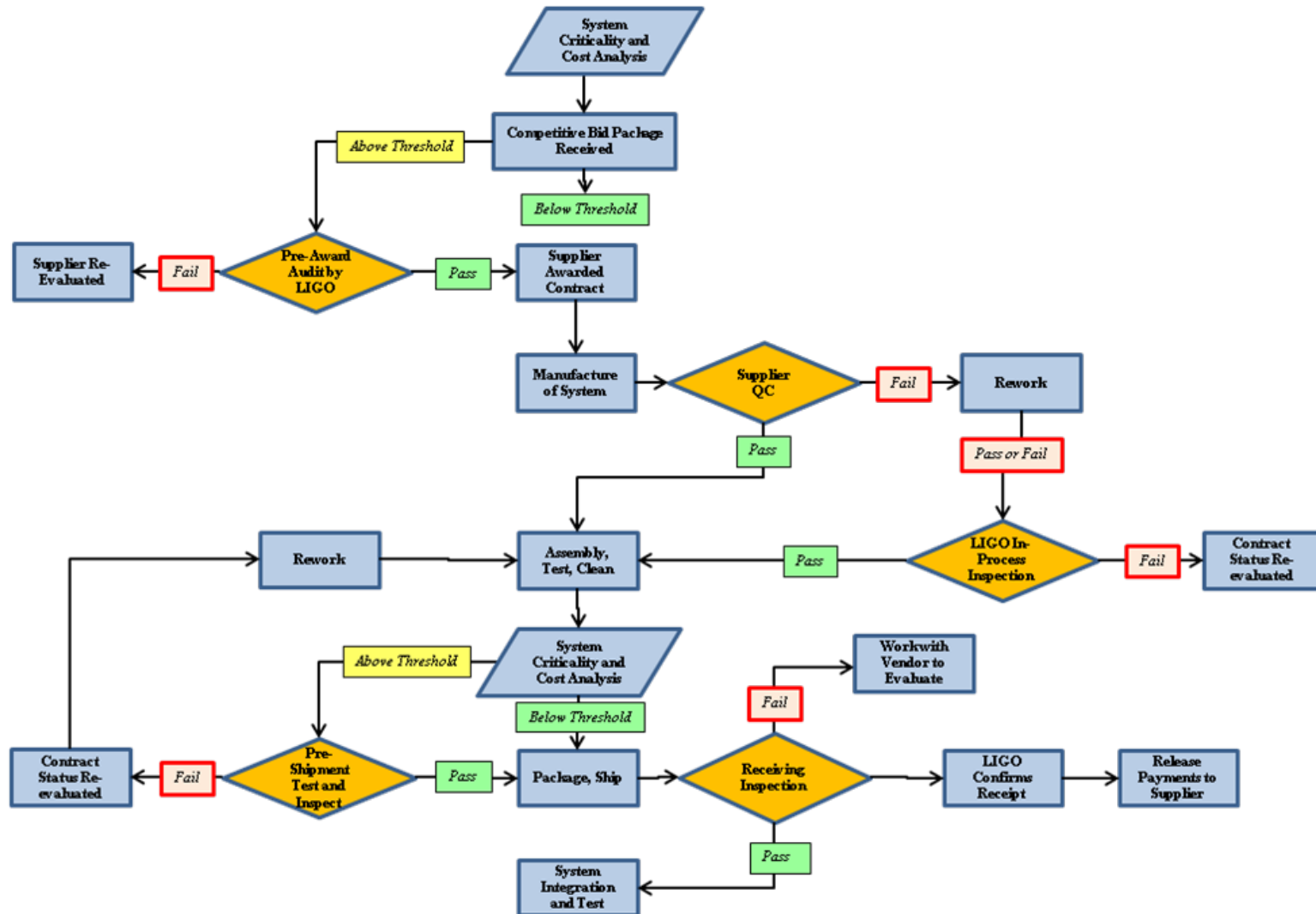



## 7. Glossary

Quality Assurance	QA is defined as a procedure or set of procedures intended to ensure that a product or service under development (before work is complete, as opposed to afterwards) meets specified requirements.
Quality Control	Quality control (QC) is a procedure or set of procedures intended to ensure that a manufactured product or performed service adheres to a defined set of quality criteria or meets the requirements of the client or customer.
System Criticality and Cost Analysis	Evaluation taken place to determine whether a system being manufactured meets the minimum threshold for applying additional inspection criteria. Example: An in vacuum component may not meet minimum cost levels to add a supplier pre-award inspection; however since it is in vacuum it is a critical item that requires added inspections. Determination of criticality and cost thresholds is set by the LIGO teams.
Cost Threshold	A LIGO determined value of a component or system which triggers or precludes an audit or inspection point. LIGO sub-teams will determine this value on a case by case basis, and is evaluated in conjunction with criticality thresholds. In some cases criticality thresholds may require a triggered audit or inspection despite the cost being below a threshold. LIGO has sole determination of these values, however at any time LIGO may require an audit or inspection, and will communicate these to the supplier ahead of time.
Criticality Threshold	A LIGO determined level of importance assigned to a system or component. This assignment is based upon factors including but not limited to duty cycle, installation area, redundancy, availability of spares, lead time to manufacture, etc. LIGO sub-teams are solely responsible for assigning criticality levels to components, and will make the determination for inspections and audits based on criticality independent of cost.
Pre Award Audit	Audit/Inspection by LIGO performed to determine to ability of a supplier to meet to the system or component manufacturing requirements including QA/QC. Safety, capacity, cleanliness, skill and stability.
In Process Inspection	Any inspection that takes place during the manufacturing process. This inspection may be performed by supplier as part of its regular quality control processes, or by LIGO as a spot check of workmanship or as a result of a deficiency in the performance of the supplier or the manufactured component.

Receiving Inspection	<p>Inspection at the LIGO site to verify that goods shipped arrive in good condition, without visible damage, contamination, or other problems that may have been caused during the packaging and shipping process. It is also the point at which LIGO team members look for problems related to improper packaging, as well as missing pieces or cartons. During a Receiving Inspection, LIGO team members will provide an inspection report noting any issues. If shipped item passes inspection it will be moved to the proper storage until its intended use. LIGO members will also submit a passed inspection report which authorizes procurements to release payments to supplier as agreed in contract.</p> <p>If the system does not pass receiving inspection, it will be at the discretion of the LIGO Project on how to handle the issues, which may include returning items to vendor, requiring vendor supported testing and rework, or additional testing at LIGO site before receiving inspection is signed off and payments are released to supplier.</p>
----------------------	--





## **LASER INTERFEROMETER GRAVITATIONAL WAVE OBSERVATORY (LIGO)**

### **COMMERCIAL ITEMS OR SERVICES CONTRACT**

#### **GENERAL PROVISIONS CALIFORNIA INSTITUTE OF TECHNOLOGY "INSTITUTE"**

##### GENERAL PROVISION TITLE

1. Offer and Contract
2. Time of Delivery
3. Improper Delivery
4. Assignment
5. Authority of Institute Representative and Required Notices
6. Changes
7. Force Majeure
8. Existing Commercial Computer Software – Licensing
9. Export Licenses
10. Disputes and Governing Law
11. Inspection and Acceptance
12. Insurance
13. Indemnification
14. New Material
15. Order of Precedence
16. Payment
17. Use of Name
18. Title and Risk of Loss
19. Government Title to Property Purchased or Fabricated with Contract Funds
20. Taxes
21. Termination
22. Warranty
23. Audit and Records
24. Site Visits
25. Nondiscrimination
26. Equal Employment Opportunity
27. Anti-Kickback
28. Clean Air Act and the Federal Water Pollution Contract Act
29. Debarment and Suspension
30. Byrd Anti-Lobbying Amendment
31. Copeland "Anti-Kickback" Act
32. Davis Bacon Act
33. Surety Bonds
34. Rights to Inventions – 37 CFR part 401
35. Patent Rights - Bayh-Dole Act [35 U.S.C. 200 et seq.]

(See Page 2 for Individual General Provision Applicability)

## APPLICABILITY OF INDIVIDUAL GENERAL PROVISIONS

### APPLICABLE TO ALL TRANSACTIONS IN THE UNITED STATES

The term *United States* includes the several States of the United States, the District of Columbia, the Commonwealth of Puerto Rico, the Virgin Islands, American Samoa, Guam, Wake Island, the Canal Zone, and all other territories and possessions of the United States, and the term *States* includes any one of the forgoing.

- |  |  |
|--|--|
| 1. Offer and Contract  | 16. Payment  |
| 2. Time of Delivery  | 17. Use of Name  |
| 3. Improper Delivery   | 18. Title and Risk of Loss   |
| 4. Assignment  | 19. Government Title to Property Purchased or Fabricated with Contract Funds |
| 5. Authority of Institute Representatives and Required Notices | 20. Taxes  |
| 6. Changes   | 21. Termination  |
| 7. Force Majeure   | 22. Warranty   |
| 8. Existing Commercial Computer Software – Licensing           | 23. Audit and Records  |
| 10. Disputes and Governing Law                                 | 24. Site Visits  |
| 11. Inspection and Acceptance                                  | 25. Nondiscrimination  |
| 13. Indemnification  | 26. Equal Employment Opportunity   |
| 14. New Material   | 28. Clean Air Act and the Federal Water Pollution Control Act                |
| 15. Order of Precedence  |  |

### TAXES

20. The applicability of State sales tax is addressed on the face of the Purchase Order  
**[For imports]** Value Added Tax (VAT) is addressed on the face of the Purchase Order

### APPLICABLE IN SPECIAL CIRCUMSTANCES ACCORDING TO THEIR TERMS

9. **[For exports]** Compliance with Export Regulations  
12. **[Suppliers Working on Site]** Insurance  
27. **[For Contracts in excess of \$100,000]** Anti-Kickback Enforcement Act of 1986  
29. **[For Contracts in excess of \$25,000]** Debarment and Suspension  
30. **[For Contracts of \$100,000 or More]** Byrd Anti-Lobbying Amendment  
31. **[For designated Construction/Repair Contracts in excess of \$2,000]** Copeland “Anti-Kickback” Act  
32. **[For designated Construction/Repair Contracts in excess of \$2,000]** Davis-Bacon Act  
33. **[For designated Construction/Repair Contracts in excess of \$500,000]** Surety Bonds  
34. **[For designated Experimental, Development or Research Work]** Rights to Inventions- 37 CFR part 401  
35. **[For designated Experimental, Development or Research Work]** Patent Rights - Bayh-Dole Act [35 U.S.C. 200 et seq.]

### APPLICABLE TO ALL TRANSACTIONS IN THE UNITED STATES

These provisions **do not apply to foreign suppliers** performing outside the United States.

- |                                  |   |
|----------------------------------|---|
| 25. Nondiscrimination            | 32. Clean Air Act and the Federal Water Pollution Control Act |
| 27. Equal Employment Opportunity |   |

This agreement is a subcontract pursuant to an NSF Cooperative Agreement (CA) between the NSF and the Institute, [PHY-0328418](#).

1. **OFFER AND CONTRACT** The following terms, together with such terms, plans, specifications or other documents as attached or incorporated by reference as set forth on the face of this purchase order, constitute the offer of the Institute to Supplier and shall, when accepted, constitute the entire agreement ("Contract") between the Institute and Supplier. Institute hereby gives notice of its objection to any different or additional terms. This Contract is valid only as written. If price, terms, shipping date or other expressed condition of this Contract are not acceptable, the Institute must be notified and any variation must be accepted in writing prior to shipment or delivery. This Contract shall be deemed to have been accepted (a) in the absence of written notification of non-acceptance by the Supplier within a reasonable time, or (b) upon timely delivery of the products identified to the shipping address specified on the face of the order.
2. **TIME OF DELIVERY** Time is of the essence in this Contract. If delivery dates cannot be met, Supplier must notify the Institute immediately. Such notification shall not, however, constitute a change to the terms of this Contract except as the order may be modified in writing by the Institute.
3. **IMPROPER DELIVERY** In addition to other remedies provided by law, the Institute reserves the right to refuse any goods or services and to cancel all or any part of this Contract if Supplier fails to deliver all or any part of the goods or services in accordance with the terms and conditions of this Contract. Acceptance of any part of this order shall not bind the Institute to accept any future shipments nor deprive it of the right to return goods already accepted.
4. **ASSIGNMENT** The Supplier shall have no right to assign this Contract or any benefits from this Contract without prior written consent of the Institute.
5. **AUTHORITY OF INSTITUTE REPRESENTATIVES AND REQUIRED NOTICES; FACSIMILE AND ELECTRONIC SIGNATURES ACCEPTABLE**
  - (a) No order, notice, or direction received by the Supplier and issued pursuant to this Contract shall be binding upon either the Supplier or the Institute, unless issued or ratified in writing by the Institute Purchasing Agent, the Director of Procurement Services, or by representatives designated in writing by either of them.
  - (b) The parties agree that facsimile (fax) or electronic signature copies of contract documents are just as binding as originally-executed documents.
6. **CHANGES** The Institute may at any time, by a written order to the Supplier, make changes within

the general scope of this Contract in any one or more of the following: (a) drawings, designs, or specifications; (b) method of shipment or packing; and (c) time or place of delivery. If any such change causes an increase or decrease in the cost of, or the time required for, the performance of any part of the work under this order, an equitable adjustment may be made in the order price or delivery schedule or both, and the order shall be modified in writing accordingly. Any claim by Supplier for adjustment under this Article must be asserted within 30 days from the date of receipt by Supplier of the notification of change; provided, however, that the Institute, if it decides that the facts justify such action, may receive and act upon any such claim asserted at any time prior to final payment under this purchase order. Nothing in this clause shall excuse Supplier from proceeding with this order as changed.

7. **FORCE MAJEURE** Each party shall not be liable for damages arising out of either its failure to deliver or any delay in delivery caused by strikes, lockouts, fires, war, or acts of God. The Supplier shall notify the Institute in writing as soon as it is reasonably possible after the commencement of any event triggering a delayed delivery or inability to deliver.
8. **EXISTING COMMERCIAL COMPUTER SOFTWARE – LICENSING** (This Article is applicable to the acquisition of any existing commercial computer software under this Contract.)
  - a) Where the Supplier proposes its standard commercial software license, only those applicable portions that comply with the provisions of this Contract are incorporated into and made a part of this Contract.
  - (b) If the Supplier does not propose its standard commercial software license until after this Contract has been issued, or at or after the time the computer software is delivered, such license shall nevertheless be deemed incorporated into and made a part of this Contract under the same terms and conditions as in paragraph (a) above. For purposes of receiving updates, correction notices, consultation, and similar activities on the computer software, any authorized user may acknowledge receipt of a registration form or card and return it directly to the Supplier; however, such signing shall not add to or alter any of the terms and conditions of this Contract.
  - (c) If the specified computer software is shipped or delivered to the Institute, it shall be understood that the Supplier has unconditionally accepted the terms and conditions set forth in this Article, and that the terms and conditions of this Contract (including the incorporated license) constitute the entire agreement between the parties concerning rights in the computer software.
  - (d) Supplier understands and agrees that the computer software may be: (1)

Used, or copied for use, in or with any computer owned or leased by, or on behalf of the Institute provided that the software is not used, nor copied for use, in or with more than one computer simultaneously, unless otherwise permitted; (2) Reproduced for safekeeping (archives) or backup purposes; (3) Modified, adapted, or combined with other computer software, provided that the modified, combined, or adapted portions of the derivative software incorporating restricted computer software shall be subject to the same restricted rights; and (4) Disclosed and reproduced for use by Institute designees in accordance with this Article. (e) Supplier agrees that the software may be used by the Institute in support and furtherance of any of its obligations to the US Government or other funding organization. (f) Supplier warrants that it has the right to sell, license, or transfer the license for the software furnished to the Institute under this Contract in accordance with the terms of this Contract.

9. **EXPORT LICENSES** The Supplier shall comply with all U.S. export control laws and regulations, including the International Traffic in Arms Regulations (ITAR), 22 CFR Parts 120 through 130, and the Export Administration Regulations (EAR), 15 CFR Parts 730 through 799, in the performance of this Contract. In the absence of available license exemptions/exceptions, the Supplier shall be responsible for obtaining the appropriate licenses or other approvals, if required, for exports of hardware, technical data, and software, or for the provision of technical assistance.

10. **DISPUTES AND GOVERNING LAW** (a) Any dispute or claim arising out of, in connection with, or relating to this Contract shall be submitted for resolution to ascending levels of management of the parties. If the dispute cannot be resolved after such negotiations, either party may pursue any appropriate legal recourse not inconsistent with the provisions of this Contract. (b) Pending any decision, appeal or judgment or the settlement of any dispute, Supplier agrees to proceed diligently with the performance of the requirements of this Contract. (c) This Contract shall be construed and enforced in accordance with the laws of the State of California. Disputes will be adjudicated in Los Angeles, California.

11. **INSPECTION AND ACCEPTANCE** The Institute shall have the right to inspect the work and activities of the Supplier under this Contract in such manner and at all reasonable times as are deemed appropriate. Final inspection shall be at the Institute's premises unless otherwise agreed in writing. The Institute, at its option, may reject any non-conforming items and (i) return such non-conforming items to the Supplier at the Supplier's

risk and expense for credit to the Institute at the full invoice price plus all transportation and other related costs, or (ii) hold them for disposition in accordance with the Supplier's instructions at the Supplier's expense, including storage and handling. If the Institute rejects items as nonconforming, the quantities under this Contract will automatically be reduced unless the Institute otherwise notifies the Supplier. The Supplier will not replace quantities so reduced without written instruction by the Institute. Payment for nonconforming goods shall not constitute an acceptance thereof, limit, or impair the Institute's right to assert any legal or equitable remedy, or relieve the Supplier's responsibility for latent defects. The Institute may also opt for a refund of the amount paid under this Contract.

12. **INSURANCE** (This Article is applicable when the Supplier will be entering Institute-controlled premises.) (a) The Supplier shall, at its own expense, provide and maintain during the entire performance period of this Contract at least the following types and minimum amounts of insurance with the Institute named as an additional insured in policies for comprehensive liability insurance with a licensed carrier authorized to do business in the State of California: (1) Workers' Compensation and Employer's Liability Insurance, as required by applicable Federal and State workers' compensation and occupational disease statutes. The Employer's Liability coverage shall be at least \$100,000, except in states with exclusive or monopolistic funds that do not permit worker's compensation to be written by private carriers. (2) Comprehensive Liability Insurance, including automobiles (owned, non-owned, or leased), completed operations, products, and contractual liability, for a combined single limit of not less than \$1,000,000 for all deaths, injuries, and property damage arising from one accident or occurrence. (b) Insurance Certificates and Endorsements. Before commencing work under this Contract, the Supplier shall furnish (i) certificates of insurance for the coverages specified in paragraph (a) above, and (ii) an additional insured endorsement naming the Institute as an additional insured to the Contract for the coverage specified above. Such certificates and the endorsement shall provide that any cancellation or material change in the insurance policies shall not be effective (i) for such period as the laws of the State in which this Contract is to be performed, or (ii) until 30 days after the insurer or the Supplier gives written notice to the Institute, whichever period is longer. Also, such certificates and the endorsement shall (i) cover contractual liability assumed under this Contract, and (ii) be primary and noncontributing to any insurance procured by the Institute. The Supplier agrees to

permit the Institute to examine its original policies, should the Institute so request. Should the Supplier at any time neglect or refuse to provide the insurance required herein, or should such insurance be canceled, the Institute shall have the right to procure same and the costs thereof shall be deducted from monies then due or thereafter to become due to the Supplier.

13. **INDEMNIFICATION** The Supplier agrees to defend, indemnify and hold harmless the Institute from and against all claims, liability and expenses, including reasonable legal fees, arising from any actual or claimed: (i) injury to any person or property resulting from any act or omission of Supplier, its employees or agents, excepting such liability as may result solely from the negligent acts or omissions of the Institute or its employees; and (ii) infringement of any patent, copyright, or trademark by reason of the sale or use of the goods provided by Supplier hereunder. The Supplier's obligations hereunder shall survive acceptance of the goods and payment thereof by the Institute.
14. **NEW MATERIAL** Unless this Contract specifies otherwise, the Supplier represents that the supplies are new and are not of such age or so deteriorated as to impair their usefulness or safety. If the Supplier believes that furnishing other than new material will be in the Institute's interest, the Supplier shall so notify the Purchasing Agent in writing and request authority to use such material.
15. **ORDER OF PRECEDENCE** To the extent there is inconsistency among any documents relating to this order, the inconsistency will be resolved in the following order of priority: (a) These General Provisions; (b) The details specified on the order, or description of products or services; (c) any other documents the Institute agrees in writing to incorporate by reference.
16. **PAYMENT** (a) Invoices shall be submitted in duplicate to the attention of the Institute's Accounts Payable Department, unless otherwise specified, and shall contain the following information as applicable: (i) Contract number, (ii) item number, (iii) description of supplies or services, (iv) size, (v) quantity, (vi) unit price, (vii) extended totals and (viii) any other information which may be specified on the face of this Contract. Any applicable state sales or use taxes or Federal excise taxes shall be shown separately on the invoice. (b) The Institute shall pay the Supplier, upon the submission of proper invoices, the prices stipulated in this Contract for supplies delivered and accepted or services rendered and accepted, less any deductions provided in this Contract. (c) The Institute shall make its best effort to make payments within the net period, if any, specified in the Contract, measured from the date of receipt of

the goods or services at the destination or the date of receipt of the invoice, whichever is later. Discount time periods will be measured from the same date. Payment shall be deemed to have been made on the date the check is mailed or on the date on which an electronic funds transfer was made. In no event will the Institute be liable for or pay a surcharge, interest, or any kind of penalty as a result of the Institute's payment not being made within the net period, if any, specified in the Contract or the date of payment by electronic funds transfer. (d) Payment for goods or services in accordance with this paragraph will not waive or otherwise affect the right of the Institute to inspect such goods or services or to reject, or revoke acceptance of, nonconforming goods.

17. **USE OF NAME** Supplier agrees not to use the name or trademarks of the Institute or any member its staff in sales promotional work or advertising, or in any form of publicity, without the prior written permission of the Institute.
18. **TITLE AND RISK OF LOSS** (a) Unless otherwise provided in Section 19 or elsewhere in this Contract, title to tangible property (property of any kind except intangible property and debt instruments) furnished under this Contract shall pass to the Institute upon formal acceptance by the Institute, regardless of when or where the Institute takes physical possession, unless the Contract specifically provides for earlier passage of title. (b) Risk of loss shall not pass to the Institute until the tangible property called for in this Contract has been actually received and accepted by the Institute at the destination specified. Supplier assumes all responsibility for packing, crating, marking, transportation and liability for loss or damage in transit, notwithstanding any agreement by Institute to pay freight, express or other transportation charges. Supplier agrees to trace lost or delayed shipments at the request of the Institute.
19. **GOVERNMENT TITLE TO PROPERTY PURCHASED OR FABRICATED WITH CONTRACT FUNDS** Title to tangible property shall vest in the Government upon acquisition when the tangible property is intended to be installed at, incorporated into, built, or necessary for the construction or operation of either the Hanford or Livingston Observatories. All Government property acquired in accordance with this Section 19 shall be subject to the requirements set forth below:
  1. Title.

(a) Tangible Property means property of any kind except intangible property and debt instruments. Title to all tangible property procured with funds provided through this Contract, and subject to this Section 19, shall vest in the Government as follows:

1) If this Contract contains a provision directing the Supplier to purchase material which the Government will reimburse as a direct item of cost under the Institute's primary Award, title to property shall pass to and vest in the Government upon delivery of such property to the Government, to the Institute, to the Supplier, to any subcontractor, or to any agent of the Government, of the Supplier, or of any subcontractor; and

2) Title to all other property shall pass to and vest in the Government upon the earliest to occur of the following:

(i) issuance of the property for use in contract performance pursuant to this Contract;

(ii) commencement of processing of the property or its use in contract performance pursuant to this Contract; or

(iii) reimbursement of the cost of the property by the Institute on behalf of the Government.

2. Legal title to all tangible property furnished by the NSF or acquired from other Government agencies shall remain with the Government, unless otherwise specified in this Contract.

3. Title to Government property shall not be affected by the incorporation or attachment thereof to any property not owned by the Government, nor shall any Government property lose its identity by reason of affixation to any realty.

4. All subcontracts issued or awarded with respect to the performance of this Contract shall include provisions regarding the determination of title to tangible property acquired by the subcontractor in accordance with Sections 18 and 19.

5. Should Supplier purchase tangible property pursuant to this Contract and subject to this Section 19, Supplier shall be a limited agent of the NSF solely for the purpose of transferring and vesting title to such tangible property in the Federal Government. The agent shall be solely responsible for the payment of the purchase price of tangible property acquired, and the agent shall have no authority to bind or obligate the Institute, NSF or the Federal Government for payment of the purchase price to any third party. Such agents shall be and shall remain liable for the risk of loss of, destruction of, or damage to tangible property acquired until such tangible property is transferred to the possession of the Government or acceptance by the Institute.

20. **TAXES** (a) **Except as may be otherwise provided on this order**, the contract price includes all applicable Federal, State, and local taxes and duties. With respect to transactions for which the

Institute may be exempt from any tax or duty, the Institute will provide, upon request, evidence to support its claim to such exemption. (b) The Institute will comply with all Federal and State income tax laws with respect to withholding and year-end tax reporting. (c) The Internal Revenue Service (IRS) requires the Institute to have on file a Taxpayer Identification Number (TIN) for every US person or US business that receives a payment, regardless if the payment is tax reportable or not. This information is provided on IRS Form W-9. US Citizens and Resident Aliens are required to complete a Form W-9 before receiving any payments from the Institute. A TIN can be any of the following: a Social Security Number (SSN) an Individual Taxpayer Identification Number (ITIN) or an Employer Identification Number (EIN). Failure to provide a TIN will result in delay of payment and/or backup withholding. (d) Foreign businesses providing services in the US for the Institute are required to provide the appropriate IRS Form W-8 (i.e., Form W-8BEN, W-8ECI, or W-8IMY). (e) Foreign individuals providing services in the US for the Institute are required to provide an IRS Form W-8BEN or IRS Form 8233 depending on the appropriate tax withholding treatment.

21. **TERMINATION** (a) **For Cause.** The Institute may terminate this Contract, or any part of it, for cause in the event of any default by the Supplier, or if the Supplier fails to comply with any Contract terms and conditions, or fails to provide the Institute, upon request, with adequate assurances of future performance. In the event of termination for cause, the Institute shall not be liable to the Supplier for any amount for supplies or services not accepted, and the Supplier shall be liable to the Institute for any and all rights and remedies provided by law. If it is determined that the Institute improperly terminated this Contract for cause, such termination shall be deemed a termination for convenience. (b) **For Convenience.** The Institute reserves the right to terminate this Contract, or any part hereof, for its sole convenience. In the event of such termination, the Supplier shall immediately stop all work hereunder and shall immediately cause any and all of its subcontractors to cease work. Subject to the terms of this Contract, the Supplier shall be paid a percentage of the Contract price reflecting the percentage of the work performed prior to the notice of termination, plus reasonable charges the Supplier can demonstrate to the satisfaction of the Institute, using its standard record keeping system, have resulted from the termination. The Supplier shall not be paid for any work performed or costs incurred which reasonably could have been avoided.

22. **WARRANTY** Supplier expressly warrants all goods and services delivered under this Contract to be free from defects in material and workmanship and to be of the quality, size and dimensions ordered. This express warranty shall not be waived by reason of the acceptance of the goods or services or payment by Institute. The Supplier shall provide the Institute with a copy of any standard warranty which is normally offered on a commercial product deliverable under this Contract. The commercial product warranty shall be deemed to be incorporated by reference and the Institute shall be entitled to all rights under such warranty.
23. **AUDIT AND RECORDS** Financial records, supporting documents, statistical records, and other records pertinent to this Contract shall be retained by the Supplier for a period of five years from acceptance by the Institute. Supplier agrees that the Institute, the National Science Foundation, the Comptroller General of the United States, or any of their duly authorized representatives, shall have access to any books, documents, papers and records of the Supplier which are directly pertinent to this Contract, for the purpose of making audits, examinations, excerpts and transcriptions.
24. **SITE VISITS** NSF and the Institute, through authorized representatives, have the right, at all reasonable times, to make site visits to review project accomplishments and management control systems and to provide such technical assistance as may be required. If any site visit is made by NSF or the Institute on the premises of the Supplier or a contractor under a subcontract, the Supplier shall provide and shall require its contractors to provide all reasonable facilities and assistance for the safety and convenience of the Institute or Government representatives in the performance of their duties. All site visits and evaluations shall be performed in such a manner that will not unduly delay the work.
25. **NONDISCRIMINATION** The Contract is subject to the provisions of Title VI of the Civil Rights Act of 1964 [42 U.S.C. § 2000d], Title IX of the Education Amendments of 1972 [20 USC §§ 1681 et seq.], the Rehabilitation Act of 1973 [29 U.S.C. § 794], the Age Discrimination Act of 1975 [42 U.S.C. §§ 6101 et seq], and all regulations and policies issued by NSF pursuant to these statutes. In accordance with these statutes, regulations, and policies, no person on the basis of race, color, national origin, sex, disability, or age shall be excluded from participation in, be denied the benefits of, or otherwise be subjected to discrimination under the Contract.
26. **EQUAL EMPLOYMENT OPPORTUNITY** This Contract is subject to the requirements of Executive Orders 11246 and 11375 and the rules and regulations or the Secretary of Labor (41 CFR Chapter 60) in promoting Equal Employment Opportunities.
27. **ANTI-KICKBACK ENFORCEMENT ACT OF 1986** This Contract is subject to the provisions of the Anti-Kickback Enforcement Act of 1986, Public Law 99-634 (41 U.S.C. 51-58). By accepting this order, Seller certifies that it has not paid kickbacks directly or indirectly to any Institute employee for the purpose of obtaining this or any other Institute purchase order or to obtain favorable treatment in an Institute matter.
28. **CLEAN AIR ACT AND THE FEDERAL WATER POLLUTION CONTROL ACT** – Should this Contract be for an amount in excess of \$100,000, Supplier agrees to comply with all applicable standards, orders or regulations issued pursuant to the Clean Air Act (42 U.S.C. 7401 et seq.) and the Federal Water Pollution Control Act as amended (33 U.S.C. 1251 et seq.). Further, Supplier agrees as follows:
- To comply with all the requirements of Section 114 of the Clean Air Act [42 U.S.C. §7414] and Section 308 of the Clean Water Act [33 U.S.C. § 1318], respectively, relating to inspection, monitoring, entry, reports and information, as well as other requirements specified in Section 114 and Section 308 of the Clean Air Act and the Clean Water Act, respectively, and all regulations and guidelines issued thereunder before the Contract.
  - That no portion of the work required by the Contract will be performed in a facility listed on the Environmental Protection Agency List of Violating Facilities on the date that the Contract was awarded unless and until EPA eliminates the name of such facility or facilities from such listing.
  - To use its best efforts to comply with clean air standards and clean water standards at the facility in which the Contract is being performed.
  - To insert the substance of the provisions of this article into any nonexempt subcontract.
29. **DEBARMENT AND SUSPENSION** – (a) Supplier shall fully comply with the requirements stipulated in 2 CFR Part 180, as modified by 45 CFR 620.330 and shall ensure that any lower tier covered transaction, as described in 2 CFR 180.220 and modified by 45 CFR 620.200 and 620.220 includes a term or condition requiring compliance with these requirements. The Supplier acknowledges that failing to disclose the information required under 45 CFR § 620.335 may result in the termination of the Contract, or pursuance of other available remedies, including suspension and debarment. Supplier may access the Excluded Parties List System at <http://epls.arnet.gov>. (b) No contract at any tier shall be made to parties listed on the General Services Administration's List

of Parties Excluded from Federal Procurement or Nonprocurement Programs in accordance with E.O.s 12549 and 12689, "Debarment and Suspension." This list contains the names of parties debarred, suspended, or otherwise excluded by agencies, and contractors declared ineligible under statutory or regulatory authority other than E.O. 12549. Supplier, whose Contract exceeds the small purchase threshold, shall provide the required certification regarding its exclusion status and that of its principal employees.

30. **[FOR CONTRACTS OF \$100,000 OR MORE] BYRD ANTI-LOBBYING AMENDMENT** - Supplier warrants that Supplier has applied or bid on a Contract of \$100,000 or more and has filed the required certification. Each subcontracting tier must certify to the tier above that it will not and has not used Federal appropriated funds to pay any person or organization for influencing or attempting to influence an officer or employee of any agency, a member of Congress, officer or employee of Congress, or an employee of a member of Congress in connection with obtaining any Federal contract, grant or any other award covered by 31 U.S.C. 1352. Each tier shall also disclose any lobbying with non-Federal funds that takes place in connection with obtaining any Federal award. Such disclosures are forwarded from tier to tier up to the recipient.
31. **[FOR CONSTRUCTION/REPAIR CONTRACTS >\$2000] Copeland "Anti-Kickback" Act (18 U.S.C. 874 and 40 U.S.C. 276c)** Supplier shall comply with the Copeland "Anti-Kickback" Act (18 U.S.C. 874), as supplemented by Department of Labor regulations (29 CFR part 3, "Contractors and Subcontractors on Public Building or Public Work Financed in Whole or in Part by Loans or Grants from the United States").
32. **[FOR CONSTRUCTION/REPAIR CONTRACTS >\$2000] Davis-Bacon Act, as amended (40 U.S.C. 276a to a-7)** Supplier shall comply with the Davis-Bacon Act (40 U.S.C. 276a to a-7) and as supplemented by Department of Labor regulations (29 CFR part 5, "Labor Standards Provisions Applicable to Contracts Governing Federally Financed and Assisted Construction").
33. **[FOR CONSTRUCTION/REPAIR CONTRACTS >\$500,000] Surety Bonds - If so directed**, the Supplier shall furnish separate bid guarantees, performance and payment bonds to the Institute. Each bond shall set forth a penal sum in an amount not less than the Contract Price. Each bond furnished by the Supplier shall incorporate by reference the terms of this Contract as fully as though they were set forth verbatim in such bonds. In the event the Contract Price is adjusted by Change Order executed by the Contractor, the

penal sum of both the performance bond and the payment bond shall be deemed increased by like amount. The performance and payment bonds furnished by the Supplier shall be in form suitable to Institute and shall be executed by a surety, or sureties, reasonably acceptable to the Institute.

34. **[For designated Experimental, Development or Research Work] Rights to Inventions** - For non-profit organizations and small business firms, patent rights shall be governed by 37 CFR part 401, titled "Rights to Inventions Made by Non-Profit Organizations and Small Business Firms under Government Grants, Contracts and Cooperative Agreements".
35. **[For designated Experimental, Development or Research Work] Patent Rights** – Bayh-Dole Act [35 U.S.C. 200 et seq.]



## Embedded Adobe XML Form

The file [https://dcc.ligo.org/public/0000/F0810001/004/Technical\\_Direction\\_Memo\\_template\\_F0810001-v4.pdf](https://dcc.ligo.org/public/0000/F0810001/004/Technical_Direction_Memo_template_F0810001-v4.pdf) is an Adobe XML Form document that has been embedded in this document. Double click the pushpin to view.



- NOTES CONTINUED:**
- ⑤ SCRIBE, ENGRAVE, OR MECHANICALLY STAMP (NO INKS OR DYES) DRAWING PART NUMBER, REVISION (AND VARIANT OR TYPE IF APPLICABLE) ON NOTED SURFACE OF PART FOLLOWED ON THE NEXT LINE WITH A THREE DIGIT SERIAL NUMBER. SERIAL NUMBERS START AT 001 FOR THE FIRST ARTICLE AND PROCEED CONSECUTIVELY. USE MINIMUM 0.12" HIGH CHARACTERS, UNLESS THE SIZE OF THE PART DICTATES SMALLER CHARACTERS. A VIBRATORY TOOL MAY BE USED. EXAMPLE: DXXXXXX-VY, TYPE-XX, S/N XXX
  - ⑥ AFTER COMPLETION OF THE WELDMENT, MACHINE AT TOP OF ITEM 3 TO NOTED SPECIFICATIONS IF NECESSARY. LEVEL THE UPPER FACE OF ITEM 3 (SQUARE WITH MACHINING HEAD) BEFORE MACHINING.
  - ⑦ FASTEN ITEMS 2 TO D1000434 FOOTING BEFORE APPLYING NOTED WELDS, TO ENSURE ALIGNMENT. FOR EACH ITEM 2, USE THREE 1/2-20 UNF SCREWS TO TAPPED HOLES IN FOOTING. FOOTING MUST BE REMOVABLE & RE-ATTACHABLE POST-WELD, WITH NO BINDING OF SCREWS. TO BE DELIVERED WITH FOOTING ATTACHED.
  - ⑧ WARPAGE OF ITEMS 2, 3, & FOOTING TO BE MINIMIZED USING PREFERRED METHODS, IE. HEAT SINKING.

REV.	DATE	DCN #	DRAWING TREE #
v1	05 AUGUST 2010	E1000182-v1	-
v2	15 OCT 2010	E1000182-v2	-
-	-	-	-

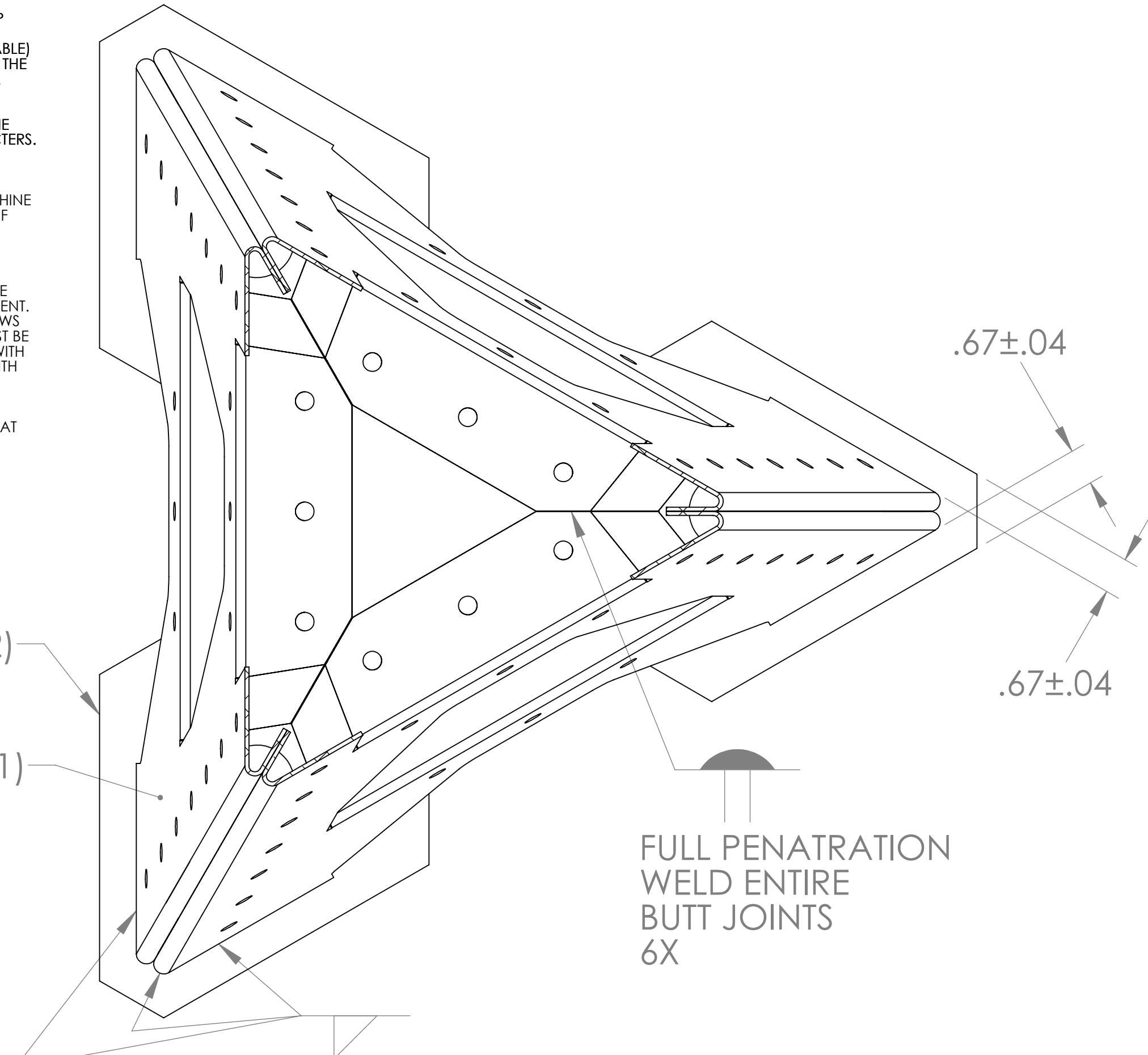

FILLET WELD ALL ITEM 1 / ITEM 2 INTERFACES (OUTSIDE ONLY) ALL THREE LOCATIONS

⑦ ⑧

**SECTION A-A**

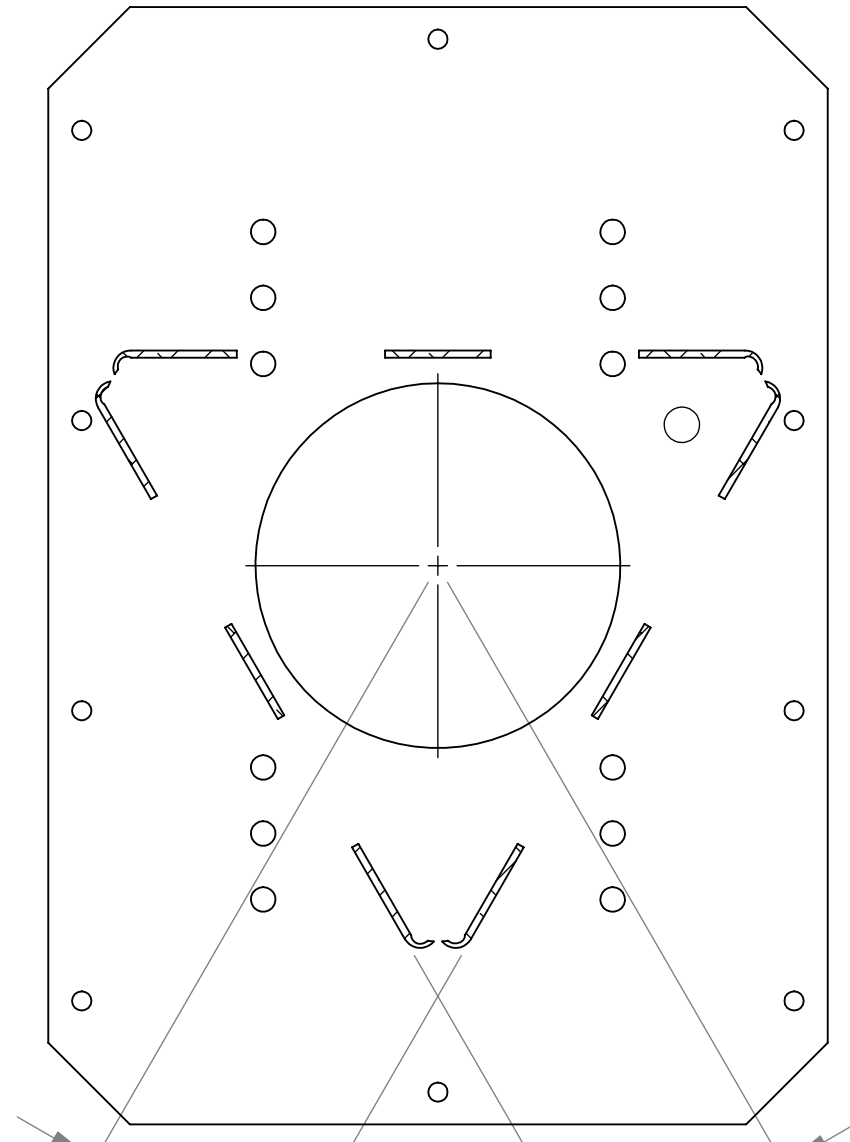

**SECTION B-B  
SCALE 1 : 2**

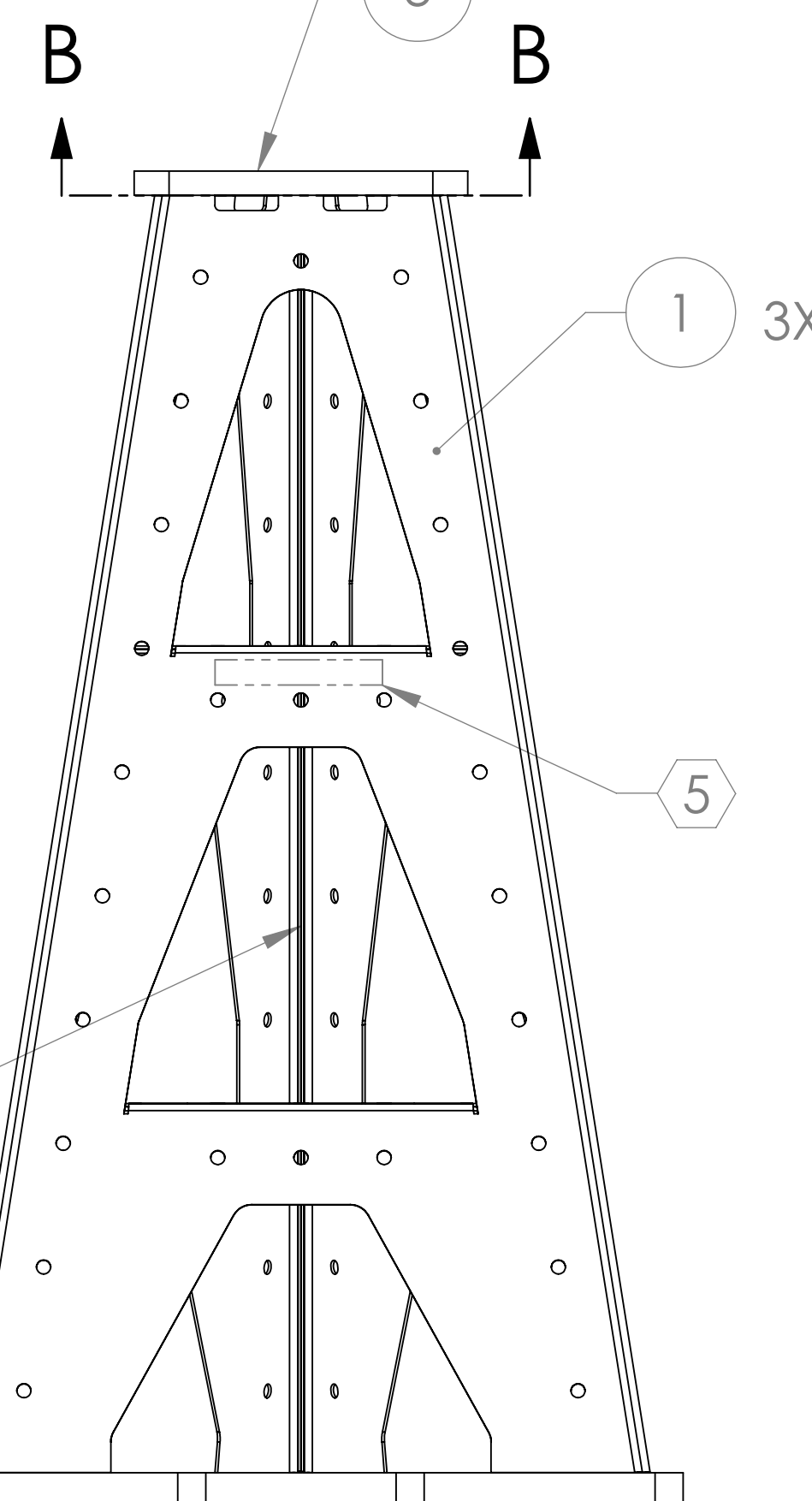
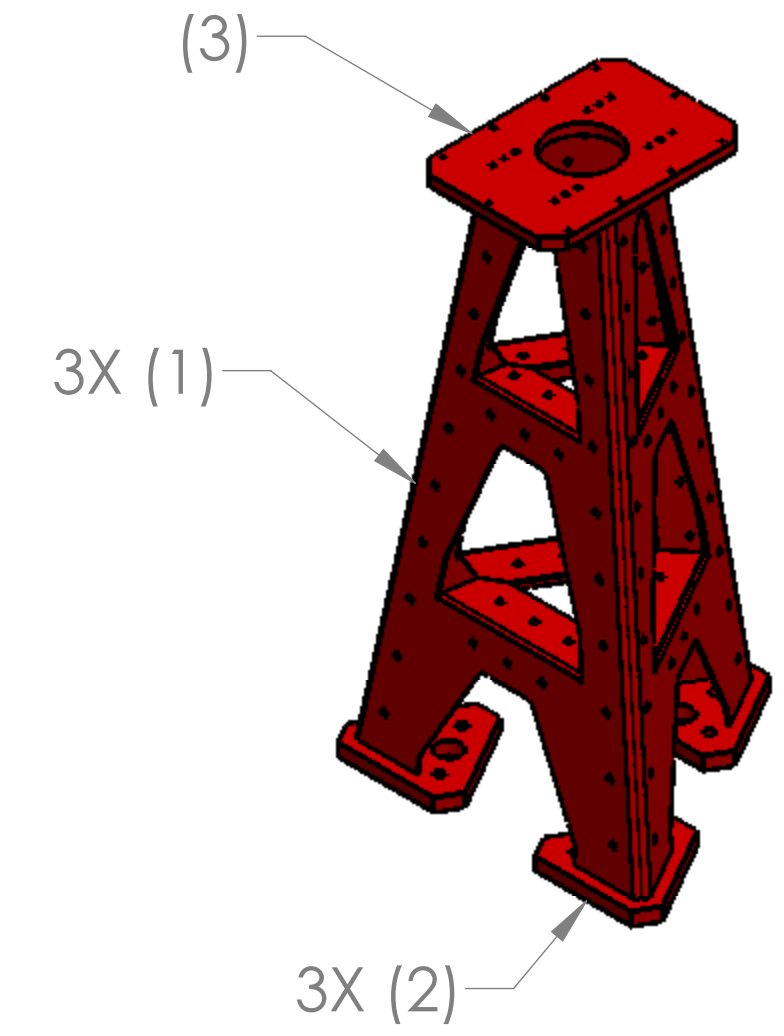
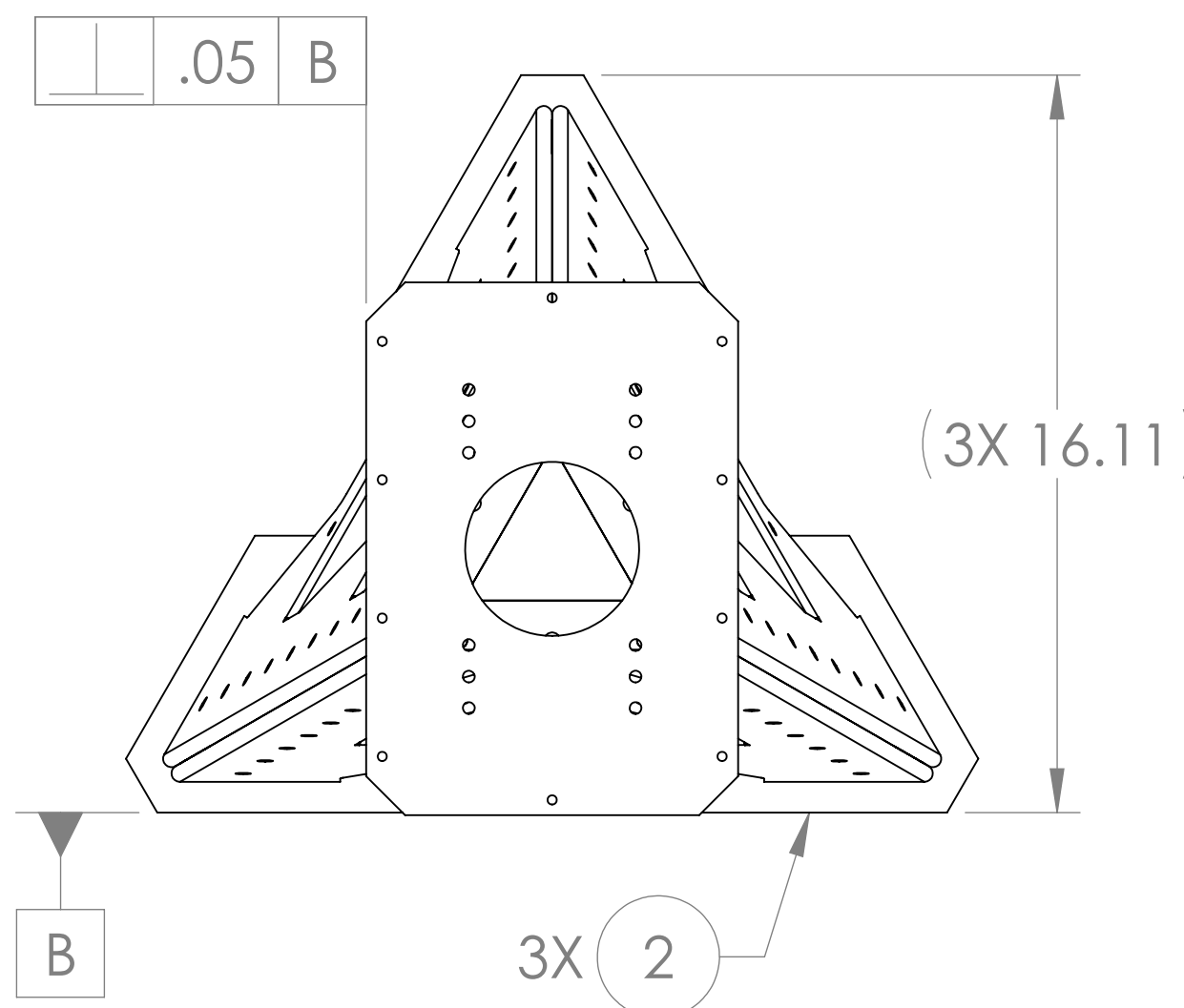

1-2  
3/8-2  
INCLUDE ENDS

FILLET WELD ALL ITEM 1 / ITEM 3 INTERFACES (OUTSIDE ONLY) ALL THREE LOCATIONS

⑧

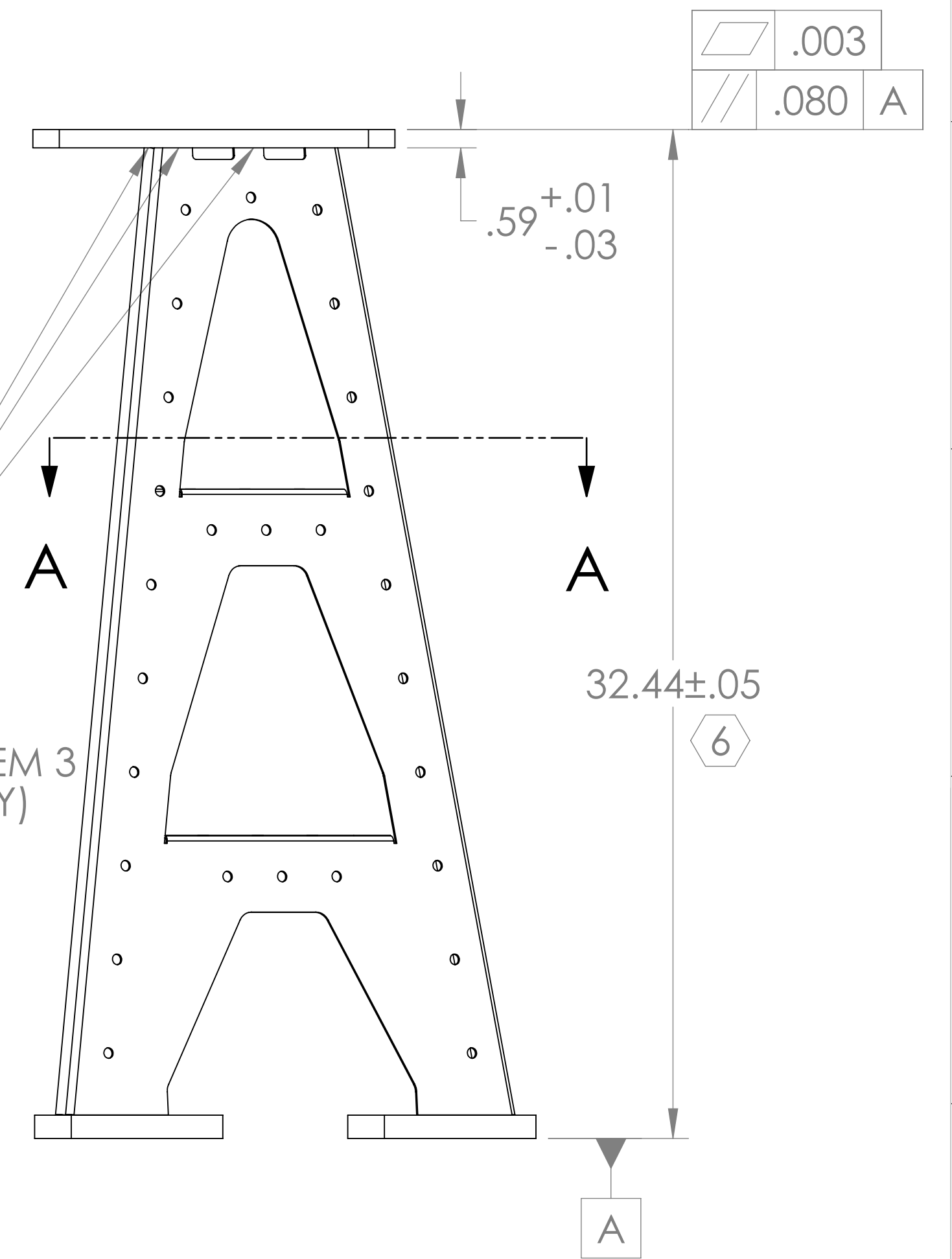

NOTES AND TOLERANCES: (UNLESS OTHERWISE SPECIFIED)	
DIMENSIONS ARE IN INCHES	
TOLERANCES: .XX ± N/A .XXX ± N/A	
ANGULAR ± N/A°	
MATERIAL	FINISH
N/A	N/A μinch

**LIGO** CALIFORNIA INSTITUTE OF TECHNOLOGY  
MASSACHUSETTS INSTITUTE OF TECHNOLOGY

SYSTEM: **ADVANCED LIGO** SUB-SYSTEM: **AOS**

NEXT ASSY: **D1001335 D1001339**

ITEM NO.	PART NUMBER	DESCRIPTION	MATERIAL	REQ	SPARE	TOTAL
3	D1000425	ALIGO AOS OPLEV TX PIER TABLE (TM)	304 SSSL	1		1
2	D1000426	ALIGO AOS PIER BASE I	304 SSSL	3		3
1	D1001655	ALIGO AOS OPLEV TX PIER SIDE PANEL (TM-LLO)	304 SSSL	3		3

**PART NAME**  
**ALIGO AOS OPLEV TX PIER WELDMENT (TM)**

DESIGNER: C. CONLEY 25 JUN 2010  
DRAFTER: N. KILPATRICK 24 MAY 2010  
CHECKER:  
APPROVAL:

SIZE: **D** DWG. NO.: **D1000452** REV.: **v2**

SCALE: 1:4 PROJECTION: SHEET 1 OF 1

D1000452.dwg: AOS Oplev TX Pier Weldment (TM), PART PDM REV: X-000, DRAWING PDM REV: X-011

NOTES CONTINUED:  
 (1) STOCK FINISH / AS RECEIVED.

REV.	DATE	DCN #	DRAWING TREE #
v1	27 MAY 2010	E1000182-v1	-
-	-	-	-
-	-	-	-

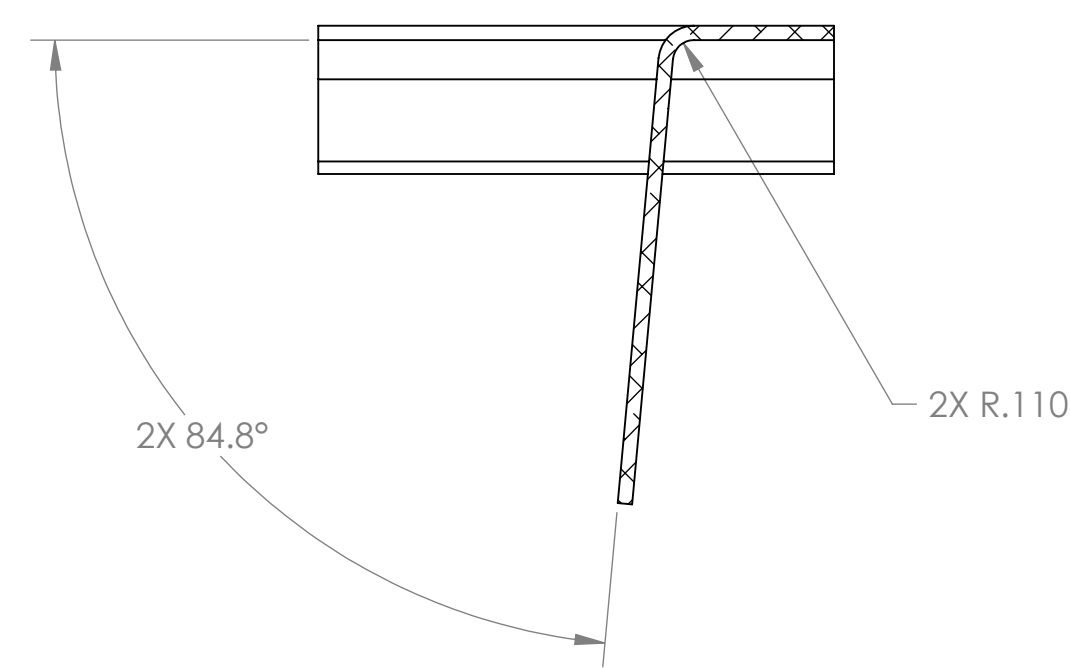

**SECTION A-A  
SCALE 1 : 1**

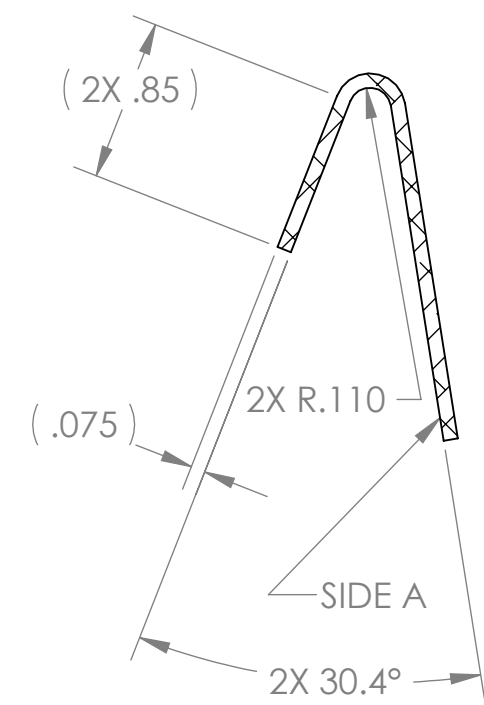

**SECTION B-B  
SCALE 1 : 1**

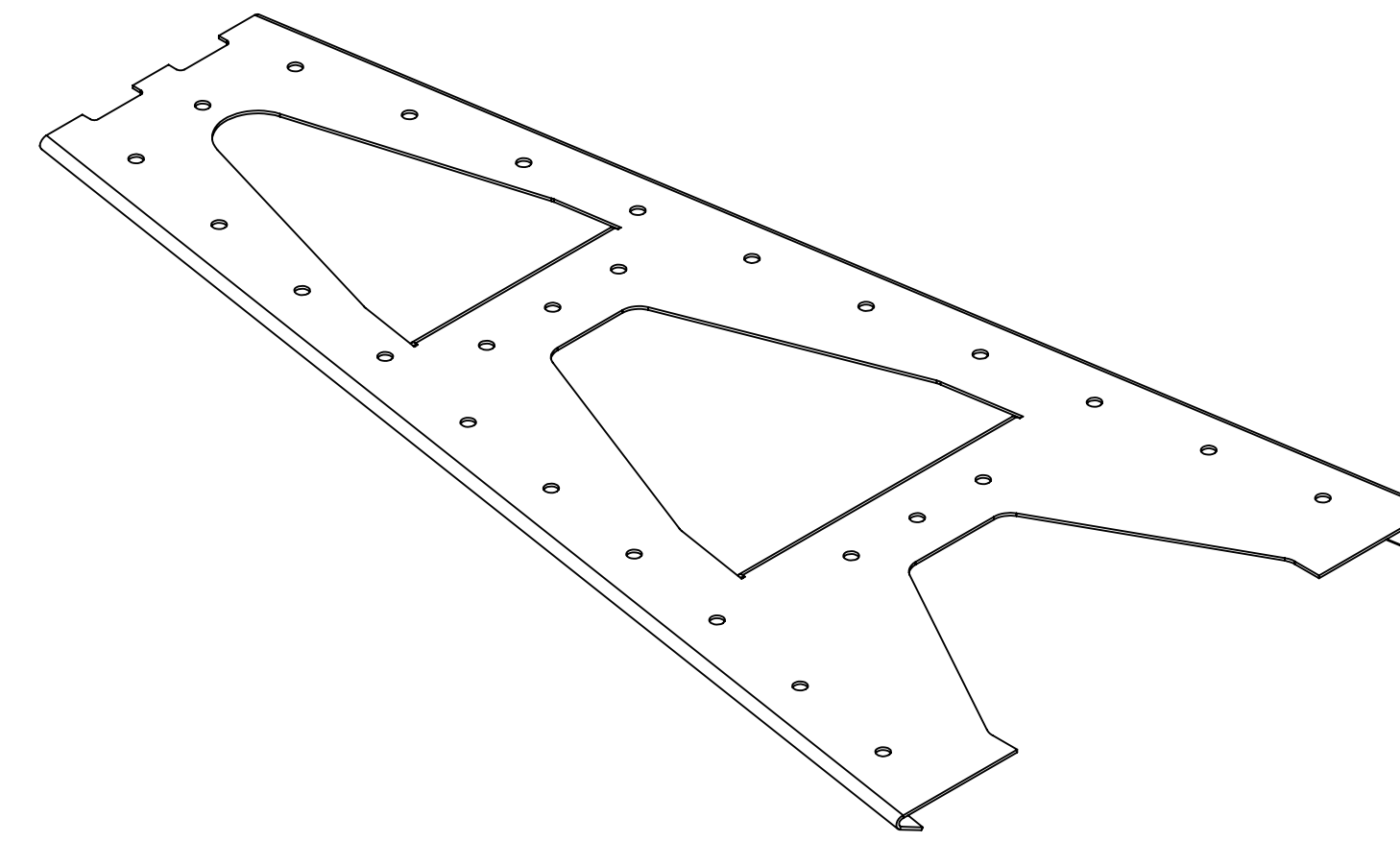

**ISO VIEW**

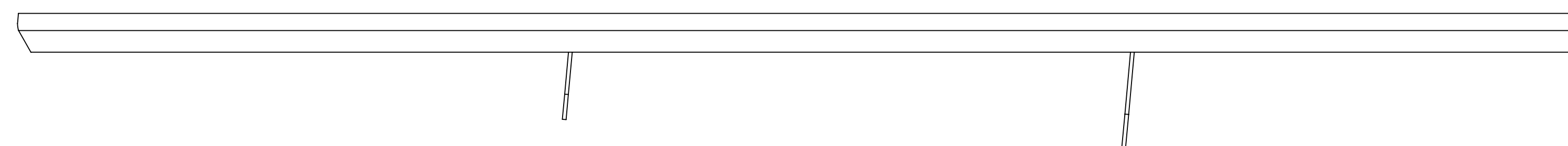
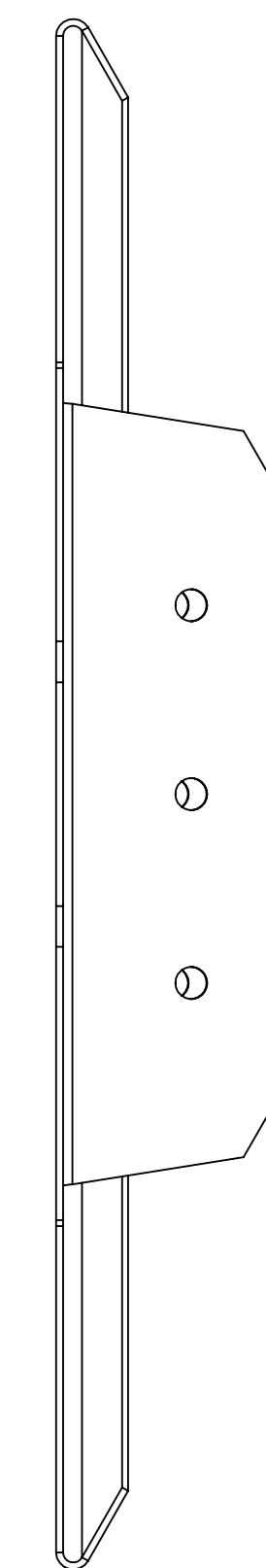
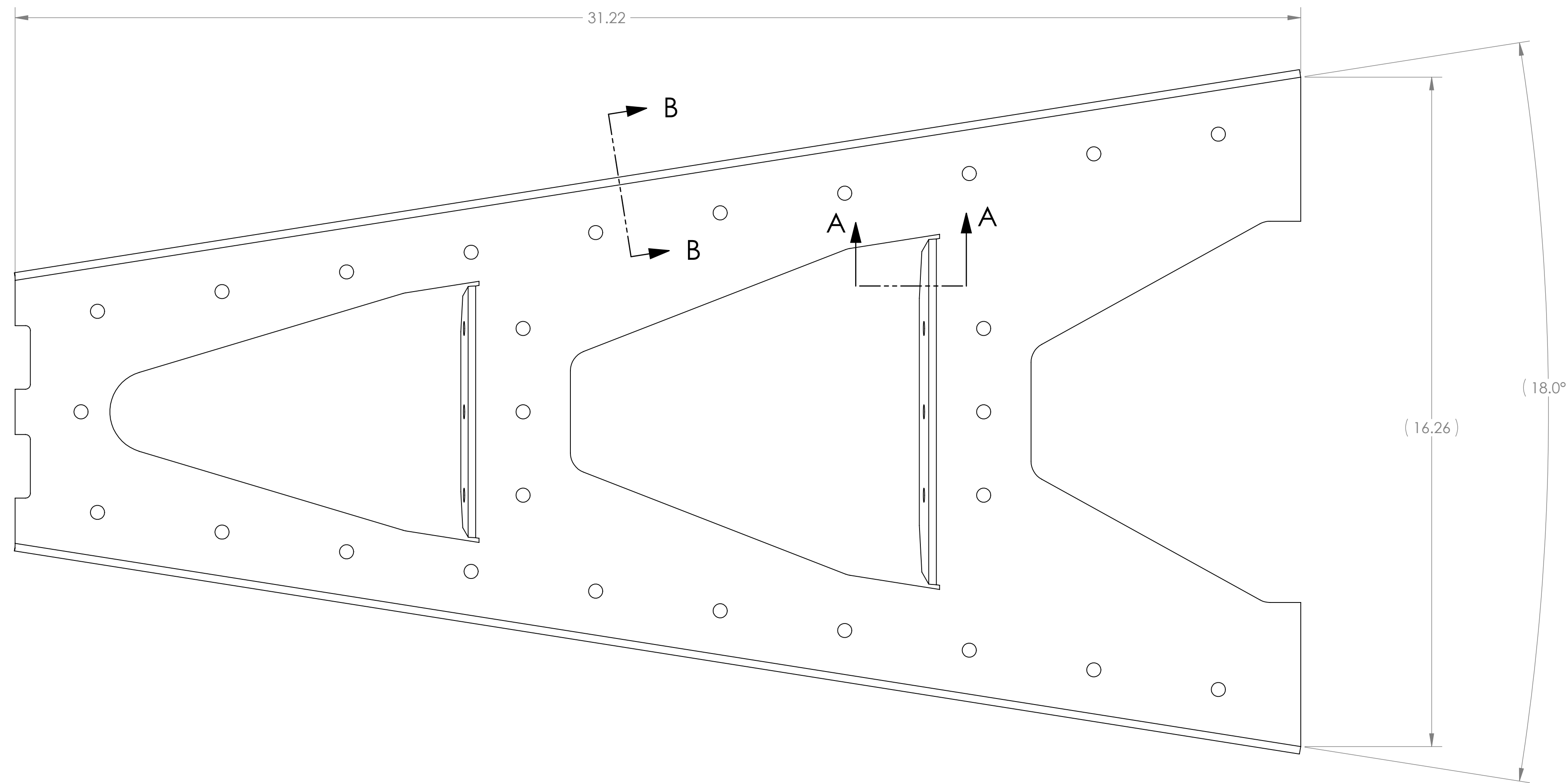
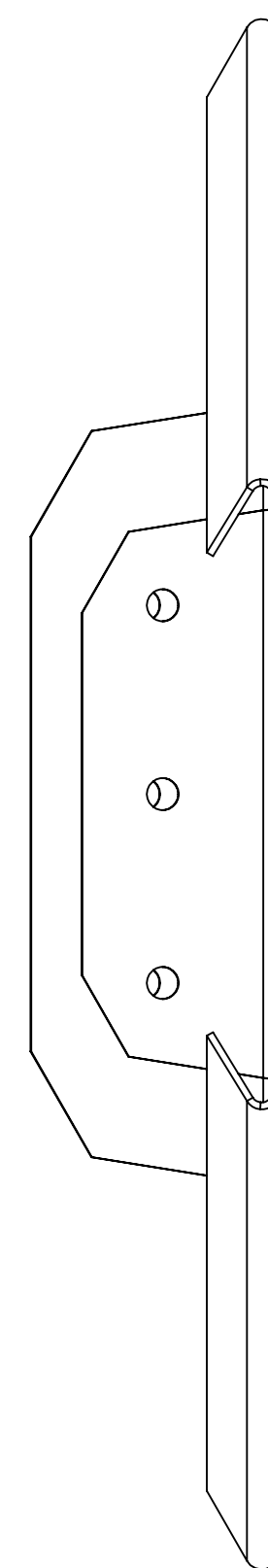

DIMENSIONS ARE IN INCHES		NOTES AND TOLERANCES: (UNLESS OTHERWISE SPECIFIED)		LIGO CALIFORNIA INSTITUTE OF TECHNOLOGY MASSACHUSETTS INSTITUTE OF TECHNOLOGY		PART NAME			
TOLERANCES: .XX ± .01 .XXX ± .005		1. INTERPRET DRAWING PER ASME Y14.5-1994. 2. REMOVE ALL SHARP EDGES, R.02 MIN. 3. DO NOT SCALE FROM DRAWING. 4. ALL MACHINING FLUIDS MUST BE FULLY SYNTHETIC, FULLY WATER SOLUBLE AND FREE OF SULFUR, SILICONE, AND CHLORINE.		SYSTEM ADVANCED LIGO		SUB-SYSTEM AOS		ALIGO AOS OPLEV TX PIER SIDE PANEL (TM)	
ANGULAR ± 1.0°		MATERIAL 304 SSSL SHEET, 14 GAUGE		FINISH (1)		NEXT ASSY D1000452		DESIGNER C. CONLEY	
								16 JUNE 2009	
								SIZE D	
								DWG. NO. D1001655	
								REV. v1	
								SCALE: 1:2	
								PROJECTION:	
								SHEET 1 OF 2	

D1001655.dwg CALIGO AOS Oplev TX Pier Side Panel (TM) (LLO). PART PDM REV: X-003. DRAWING PDM REV: X-005

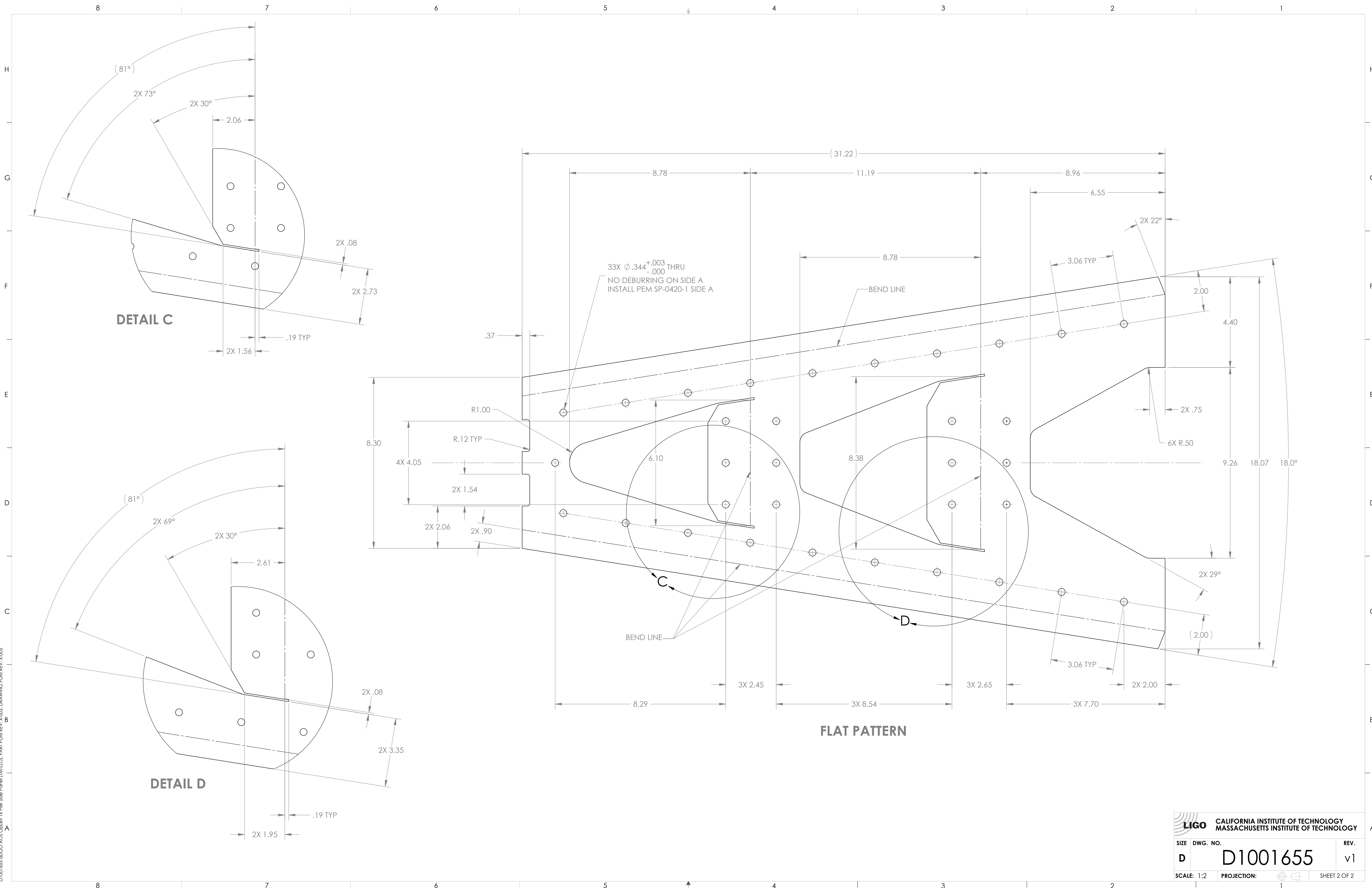

<b>LIGO</b> CALIFORNIA INSTITUTE OF TECHNOLOGY MASSACHUSETTS INSTITUTE OF TECHNOLOGY	
SIZE DWG. NO.	REV.
<b>D</b> <b>D1001655</b>	v1
SCALE: 1:2	PROJECTION:
SHEET 2 OF 2	

D:\001655\aligo\ACS-Celest-TX-Pipe-Side-Panels\DWG\1001655.DWG PART PDM REV: X-003 DRAWING PDM REV: X-005

NOTES CONTINUED:  
 Ⓢ RAPID CUTTING METHOD ACCEPTABLE FOR OUTER PROFILE AND Ø 3.80 HOLE.

REV.	DATE	DCN #	DRAWING TREE #
v1	25 MAY 2010	E1000182-v1	-
-	-	-	-
-	-	-	-

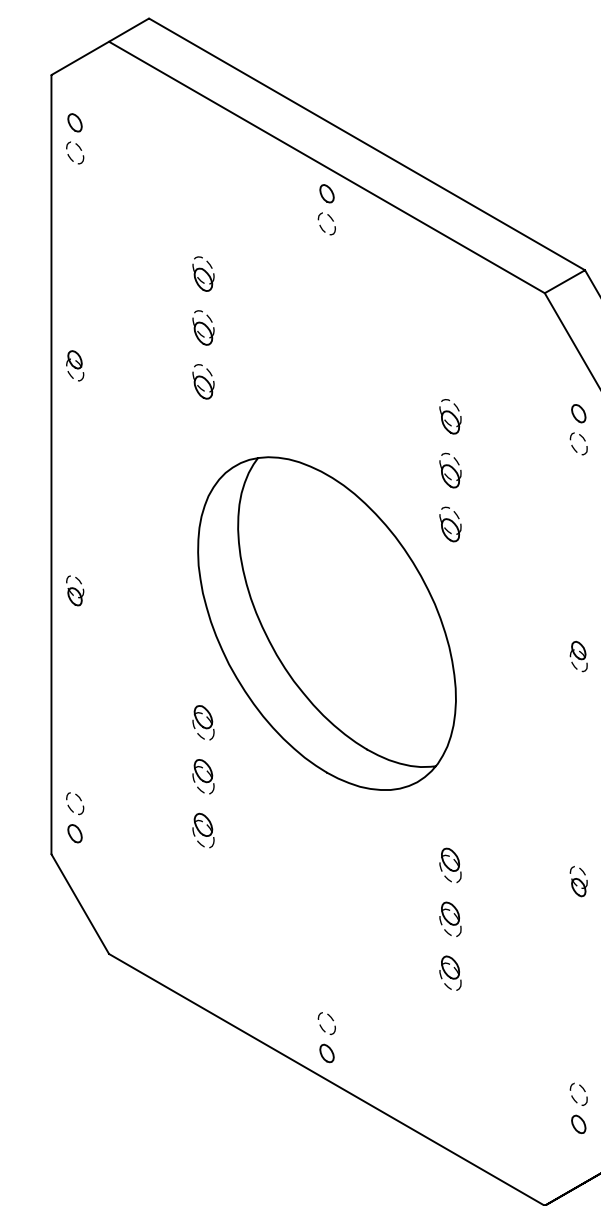
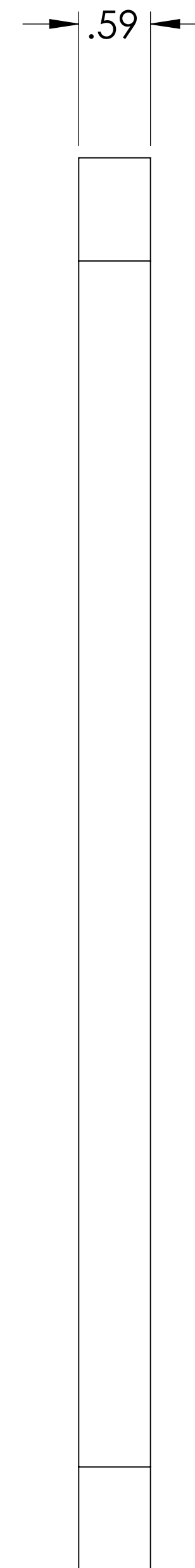
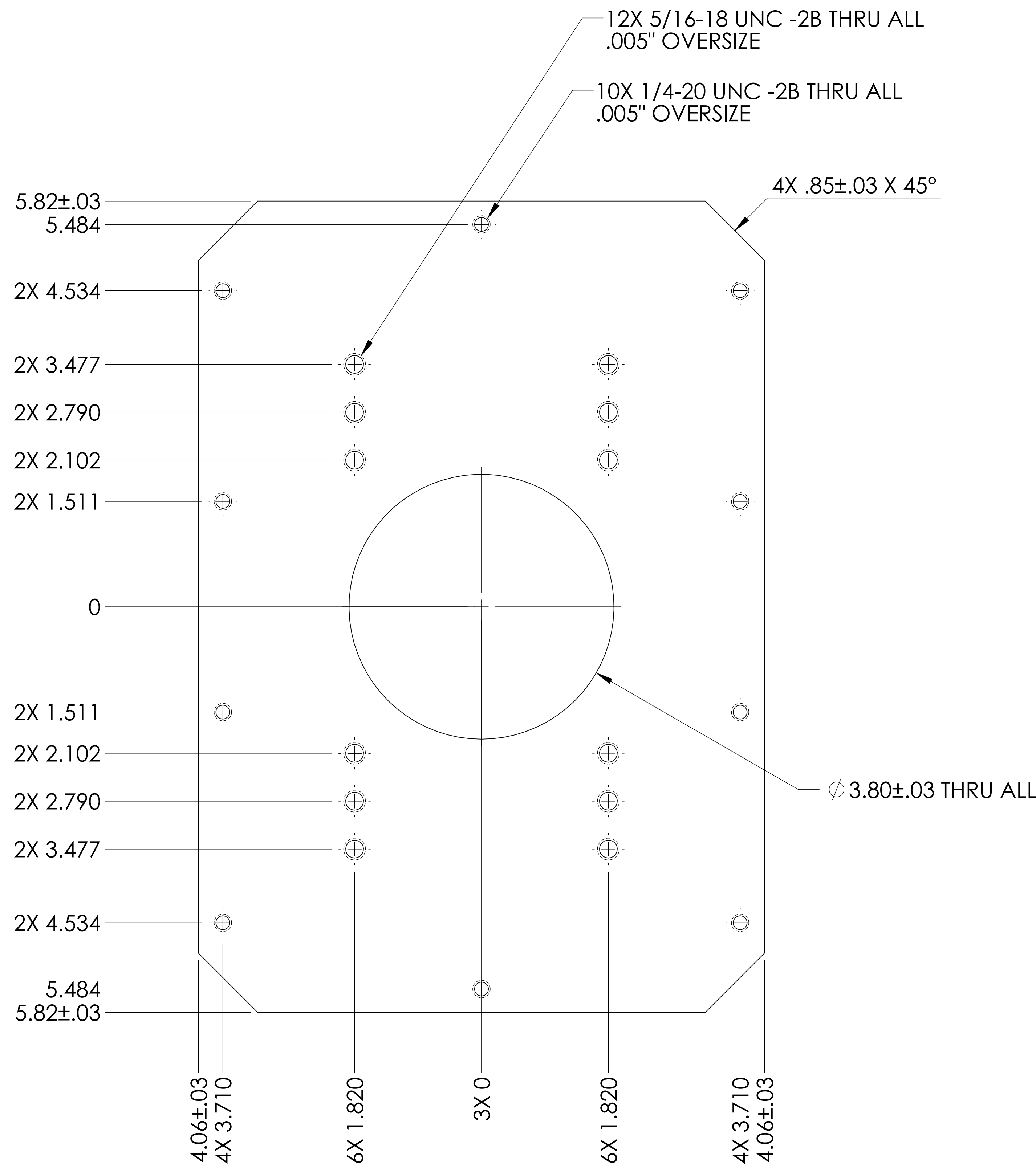

ISO VIEW

NOTES AND TOLERANCES: (UNLESS OTHERWISE SPECIFIED)		LIGO CALIFORNIA INSTITUTE OF TECHNOLOGY MASSACHUSETTS INSTITUTE OF TECHNOLOGY		PART NAME	
DIMENSIONS ARE IN INCHES TOLERANCES: .XX ± .01 .XXX ± .005 ANGULAR ± 1.0°		1. INTERPRET DRAWING PER ASME Y14.5-1994. 2. REMOVE ALL SHARP EDGES, R.02 MIN. 3. DO NOT SCALE FROM DRAWING. 4. ALL MACHINING FLUIDS MUST BE FULLY SYNTHETIC, FULLY WATER SOLUBLE AND FREE OF SULFUR, SILICONE, AND CHLORINE.		<b>ALIGO AOS</b> <b>OPLEV TX PIER TABLE (TM)</b>	
MATERIAL 304 SSSL		FINISH 63 μinch		DESIGNER C. CONLEY 07 MAY 2009	
NEXT ASSY D0900423		SUB-SYSTEM AOS		SIZE DWG. NO. D D1000425	
		CHECKER N. KILPATRICK 25 MAY 2010		REV. v1	
		APPROVAL		SCALE: 1:1 PROJECTION:	
				SHEET 1 OF 1	

D1000425.dwg CALIGO AOS Oplev TX Pier Table (TM) PART PDM REV: X024 DRAWING PDM REV: X014

- NOTES CONTINUED:**
- ⑤ SCRIBE, ENGRAVE, OR MECHANICALLY STAMP (NO INKS OR DYES) DRAWING PART NUMBER, REVISION (AND VARIANT OR TYPE IF APPLICABLE) ON NOTED SURFACE OF PART FOLLOWED ON THE NEXT LINE WITH A THREE DIGIT SERIAL NUMBER. SERIAL NUMBERS START AT 001 FOR THE FIRST ARTICLE AND PROCEED CONSECUTIVELY. USE MINIMUM 0.12" HIGH CHARACTERS, UNLESS THE SIZE OF THE PART DICTATES SMALLER CHARACTERS. A VIBRATORY TOOL MAY BE USED. EXAMPLE: DXXXXXX-VY, TYPE-XX, S/N XXX
  - ⑥ FASTEN ITEMS 1 TO D1000836 FOOTING BEFORE APPLYING NOTED WELDS, TO ENSURE ALIGNMENT. FOR EACH ITEM 1, USE THREE 1/2-20 UNF SCREWS TO TAPPED HOLES IN FOOTING. FOOTING MUST BE REMOVABLE & RE-ATTACHABLE POST-WELD, WITH NO BINDING OF SCREWS. TO BE DELIVERED WITH FOOTING ATTACHED.
  - ⑦ WARPAGE OF ITEM 1 & FOOTING TO BE MINIMIZED USING PREFERRED METHODS, IE. HEAT SINKING.

REV.	DATE	DCN #	DRAWING TREE #
v1	17 AUGUST 2010	E1000182-v1	-
-	-	-	-
-	-	-	-

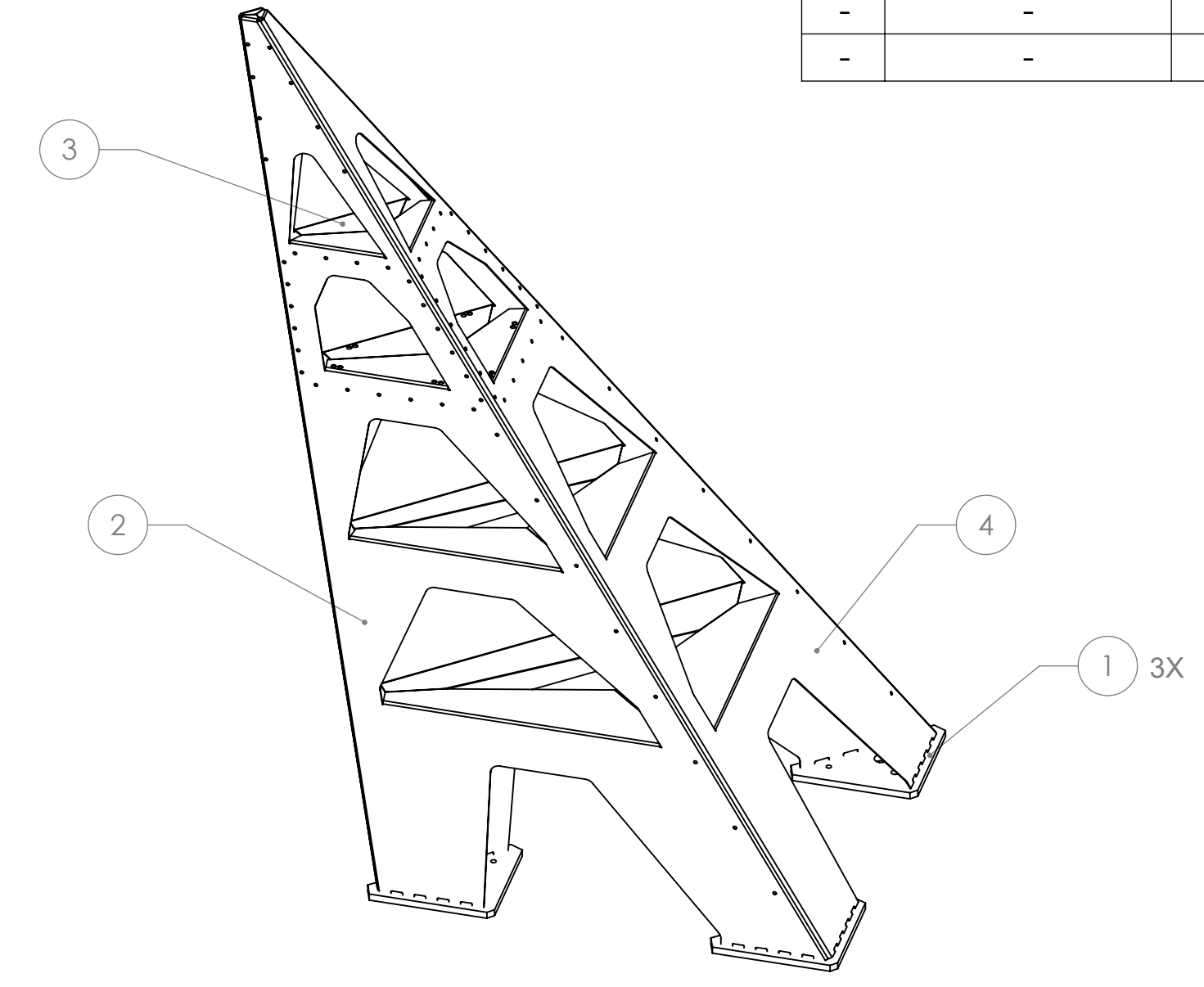
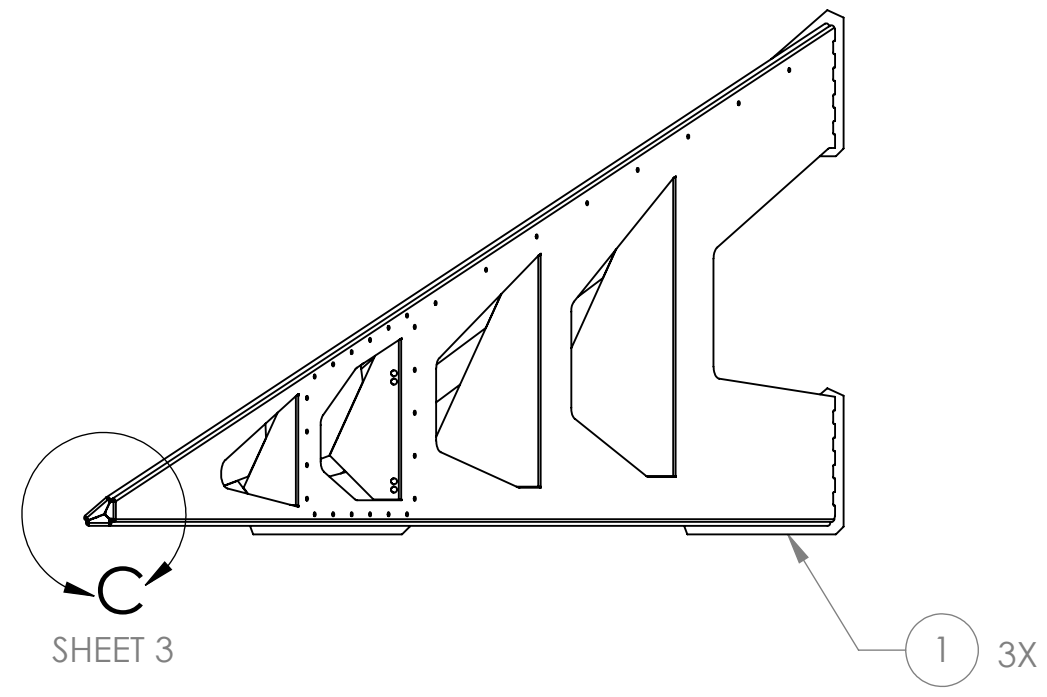

ISO VIEW

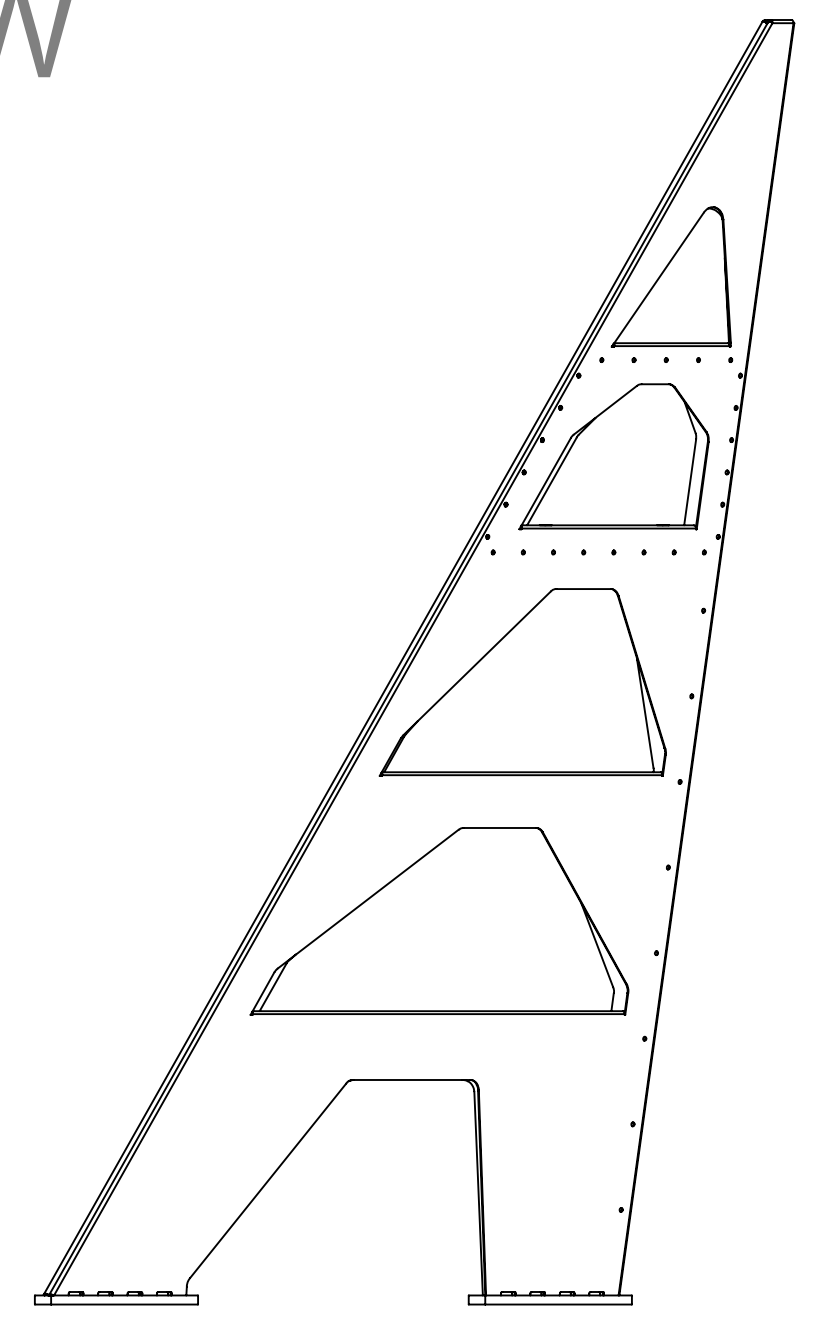
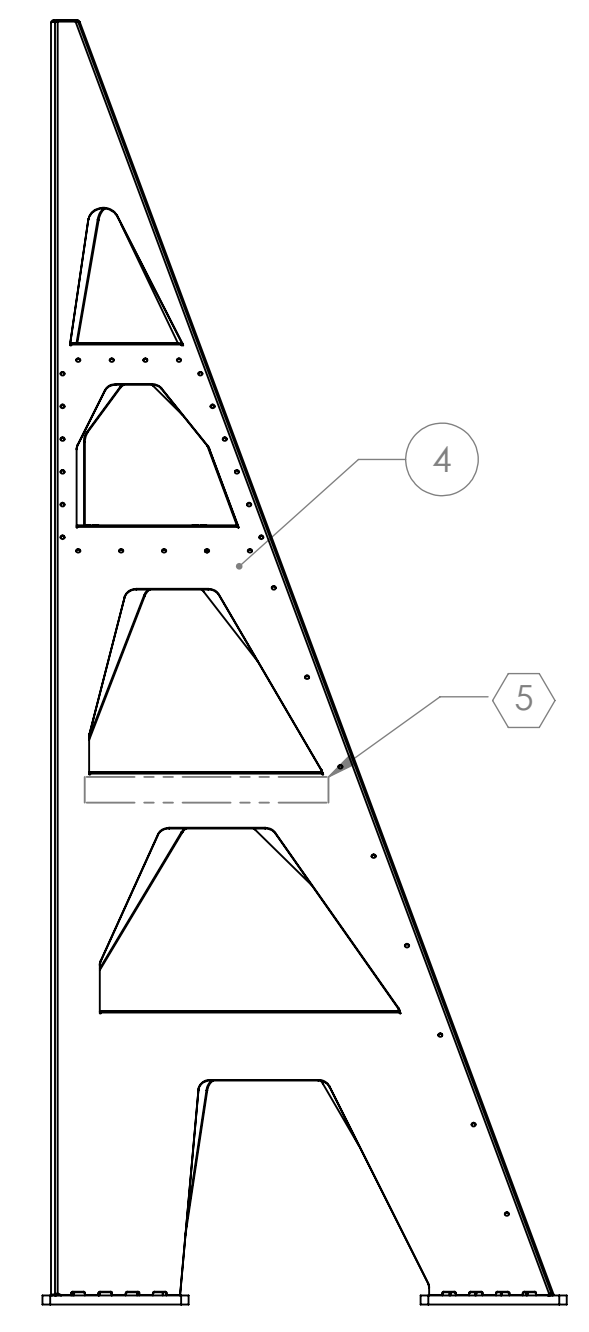
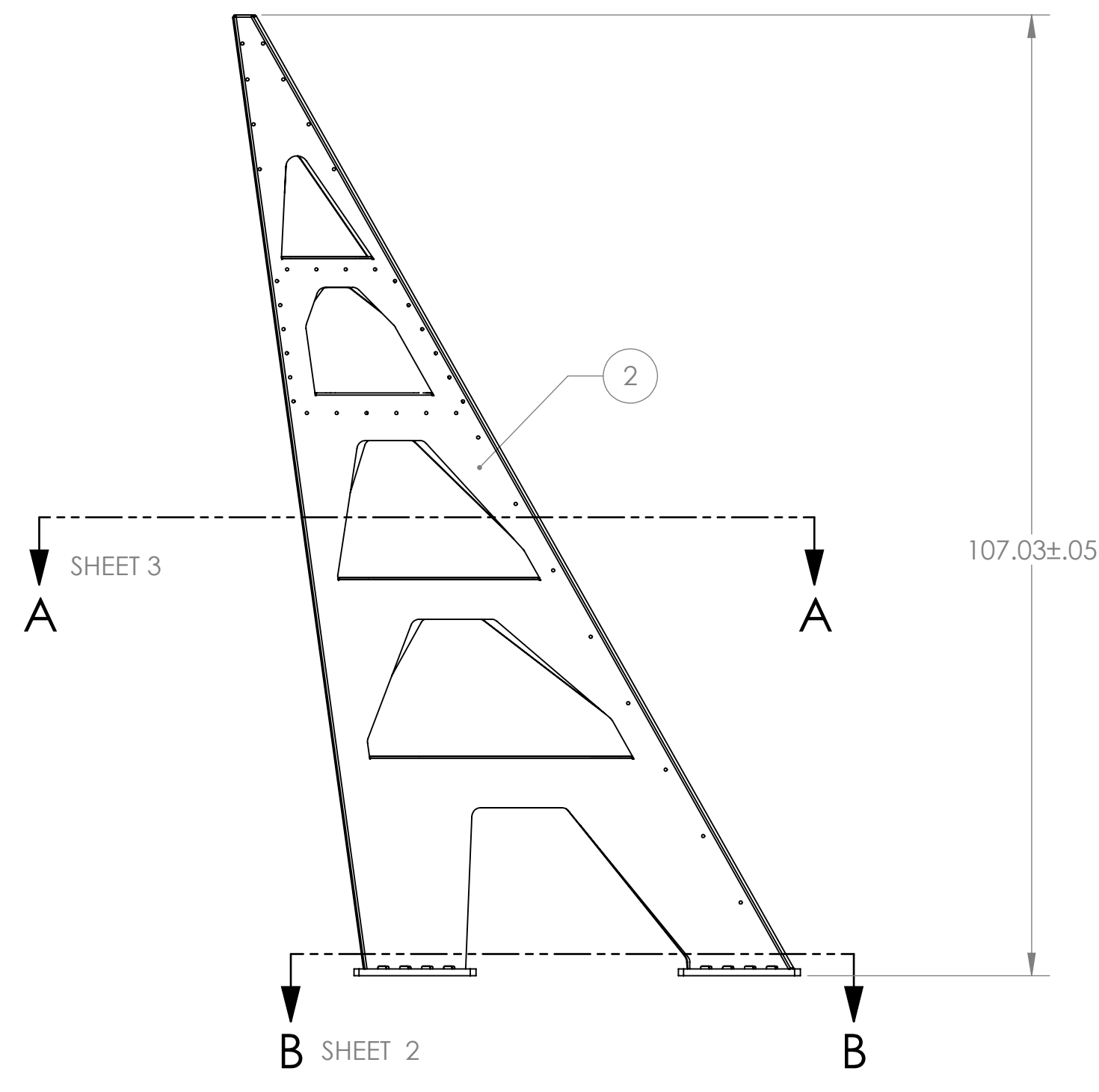
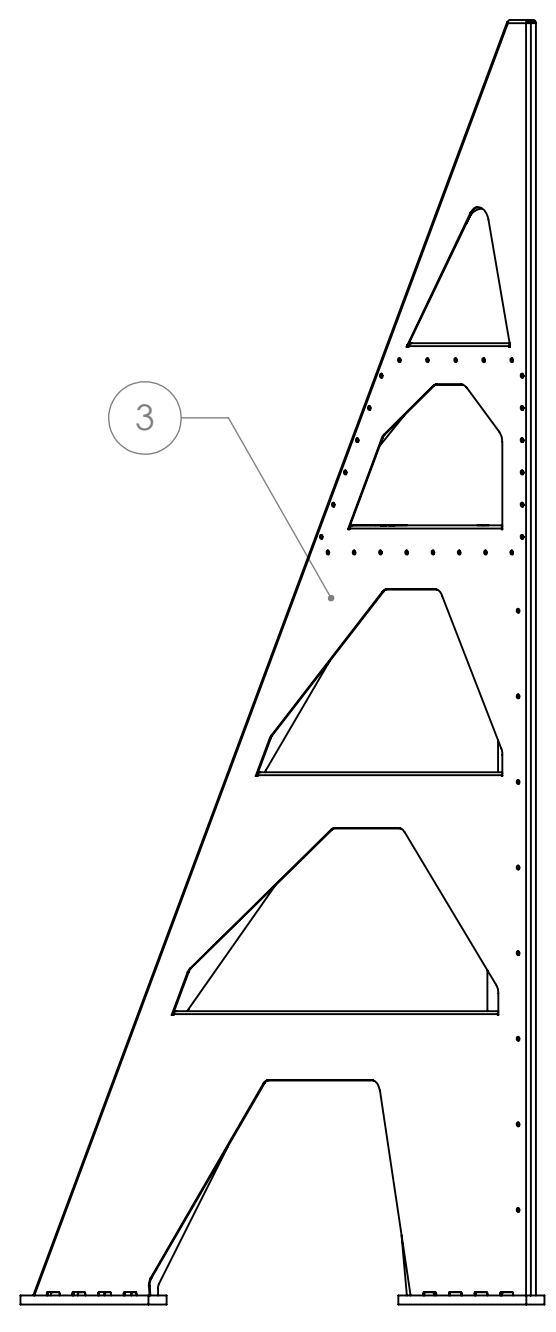

ITEM NO.	PART NUMBER	DESCRIPTION	MATERIAL	REQ	SPARE	TOTAL
4	D1000596-1	ALIGO AOS OPLEV & PHOTCAL RX PIER SIDE PANEL3 (LLO)	304 SSSL	1		1
3	D1000594-1	ALIGO AOS OPLEV & PHOTCAL RX PIER SIDE PANEL1 (LLO)	304 SSSL	1		1
2	D1000595-1	ALIGO AOS OPLEV & PHOTCAL RX PIER SIDE PANEL2 (LLO)	304 SSSL	1		1
1	D1000835	ALIGO AOS PIER BASE 4	304 SSSL	3		3

NOTES AND TOLERANCES: (UNLESS OTHERWISE SPECIFIED)	
1. INTERPRET DRAWING PER ASME Y14.5-1994. 2. REMOVE ALL SHARP EDGES, R.02 MIN. 3. DO NOT SCALE FROM DRAWING. 4. ALL MACHINING FLUIDS MUST BE FULLY SYNTHETIC, FULLY WATER SOLUBLE AND FREE OF SULFUR, SILICONE, AND CHLORINE.	
DIMENSIONS ARE IN	
TOLERANCES:	
.XX ± N/A	
.XXX ± N/A	
ANGULAR ± N/A °	
MATERIAL	N/A
FINISH	N/A μinch

CALIFORNIA INSTITUTE OF TECHNOLOGY MASSACHUSETTS INSTITUTE OF TECHNOLOGY	
SYSTEM	ADVANCED LIGO
SUB-SYSTEM	AOS
NEXT ASSY	D1001325

PART NAME		ALIGO AOS OPLEV & PHOTCAL RX PIER WELDMNT LH			
DESIGNER	C. CONLEY	16 AUG 2010	SIZE	DWG. NO.	REV.
DRAFTER	N. KILPATRICK	17 AUG 2010	D	D1001292	v1
CHECKER			SCALE: 1:16	PROJECTION:	SHEET 1 OF 3
APPROVAL					

D1001292.dwg: AOS Oplev & Photcal RX Pier Weldment LH (LLO) - PART EDM REV: X-005, DRAWING PDM REV: X-012

8 7 6 5 4 3 2 1

H  
G  
F  
E  
D  
C  
B  
A

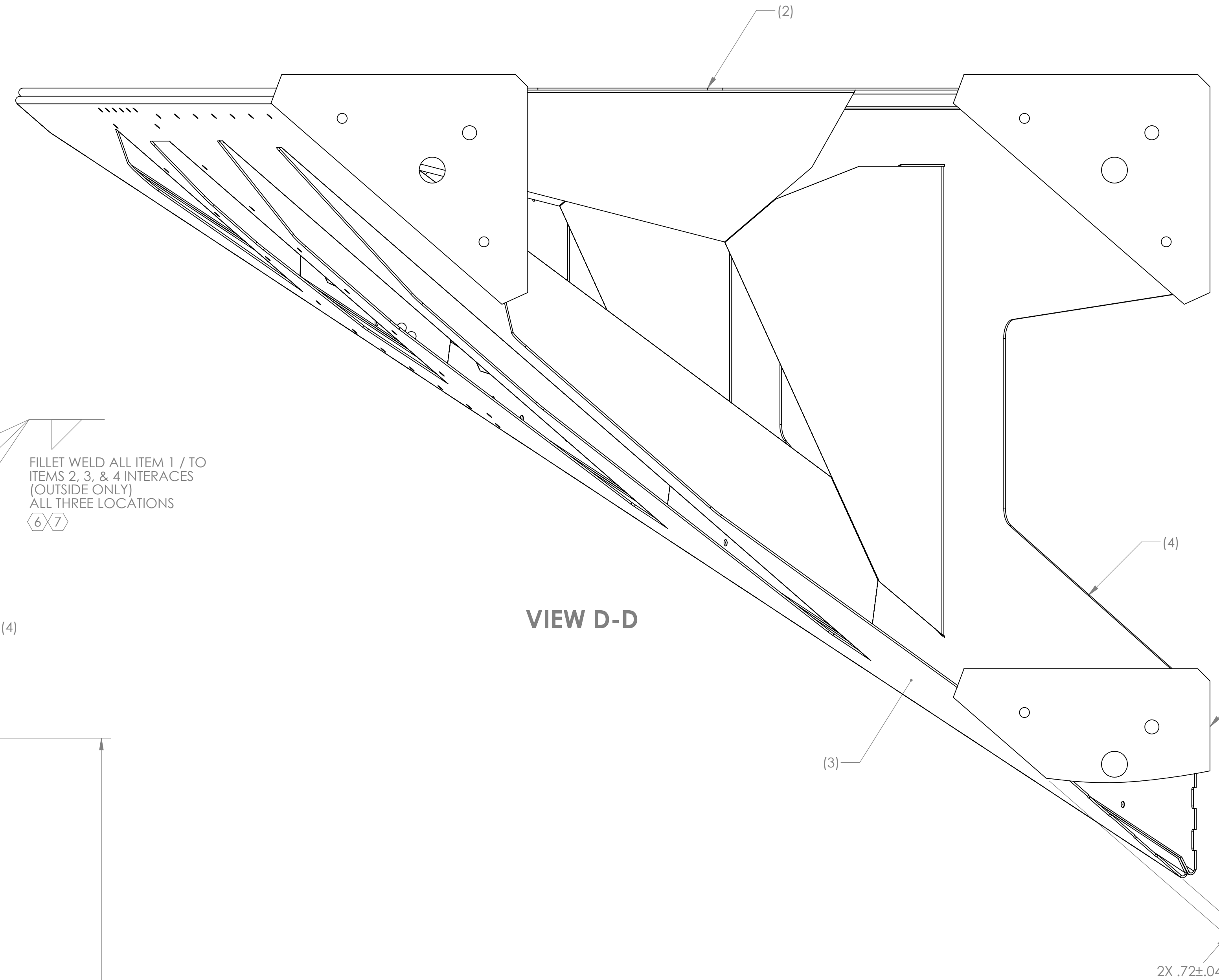

VIEW D-D

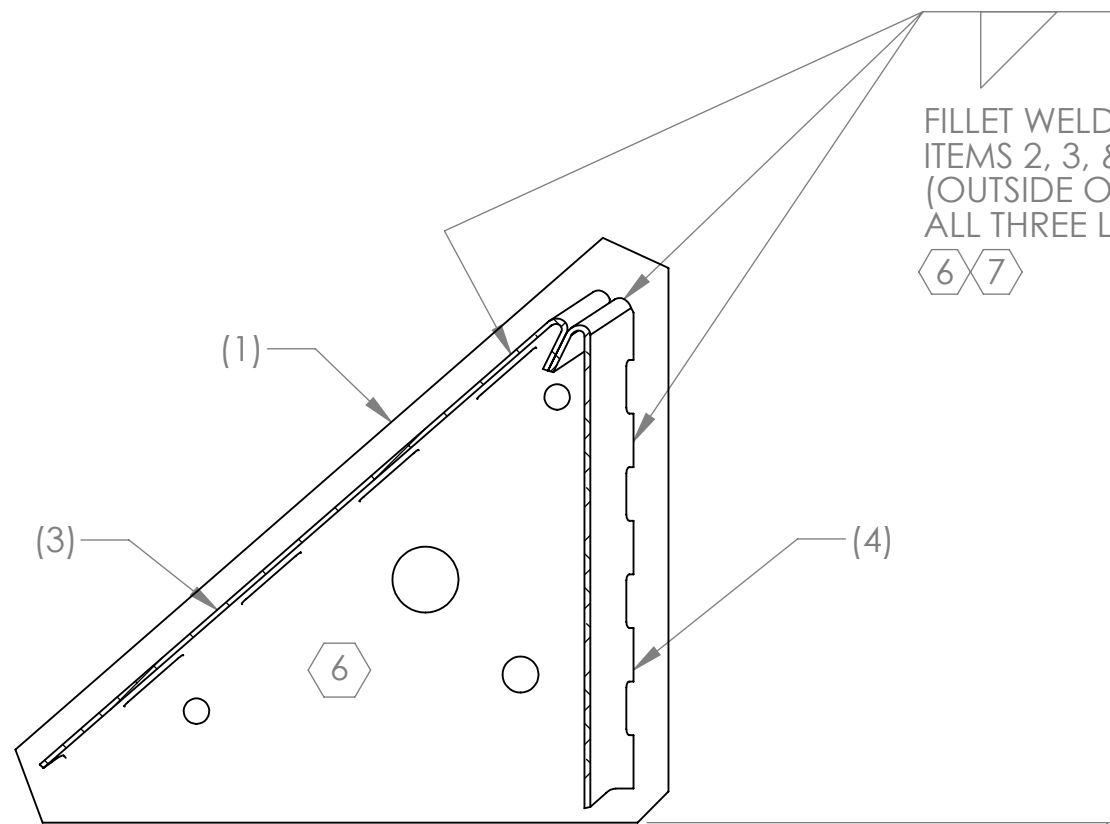

FILLET WELD ALL ITEM 1 / TO  
ITEMS 2, 3, & 4 INTERACES  
(OUTSIDE ONLY)  
ALL THREE LOCATIONS  
6/7

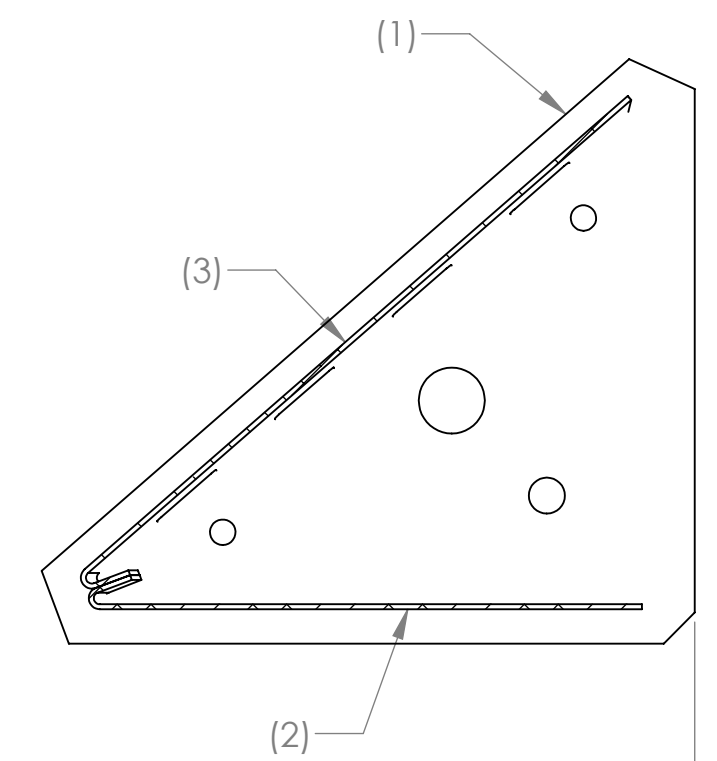

SECTION B-B

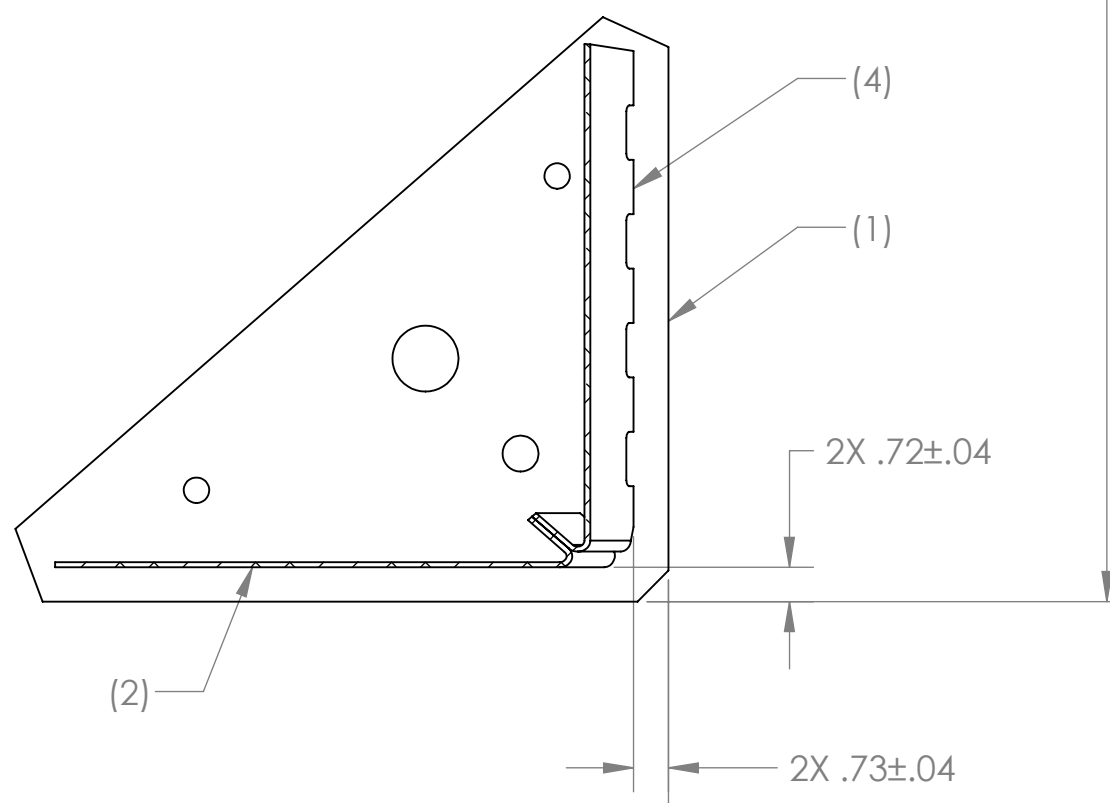

(31.50)

(36.16)

<b>LIGO</b> CALIFORNIA INSTITUTE OF TECHNOLOGY MASSACHUSETTS INSTITUTE OF TECHNOLOGY		REV.
SIZE DWG. NO.	D1001292	v1
SCALE: 1:4	PROJECTION:	SHEET 2 OF 3

D:\001292.dwg ACS Octave & Photo RX Per Weldment LH (LO) PART EDM REV: X-05 DRAWING PDM REV: X-012

8 7 6 5 4 3 2 1

D:\001292.dwg ACS Octave & Photo RX Per Weldment LH (LO) PART EDW\REV: X-005 DRAWING PDM REV: X-012

8 7 6 5 4 3 2 1

H G F E D C B A

H G F E D C B A

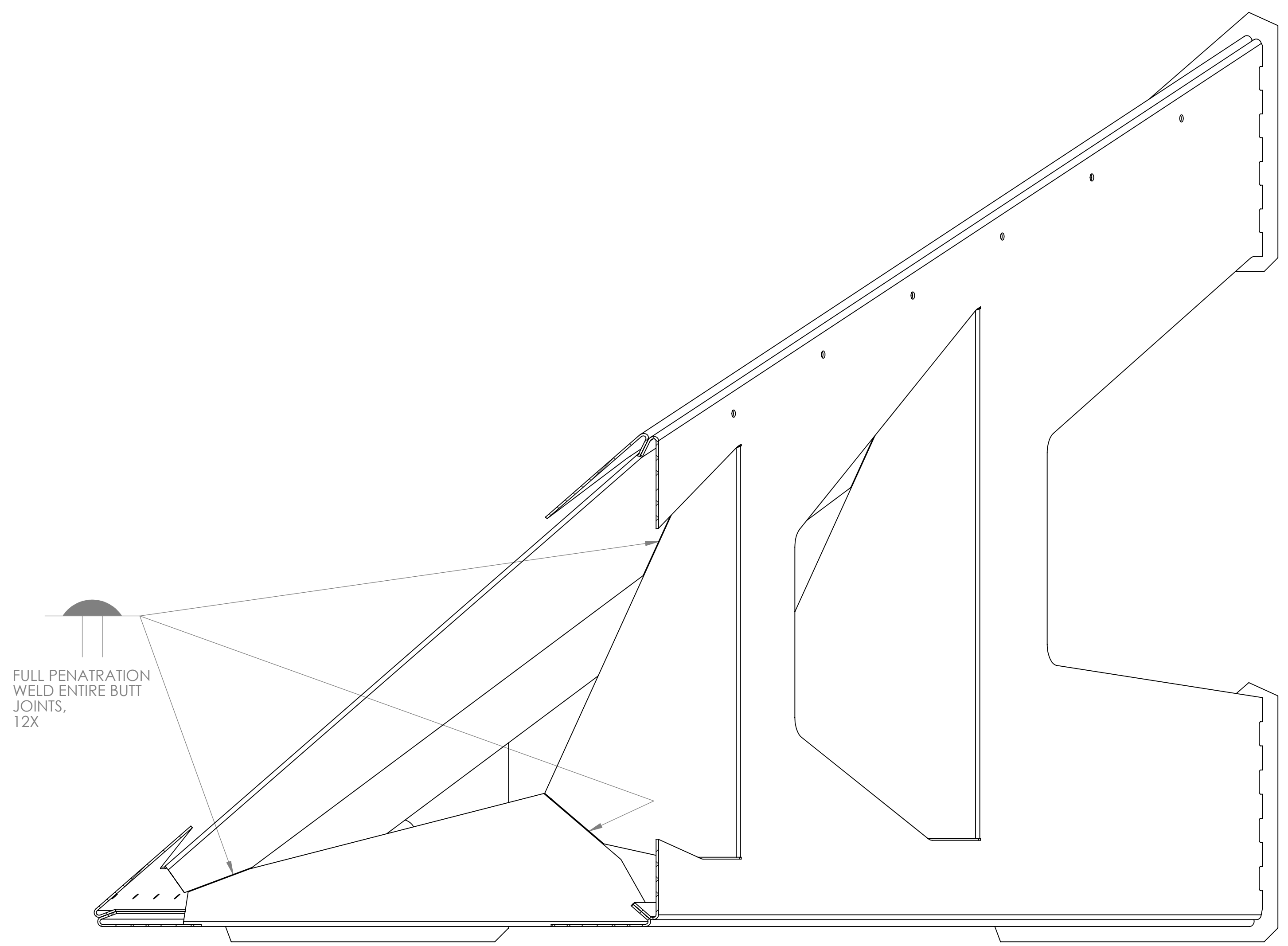

SECTION A-A  
SCALE 1 : 4

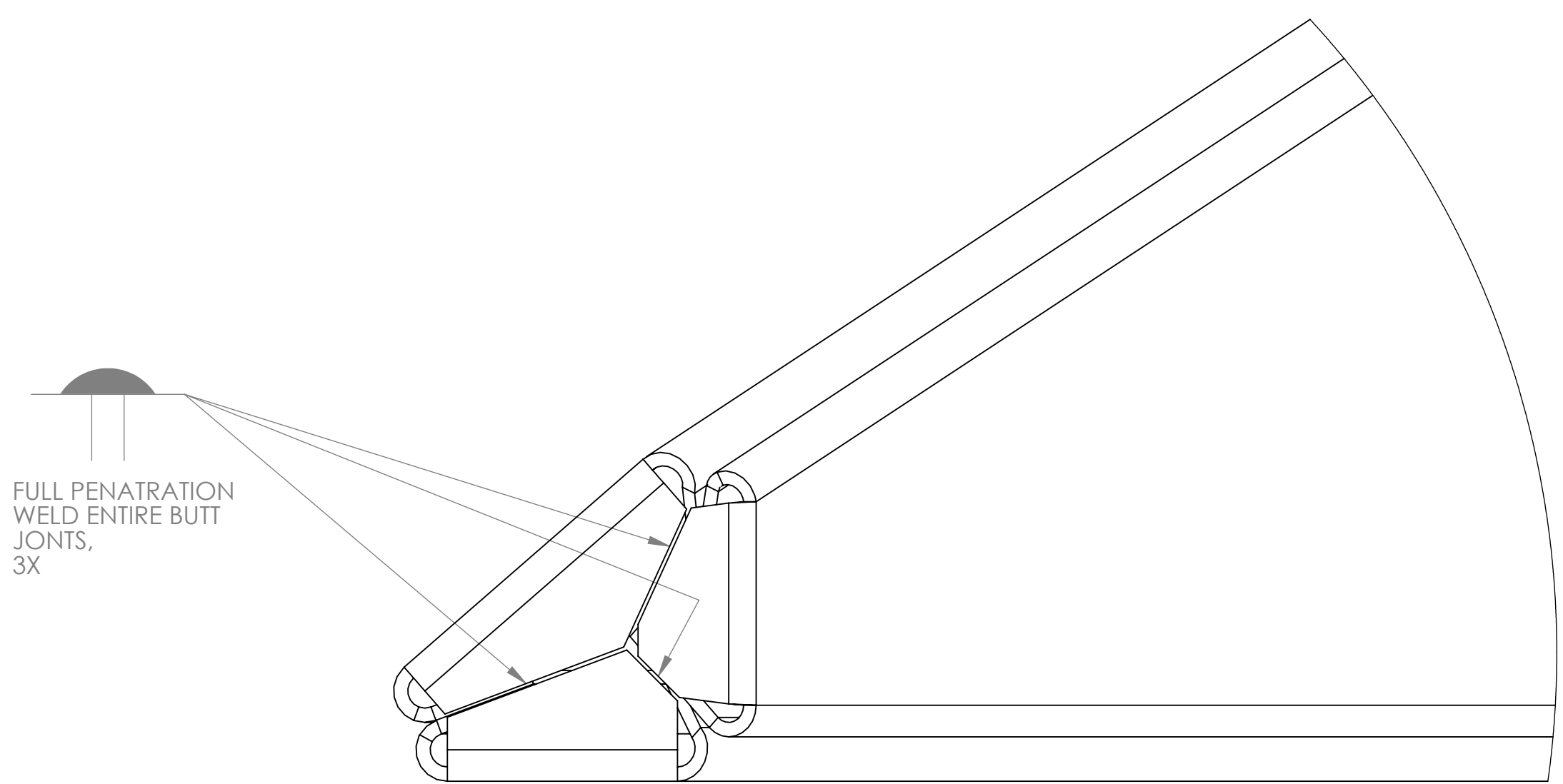

DETAIL C  
SCALE 1 : 1

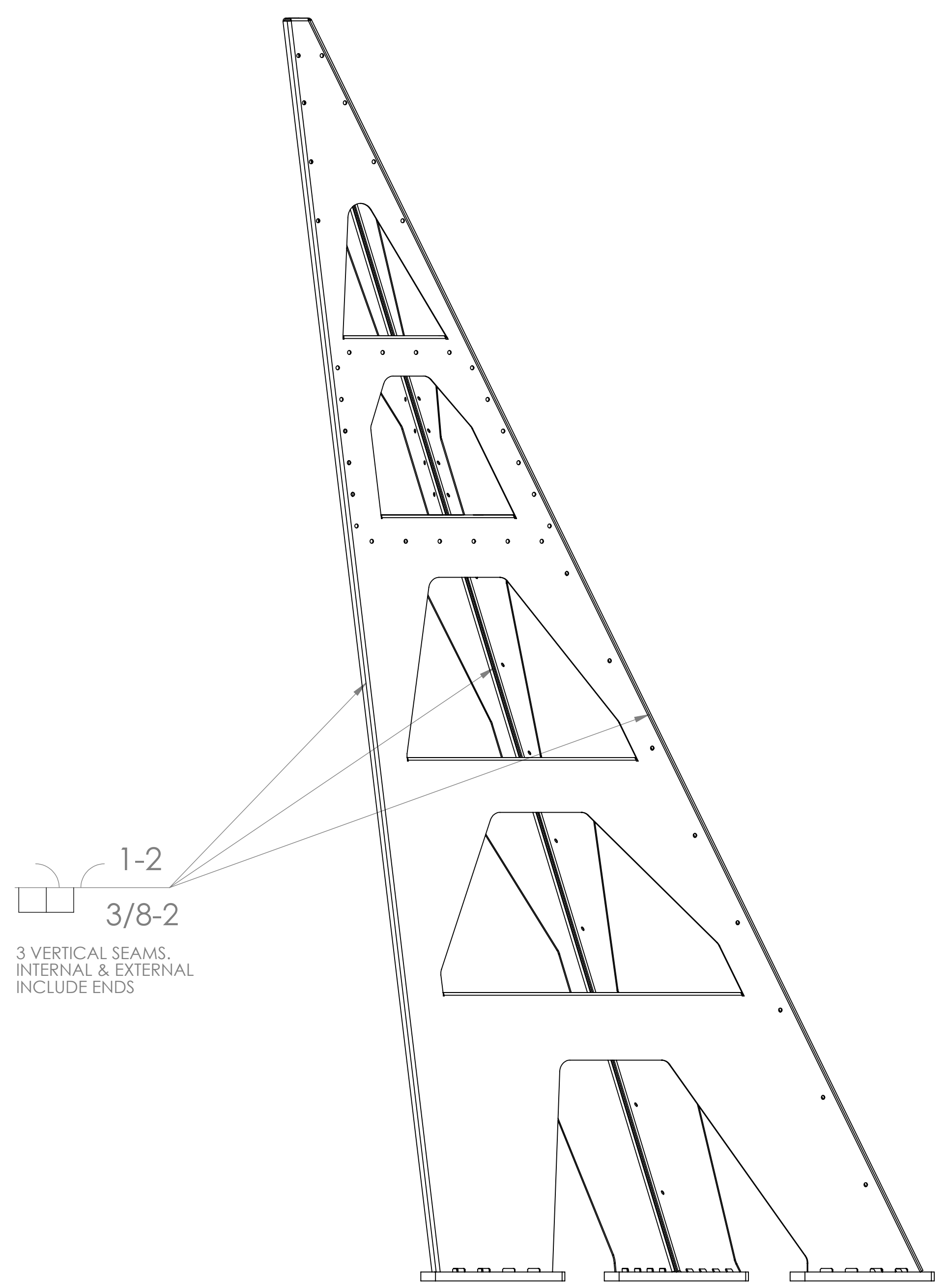

1-2  
3/8-2  
3 VERTICAL SEAMS.  
INTERNAL & EXTERNAL  
INCLUDE ENDS

		CALIFORNIA INSTITUTE OF TECHNOLOGY MASSACHUSETTS INSTITUTE OF TECHNOLOGY	
SIZE	DWG. NO.	REV.	
D	D1001292	v1	
SCALE: 1:8	PROJECTION:	SHEET 3 OF 3	



NOTES CONTINUED:  
 5. -1 (1.75 THICKNESS) FOR LHO, -2 (.75 THICKNESS) FOR LLO.  
 6. RAPID CUTTING METHOD ACCEPTABLE FOR OUTER PROFILE AND  $\phi$  1.38 HOLE.

REV.	DATE	DCN #	DRAWING TREE #
v1	04 JUNE 2010	D1000182-v1	-
-	-	-	-
-	-	-	-

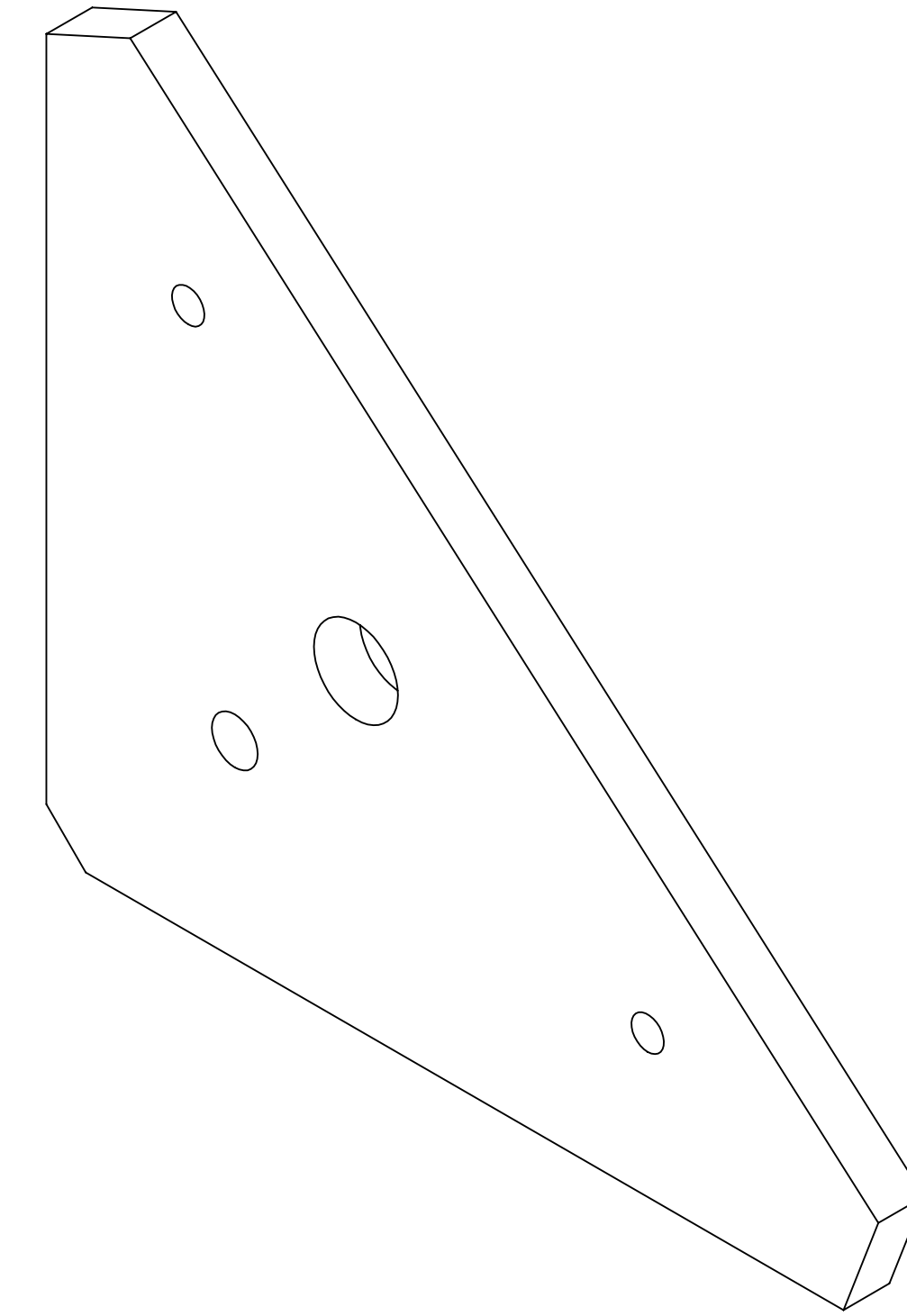
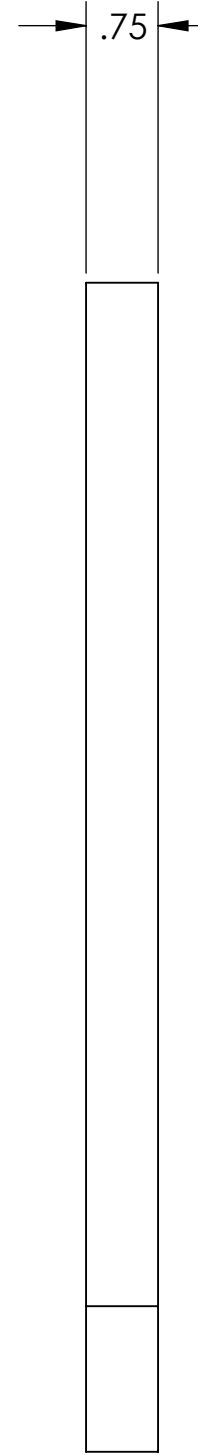
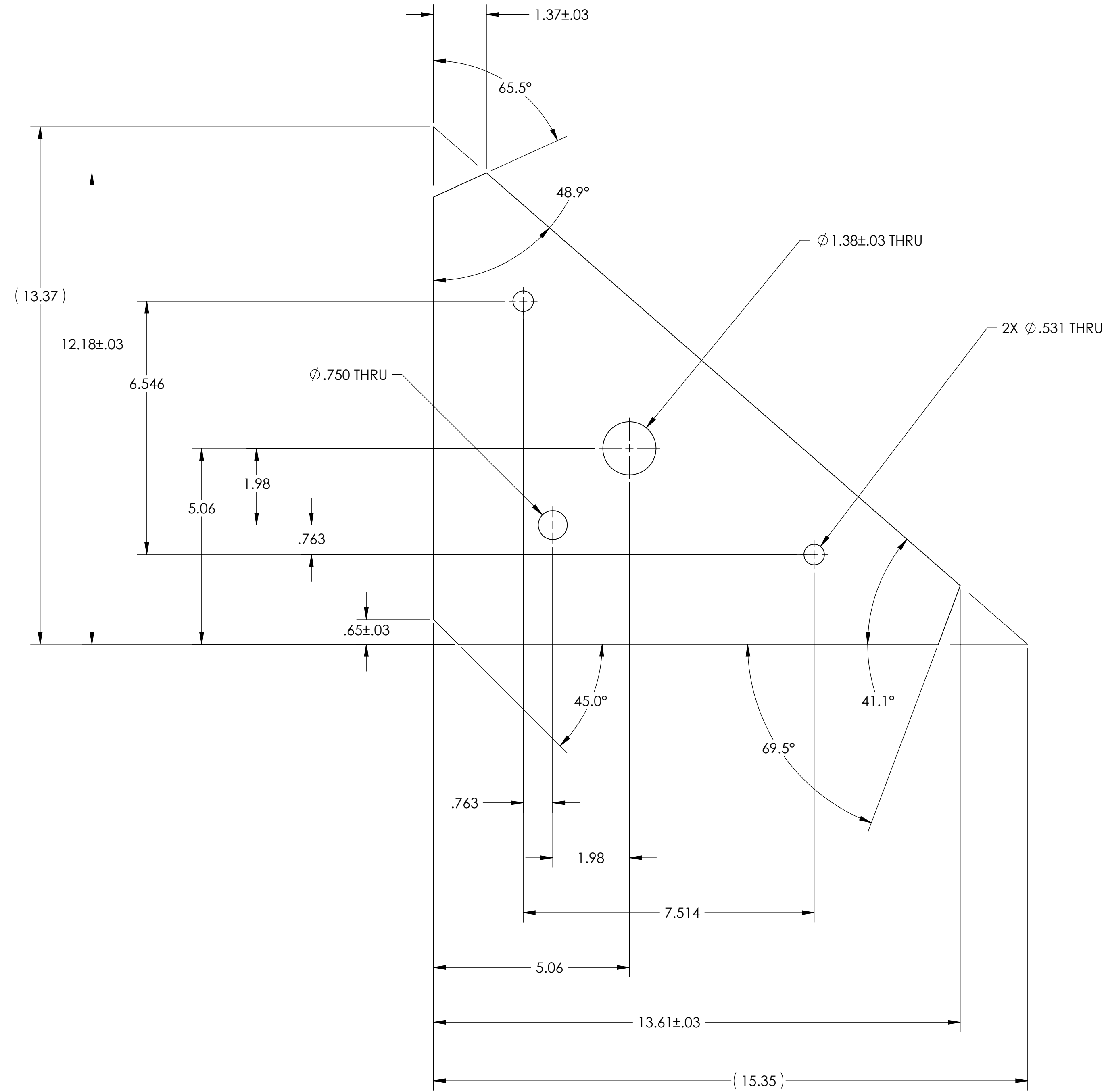

ISO VIEW

DIMENSIONS ARE IN INCHES		NOTES AND TOLERANCES: (UNLESS OTHERWISE SPECIFIED)		CALIFORNIA INSTITUTE OF TECHNOLOGY MASSACHUSETTS INSTITUTE OF TECHNOLOGY		PART NAME	
TOLERANCES: .XX ± .01 .XXX ± .005		1. INTERPRET DRAWING PER ASME Y14.5-1994. 2. REMOVE ALL SHARP EDGES, R.02 MIN. 3. DO NOT SCALE FROM DRAWING. 4. ALL MACHINING FLUIDS MUST BE FULLY SYNTHETIC, FULLY WATER SOLUBLE AND FREE OF SULFUR, SILICONE, AND CHLORINE.		SYSTEM <b>ADVANCED LIGO</b>		SUB-SYSTEM <b>AOS</b>	
ANGULAR ± 1.0°		MATERIAL		NEXT ASSY		DESIGNER C. CONLEY 06 APR 2010	
		304 SSSL		D1000522, D1000597, D1001292, D1001297		SIZE DWG. NO. <b>D D1000835</b>	
		FINISH				DRAFTER N. KILPATRICK 04 JUNE 2010	
		63 μinch				CHECKER APPROVAL	
						SCALE: 1:2 PROJECTION:	
						REV. v1	
						SHEET 1 OF 1	

D1000835.dwg AOS Rev B Rev 4 PART PDM REV X:032 DRAWING PDM REV X:011

NOTES CONTINUED:  
 5. SCRIBE, ENGRAVE, OR MECHANICALLY STAMP (NO INKS OR DYES) DRAWING PART NUMBER, REVISION (AND VARIANT OR TYPE IF APPLICABLE) ON NOTED SURFACE OF PART FOLLOWED ON THE NEXT LINE WITH A THREE DIGIT SERIAL NUMBER. SERIAL NUMBERS START AT 001 FOR THE FIRST ARTICLE AND PROCEED CONSECUTIVELY. USE MINIMUM 0.12" HIGH CHARACTERS, UNLESS THE SIZE OF THE PART DICTATES SMALLER CHARACTERS. A VIBRATORY TOOL MAY BE USED. EXAMPLE: DXXXXXX-VY, TYPE-XX, S/N XXX

6. DO NOT DEBURR HOLES.  
 7. FOR BOTH -1 & -2, SIDE A IS SIDE TOWARD FOLDS.  
 8. STOCK FINISH/AS RECEIVED.

REV.	DATE	DCN #	DRAWING TREE #
v1	17 AUGUST 2010	E1000182-v1	-
-	-	-	-
-	-	-	-

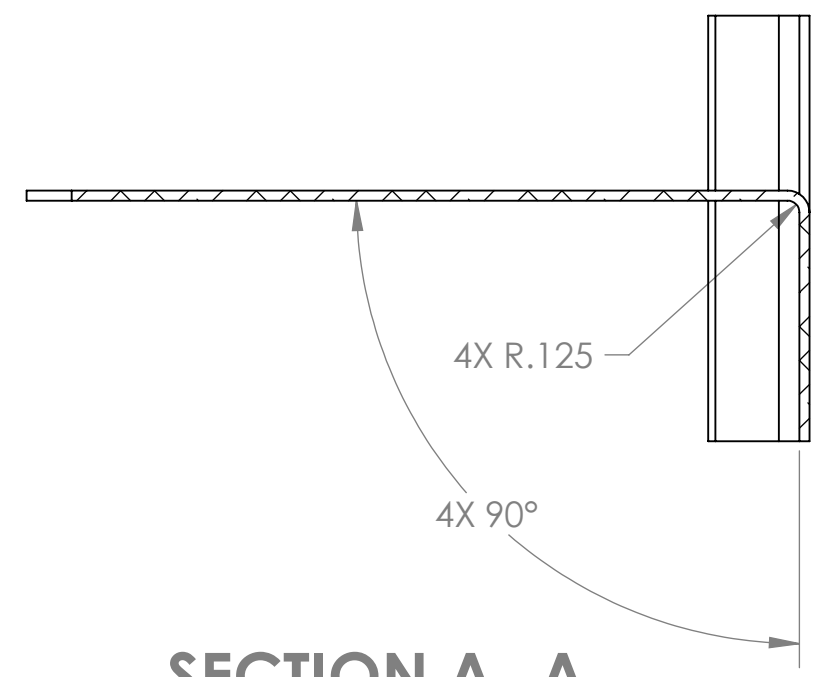

SECTION A-A  
SCALE 1 : 2

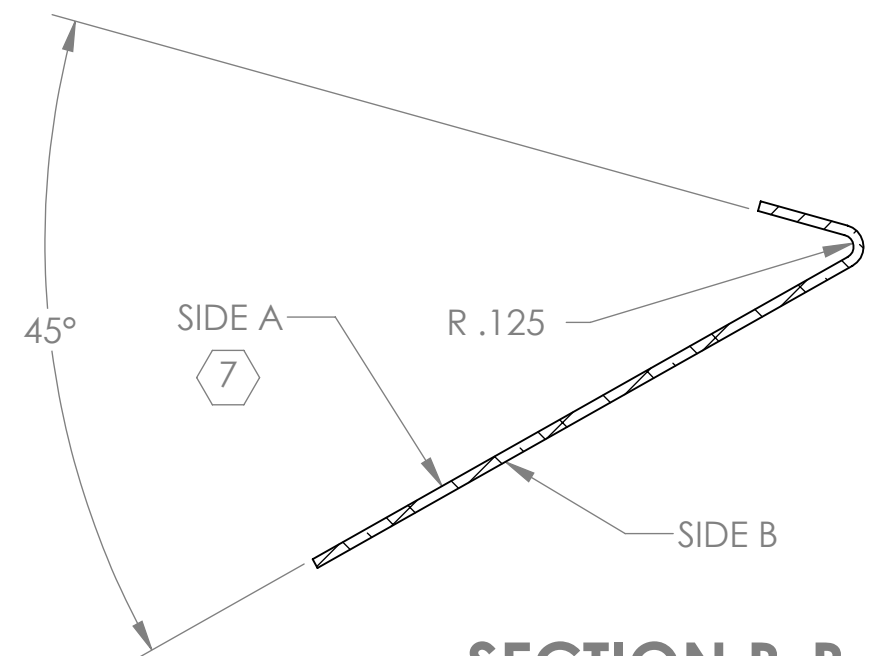

SECTION B-B  
SCALE 1 : 2

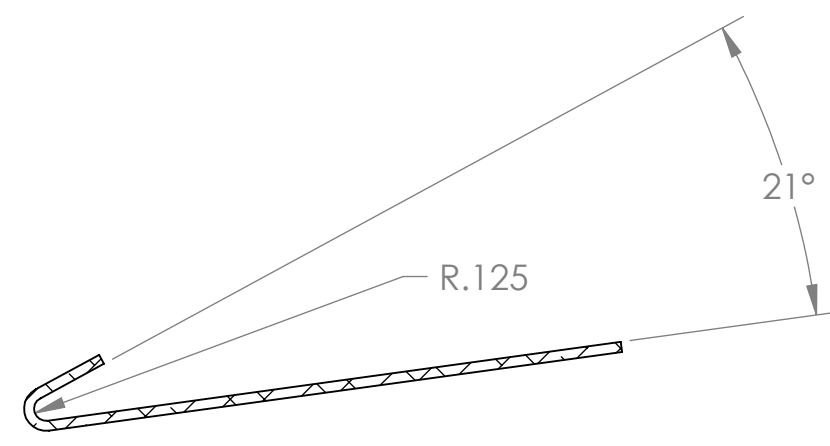

SECTION C-C  
SCALE 1 : 2

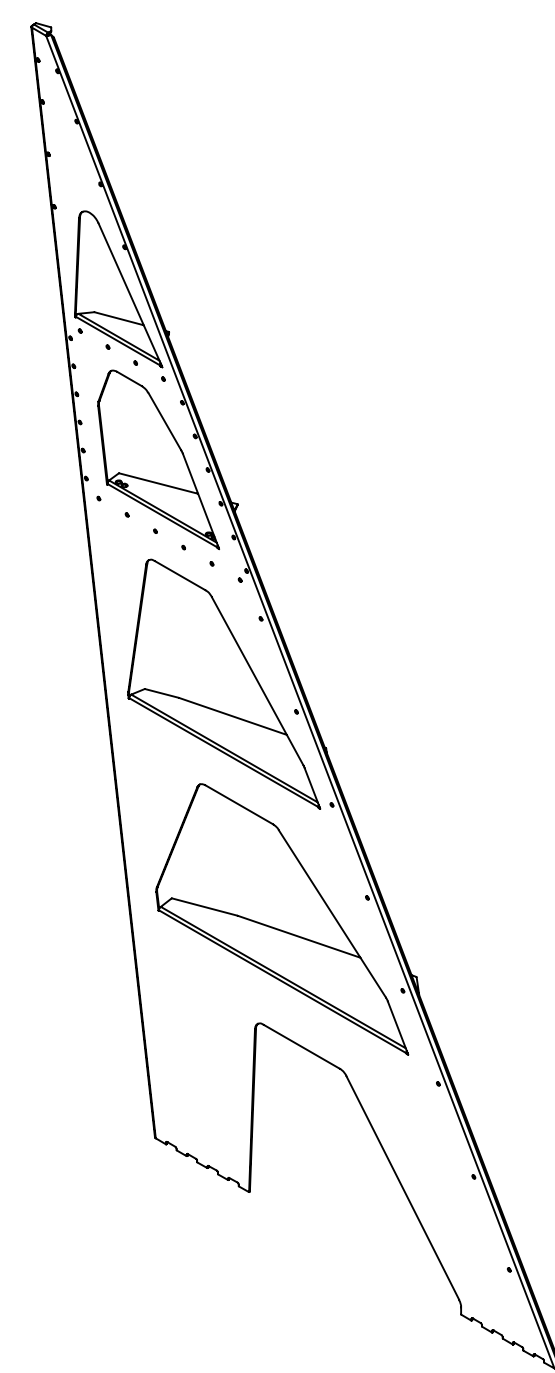
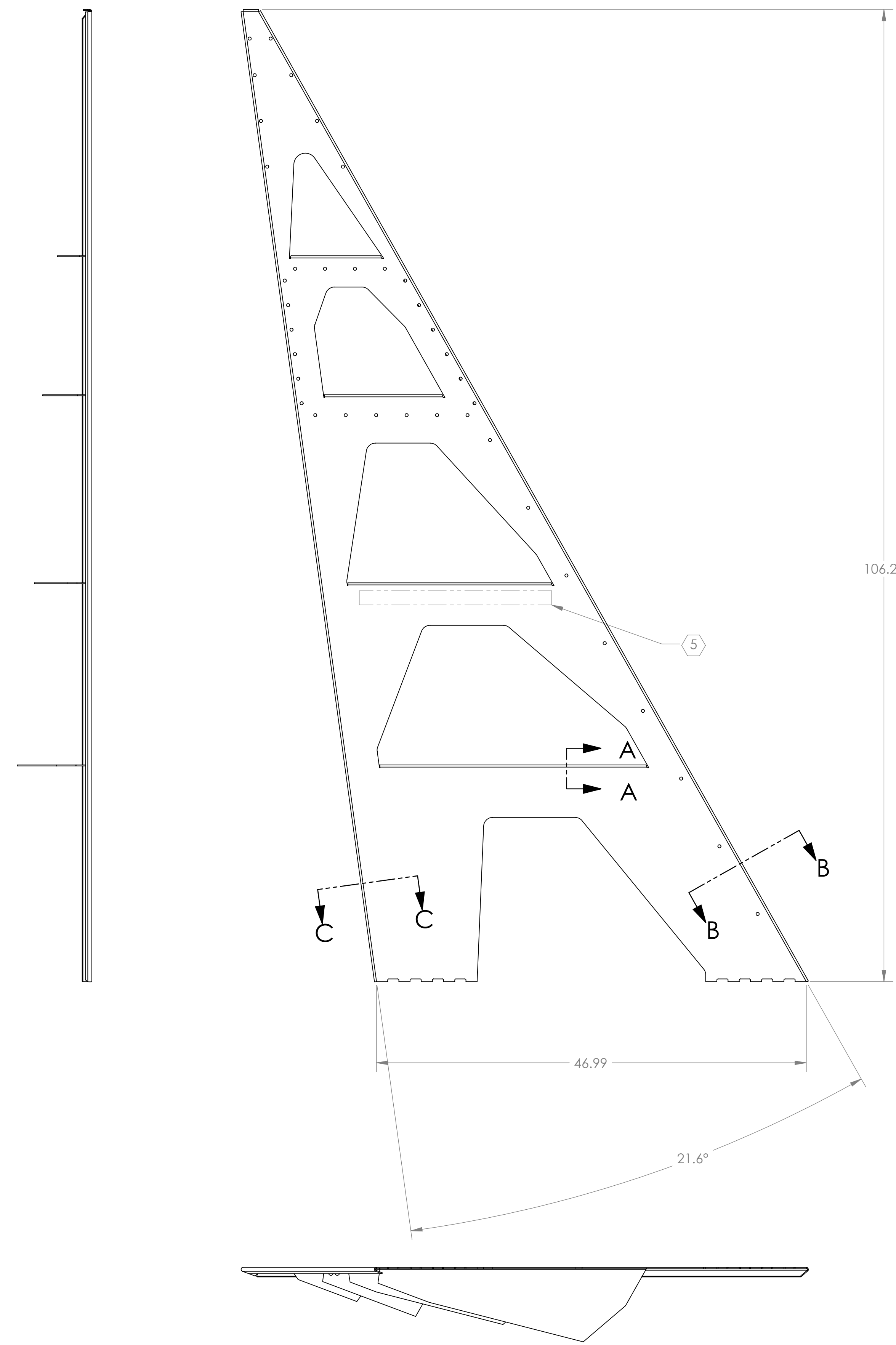

ISO VIEW

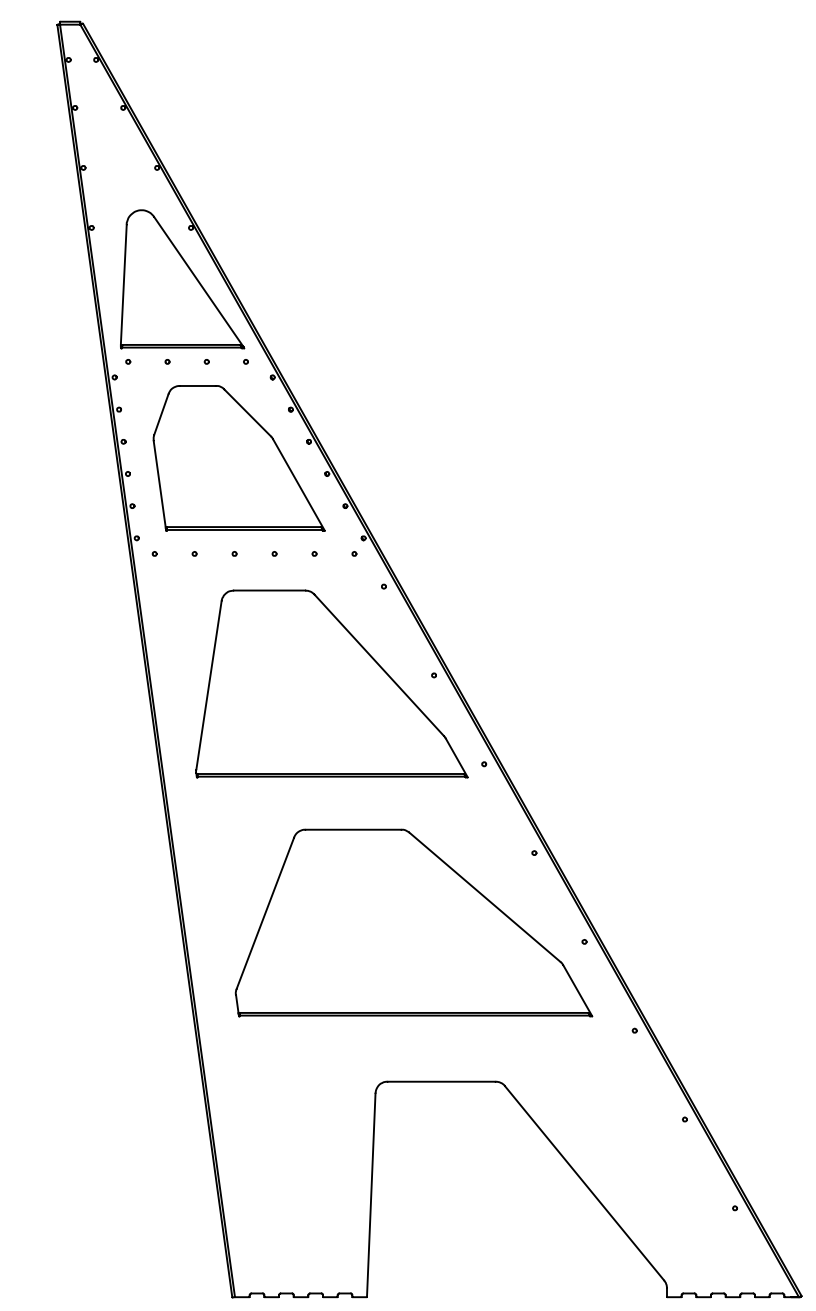

-1

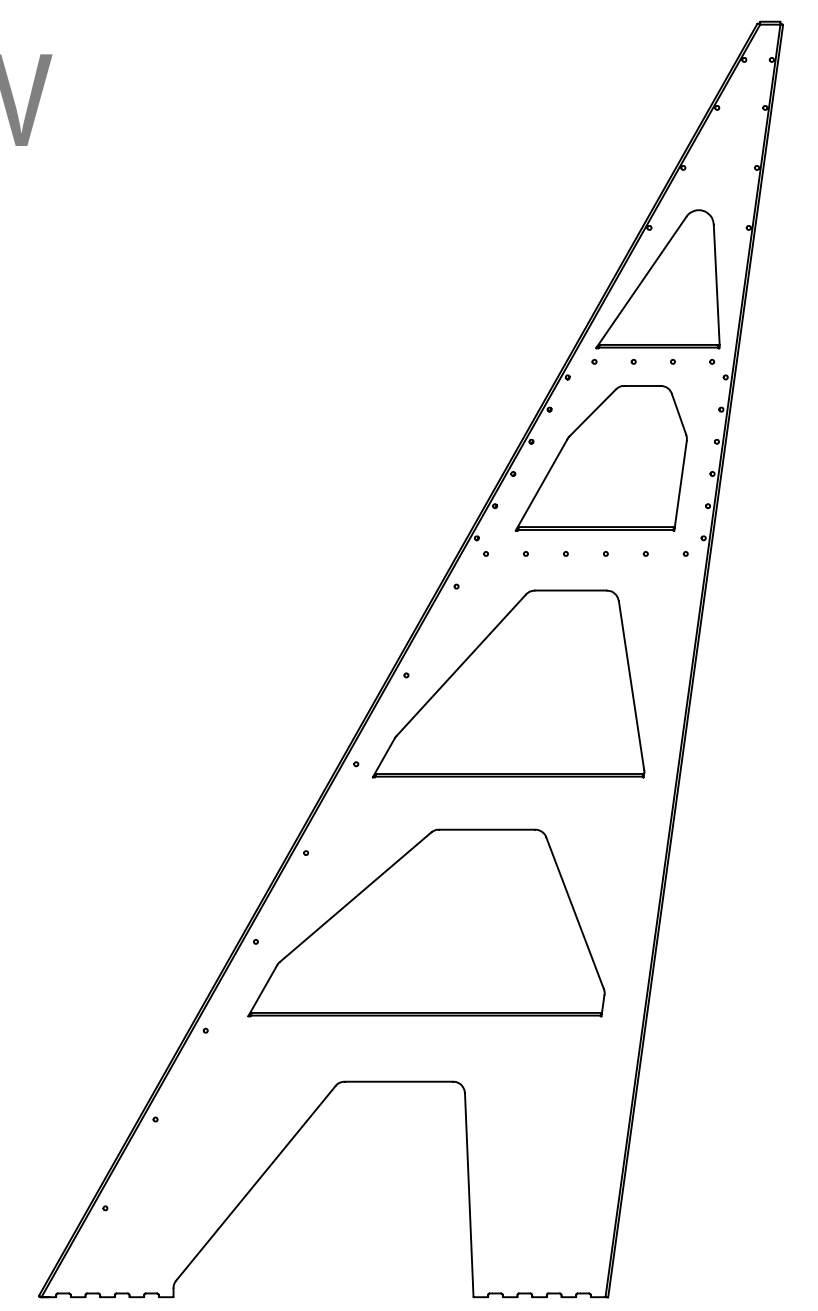

-2

NOTES AND TOLERANCES: (UNLESS OTHERWISE SPECIFIED)	
1. INTERPRET DRAWING PER ASME Y14.5-1994. 2. REMOVE ALL SHARP EDGES, R.02 MIN. 3. DO NOT SCALE FROM DRAWING. 4. ALL MACHINING FLUIDS MUST BE FULLY SYNTHETIC, FULLY WATER SOLUBLE AND FREE OF SULFUR, SILICONE, AND CHLORINE.	
DIMENSIONS ARE IN INCHES TOLERANCES: .XX ± .02 .XXX ± .010 ANGULAR ± 1.0°	MATERIAL: 304 SST SHEET, 12 GAUGE FINISH: 8

<b>LIGO</b> CALIFORNIA INSTITUTE OF TECHNOLOGY MASSACHUSETTS INSTITUTE OF TECHNOLOGY	SYSTEM: ADVANCED LIGO SUB-SYSTEM: AOS NEXT ASSY: D1001325
---	---

PART NAME: ALIGO AOS OPLEV & PHOTCAL RX PIER SIDE PANEL1		DESIGNER: C. CONLEY 16 AUG 2010		SIZE: D	DWG. NO.: D1000594	REV.: v1
DRAFTER: N. KILPATRICK 17 AUG 2010		CHECKER:		APPROVAL:	SCALE: 1:8	PROJECTION:
				SHEET 1 OF 3		

D:\000594\ALIGO AOS Oplev & Photcal RX Pier Side Panel1 (LLO).PART.PDM.REV.X-011.DRAWING.PDM.REV.X-010

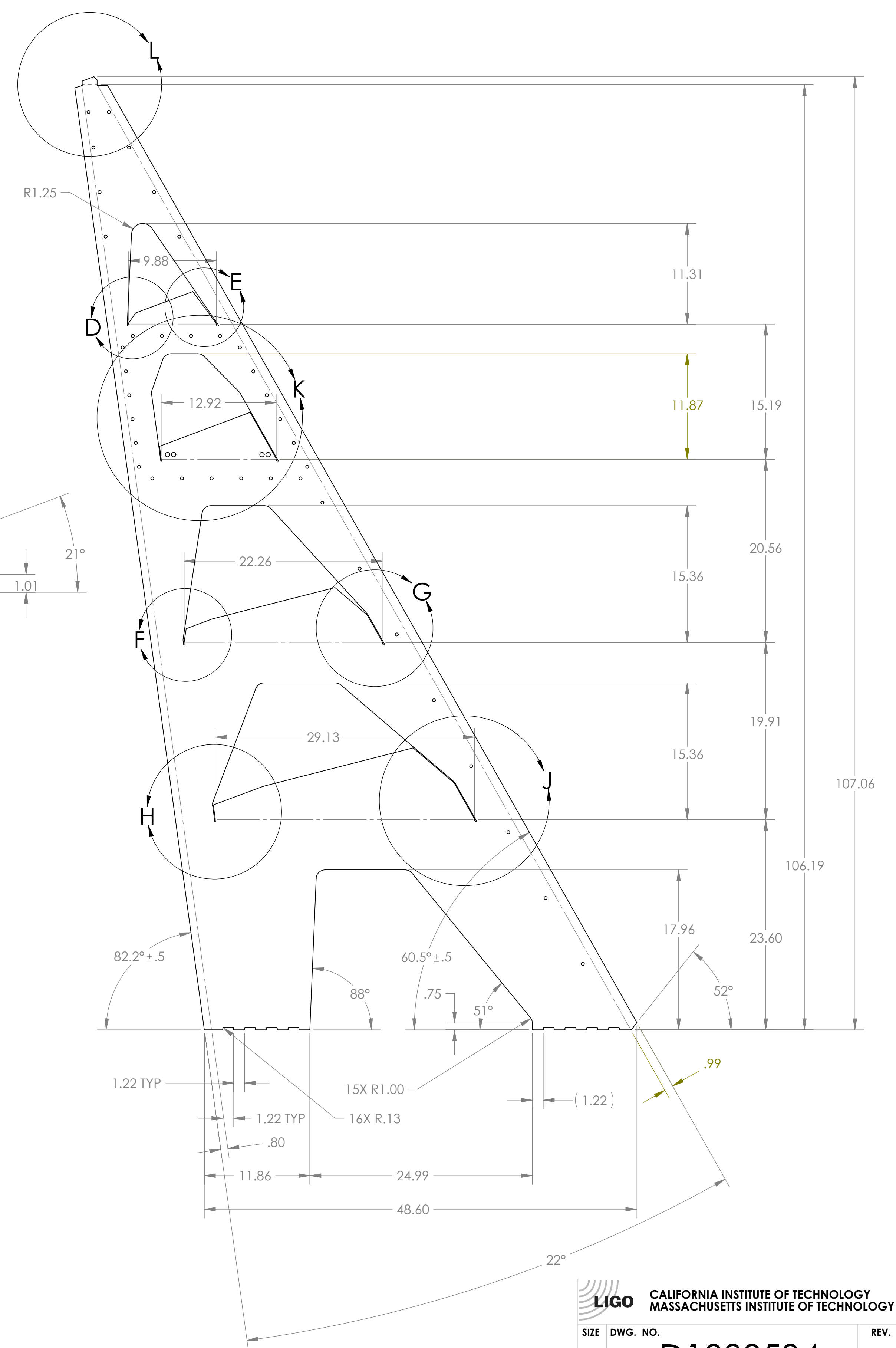
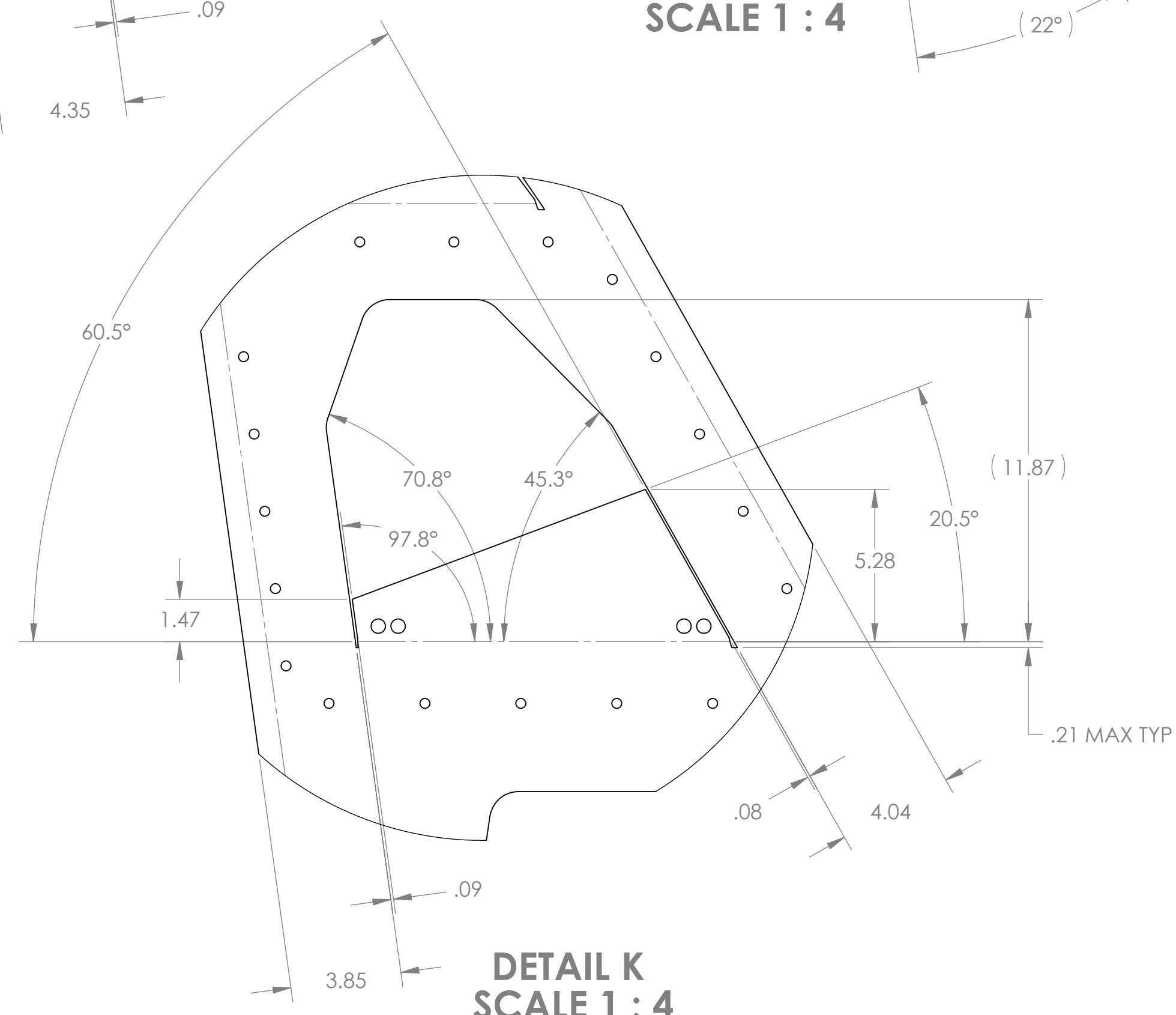
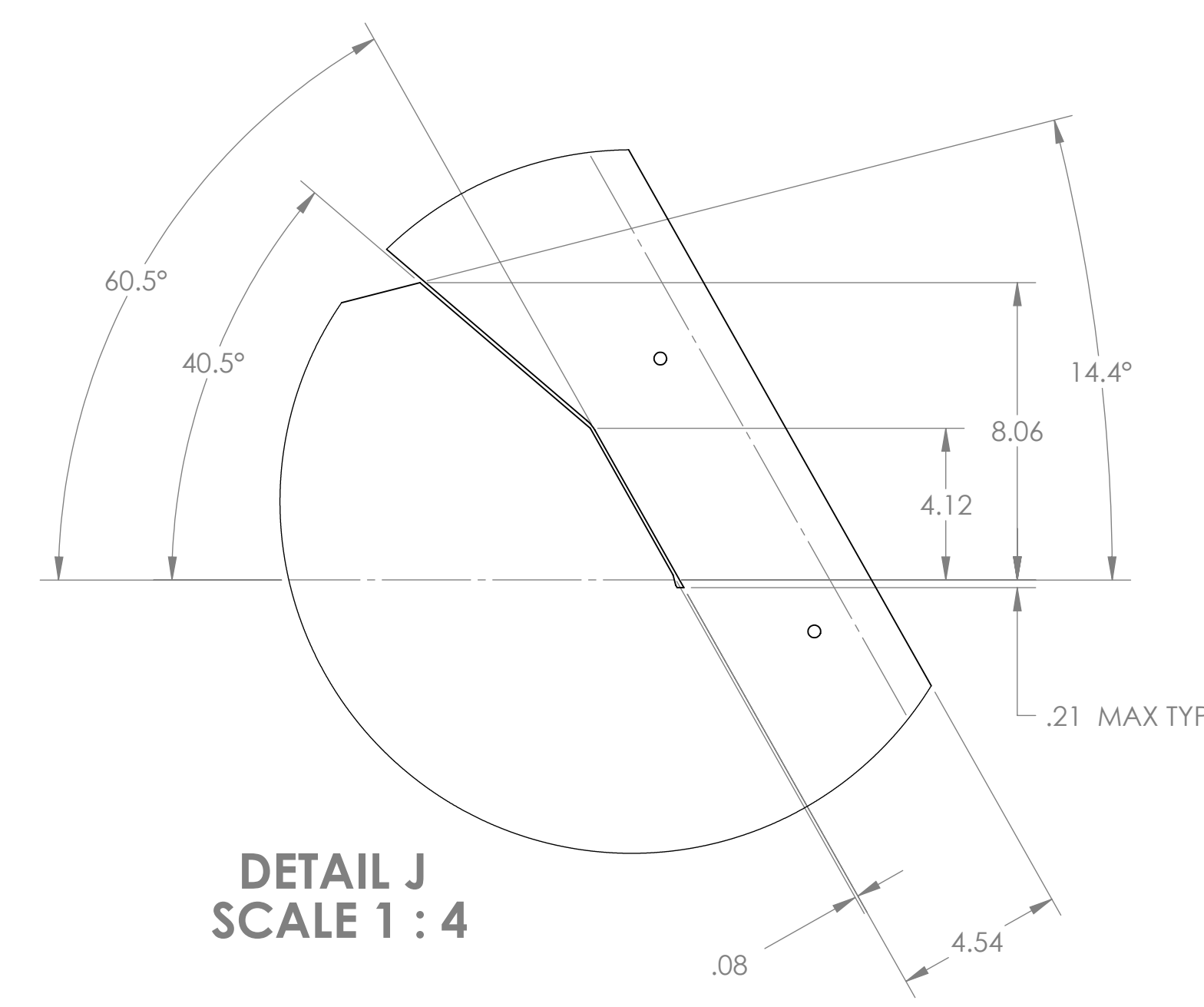
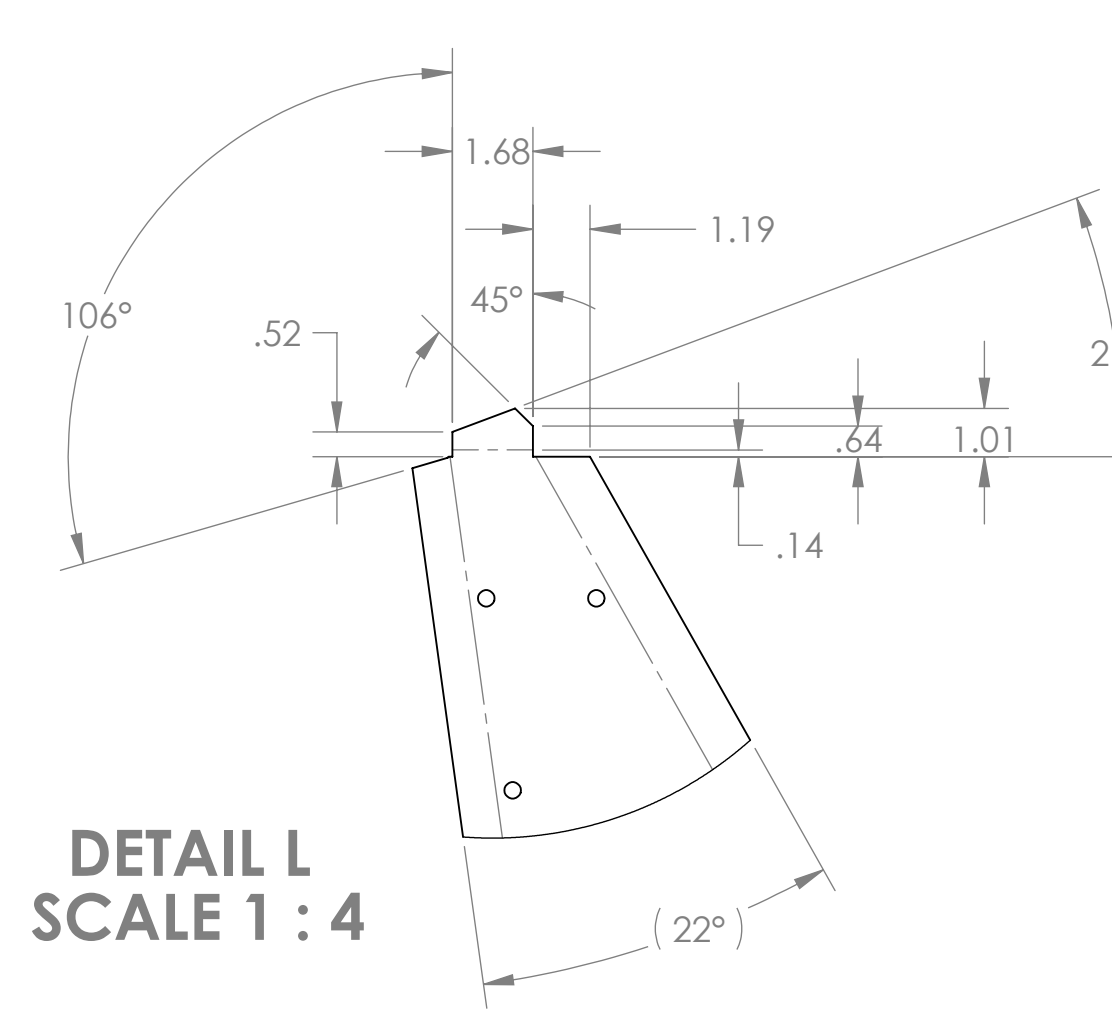
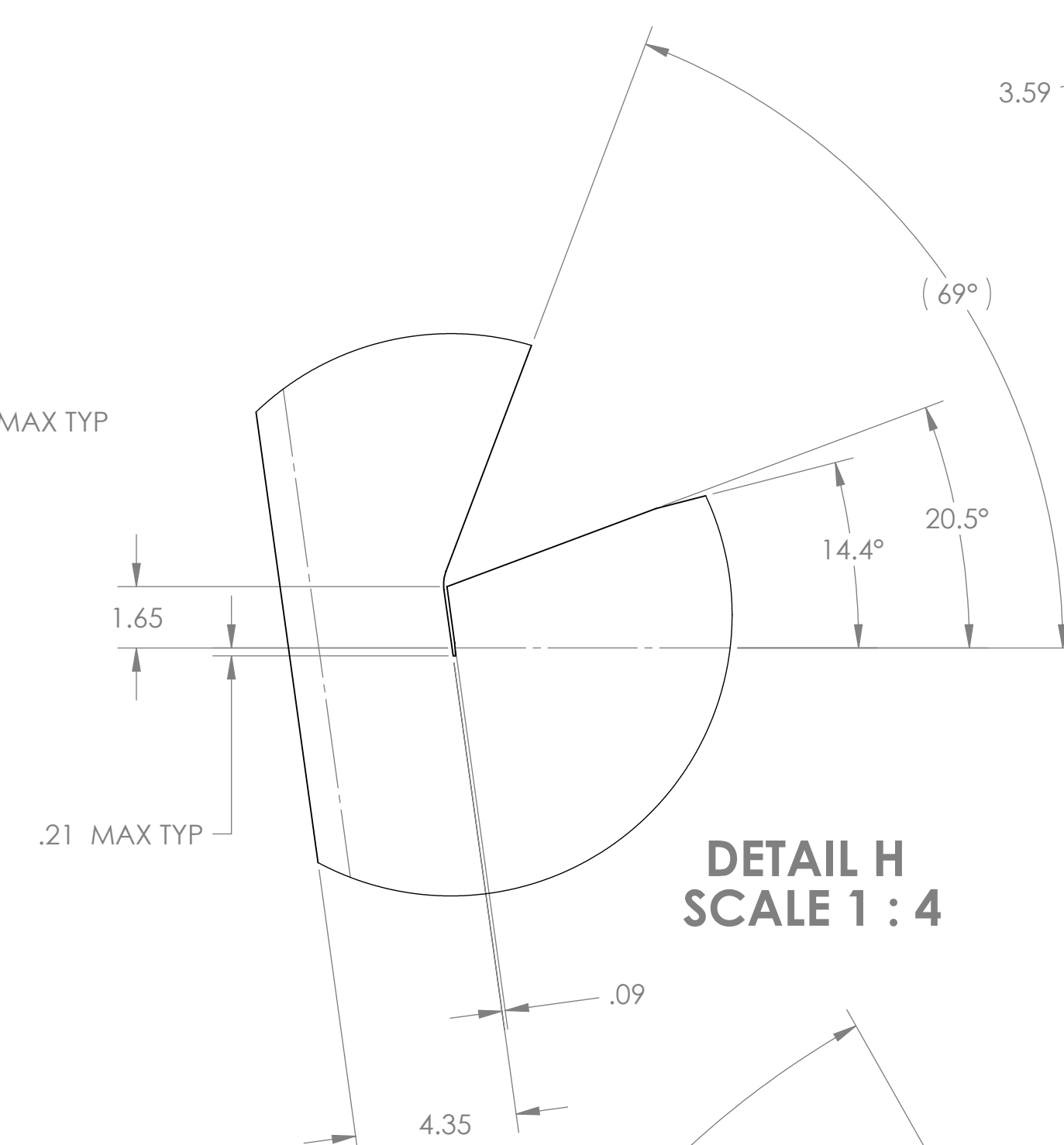
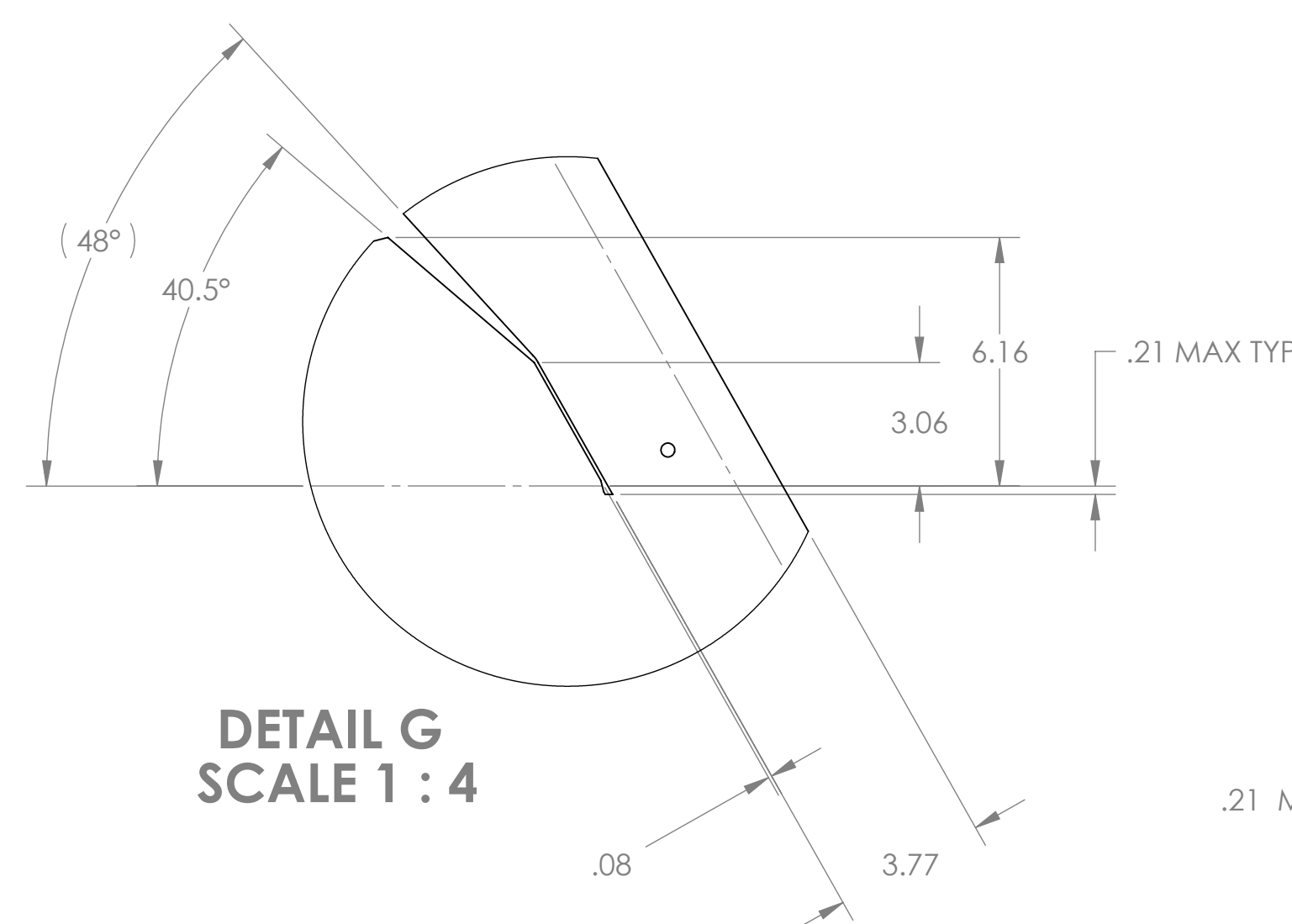
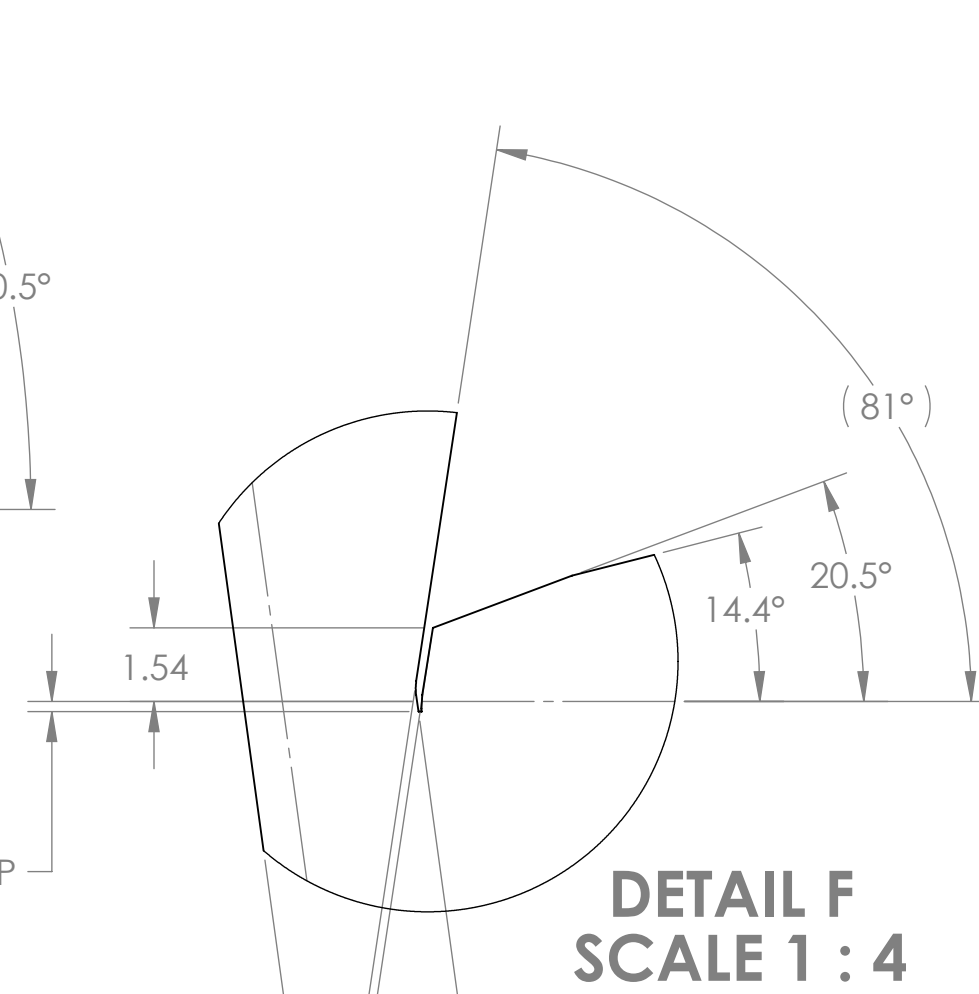
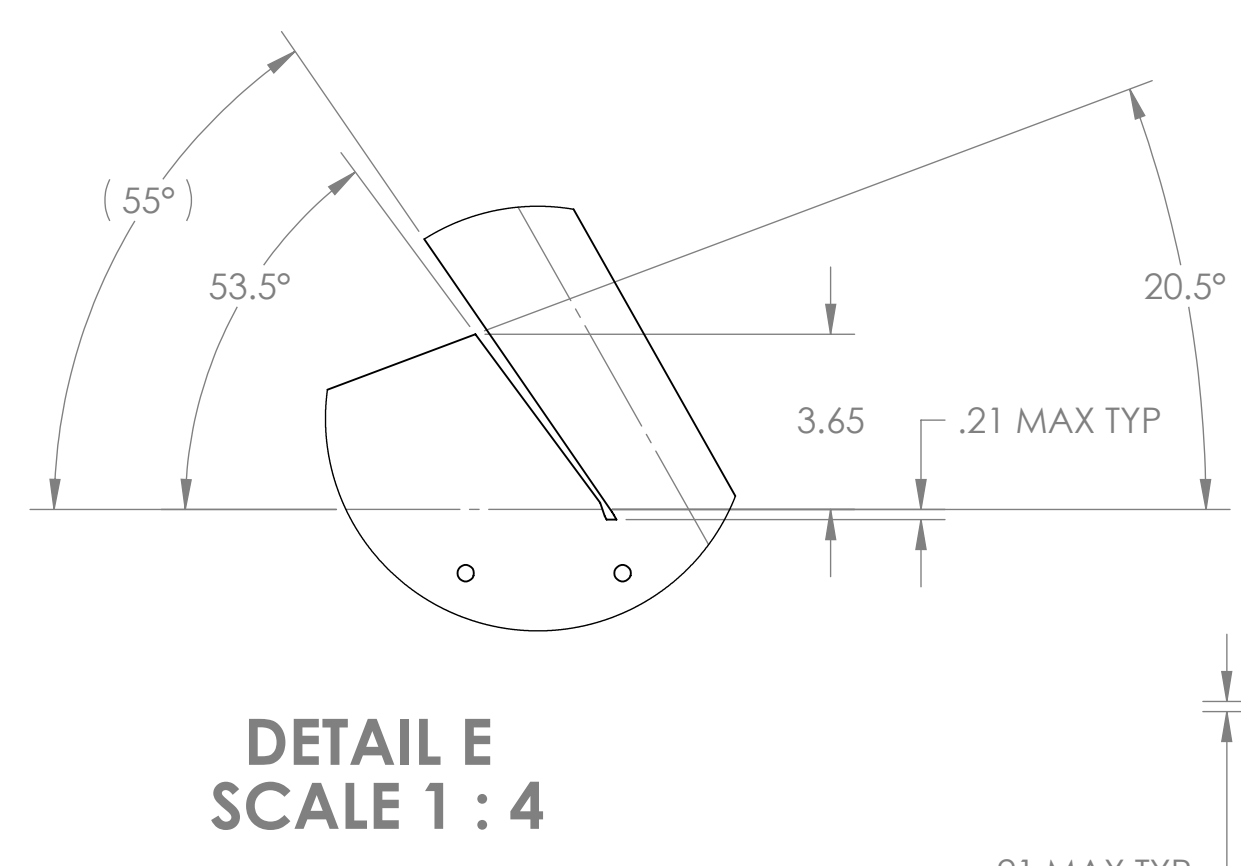
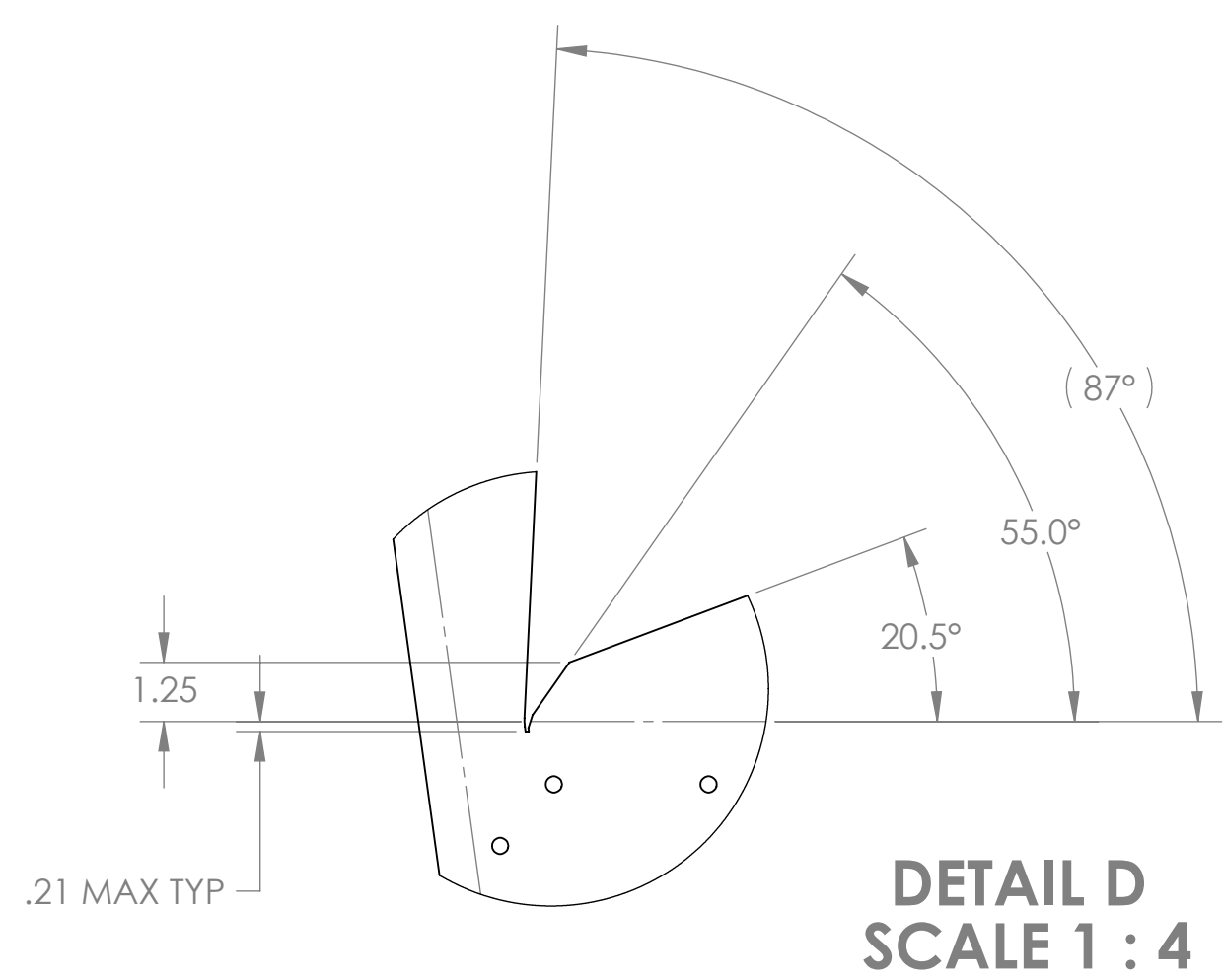
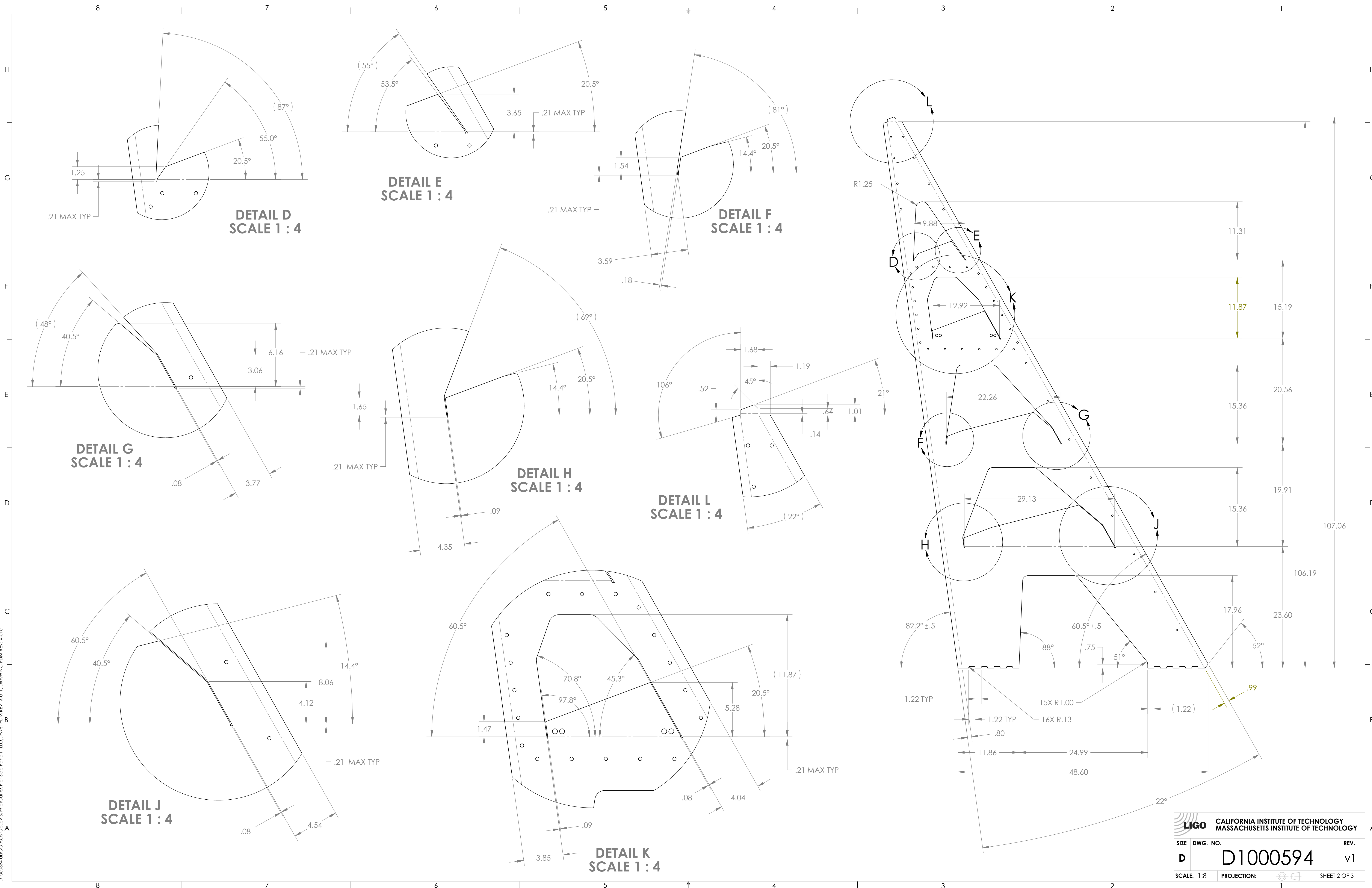

**LIGO** CALIFORNIA INSTITUTE OF TECHNOLOGY  
MASSACHUSETTS INSTITUTE OF TECHNOLOGY

SIZE	DWG. NO.	REV.
D	D1000594	v1
SCALE: 1:8	PROJECTION:	SHEET 2 OF 3

D:\000974\ligo\ACS\_Octave & PhIC\CA\_PX\_Per Side Panel\ [LOI]\_PART\_PDM\_REV.X-011\_DRAWING\_PDM\_REV.X-010

8 7 6 5 4 3 2 1

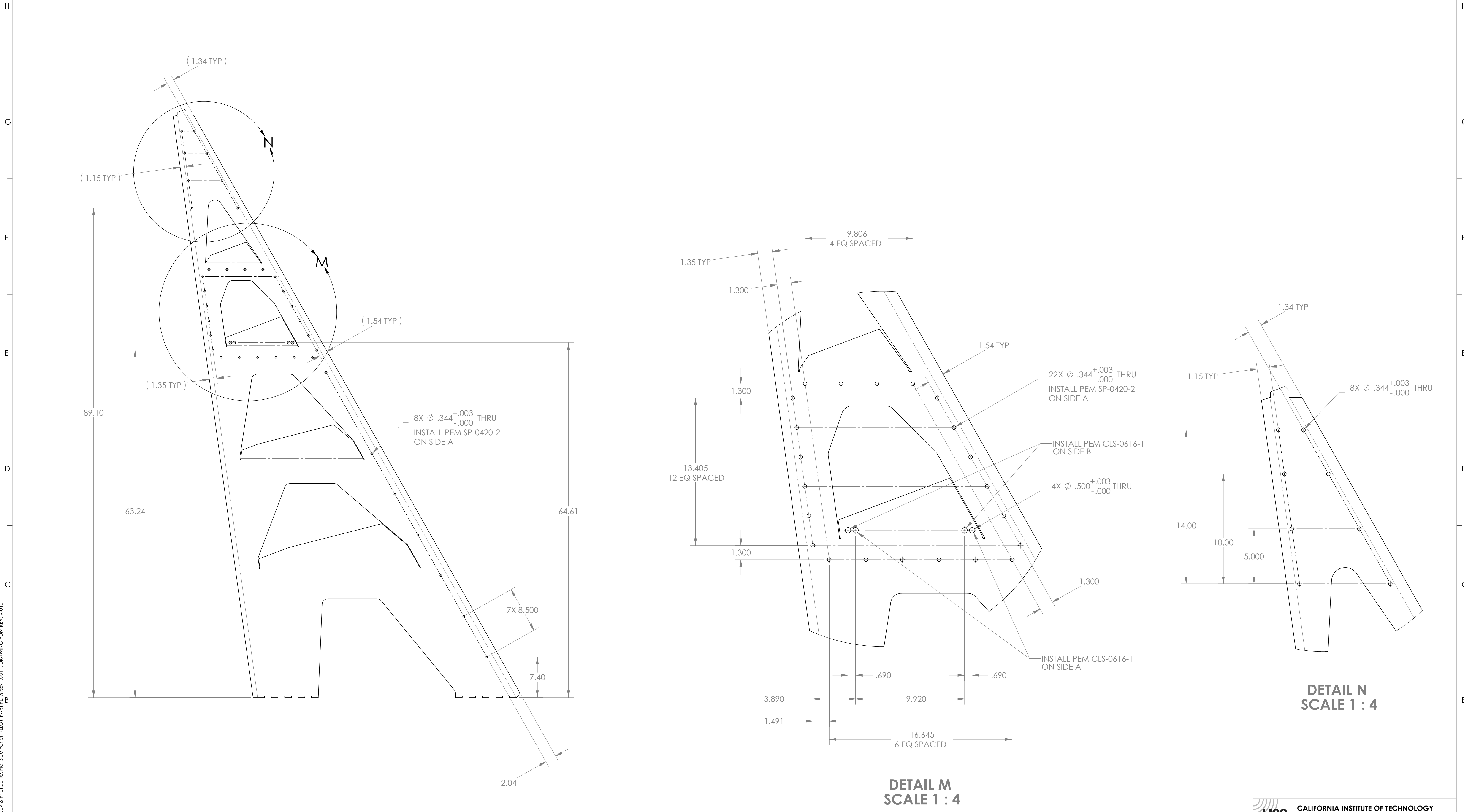

DETAIL M  
SCALE 1 : 4

DETAIL N  
SCALE 1 : 4

<b>LIGO</b> CALIFORNIA INSTITUTE OF TECHNOLOGY MASSACHUSETTS INSTITUTE OF TECHNOLOGY	
SIZE DWG. NO.	REV.
<b>D</b> <b>D1000594</b>	<b>v1</b>
SCALE: 1:8	PROJECTION:
SHEET 3 OF 3	

D:\00594\dl\GCO\_ACS\_Octave & PhotoCat\_RX\_Per Side Panel1 ([LO])\_PART\_PDM\_REV-X-011.DRAWING PDM\_REV-X-010

- NOTES CONTINUED:**
- ⑤ SCRIBE, ENGRAVE, OR MECHANICALLY STAMP (NO INKS OR DYES) DRAWING PART NUMBER AND REVISION ON NOTED SURFACE FOLLOWED ON THE NEXT LINE BY A THREE DIGIT SERIAL NUMBER. SERIAL NUMBERS START AT 001 FOR THE FIRST ARTICLE AND PROCEED CONSECUTIVELY. USE .07" HIGH CHARACTERS. EXAMPLE: DXXXXX-VV, S/N 001. VIBRATORY TOOL MAY BE USED.
  - 6. DO NOT DEBURR HOLES.
  - ⑦ FOR BOTH -1 & -2, SIDE A IS SIDE TOWARD FOLDS.
  - ⑧ STOCK FINISH/AS RECEIVED.
  - ⑨ ADDED MATERIAL TO BE HELD TO INDICATED DIMENSIONS. FLATNESS TO BE MAINTAINED TO .030 BETWEEN JOINED PIECES.

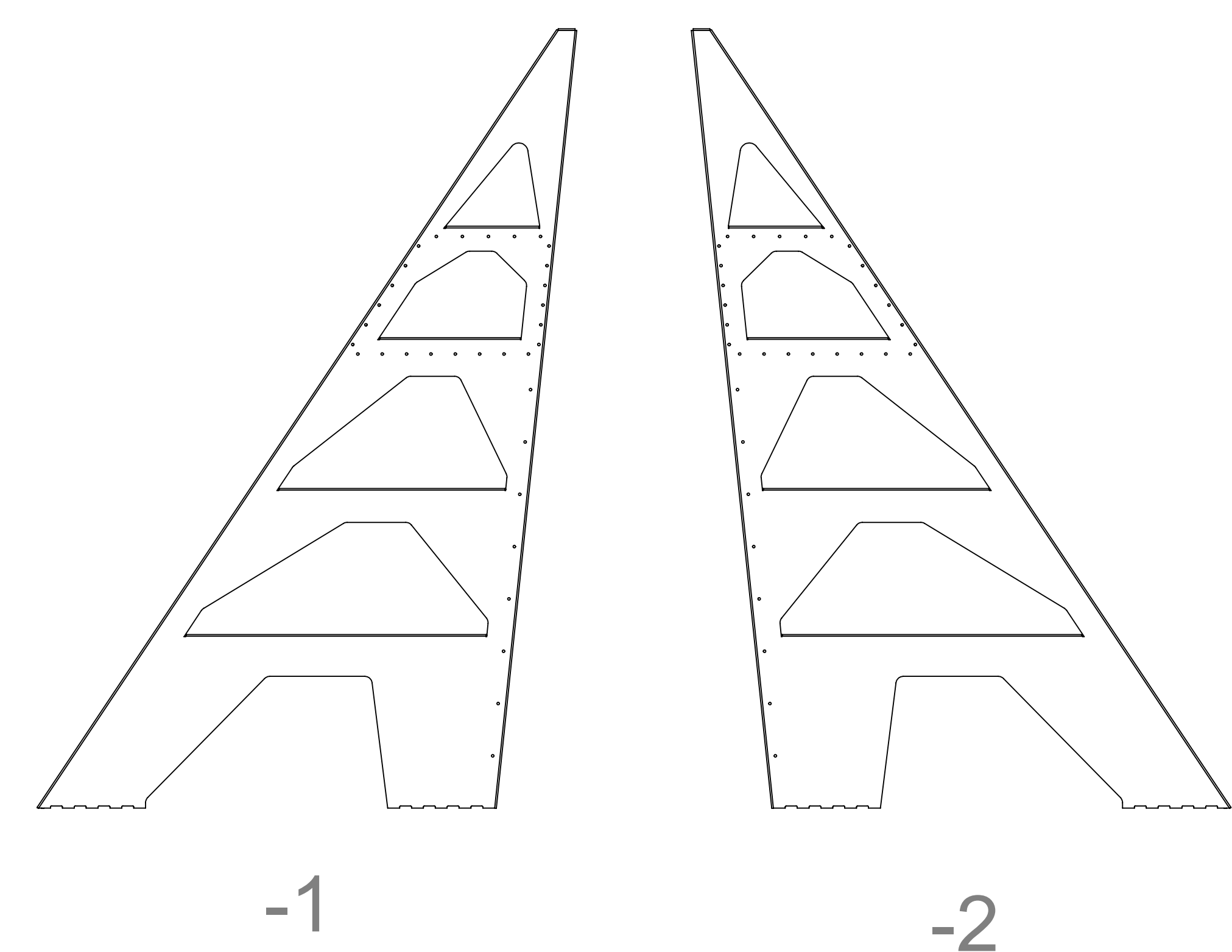
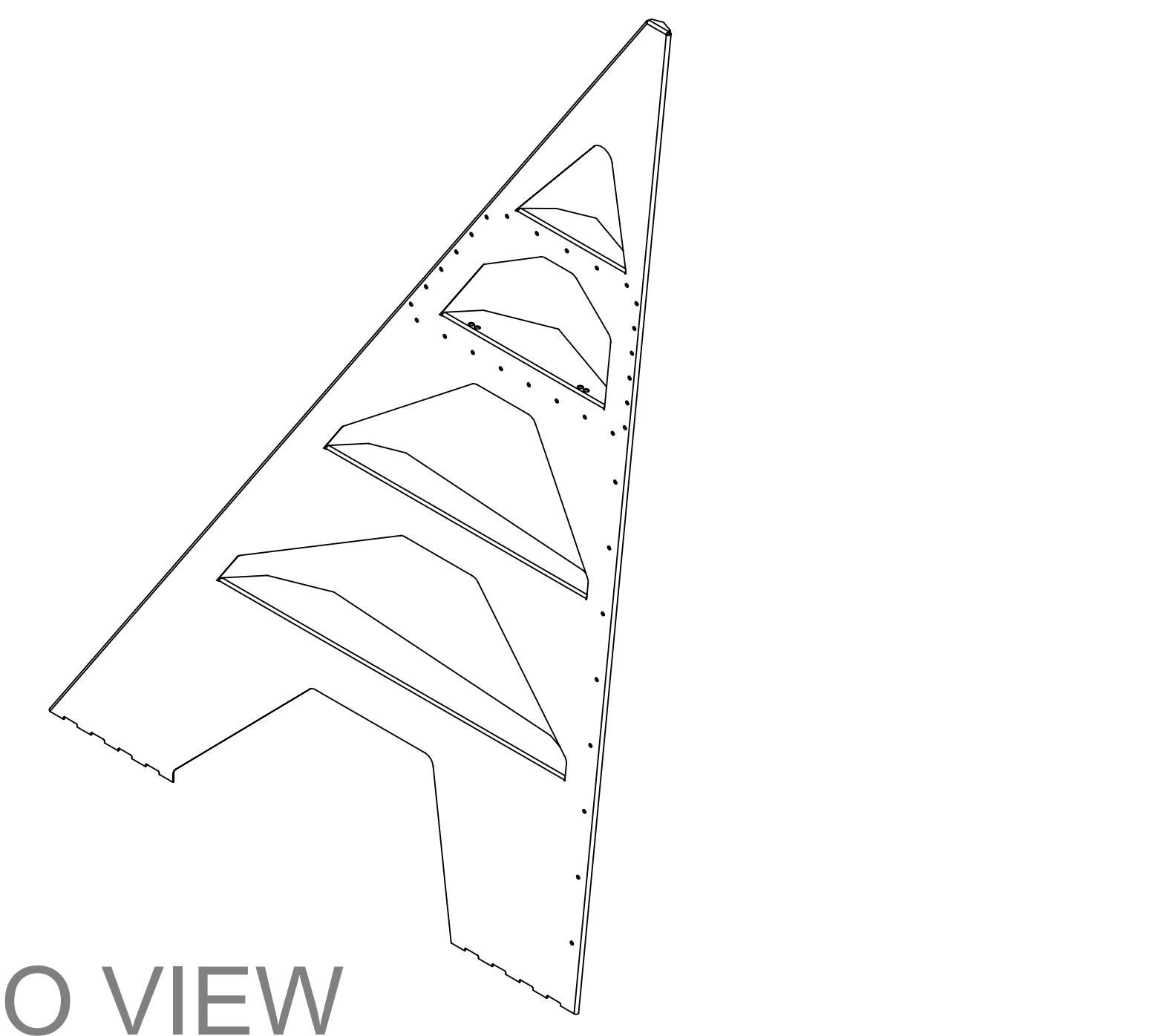
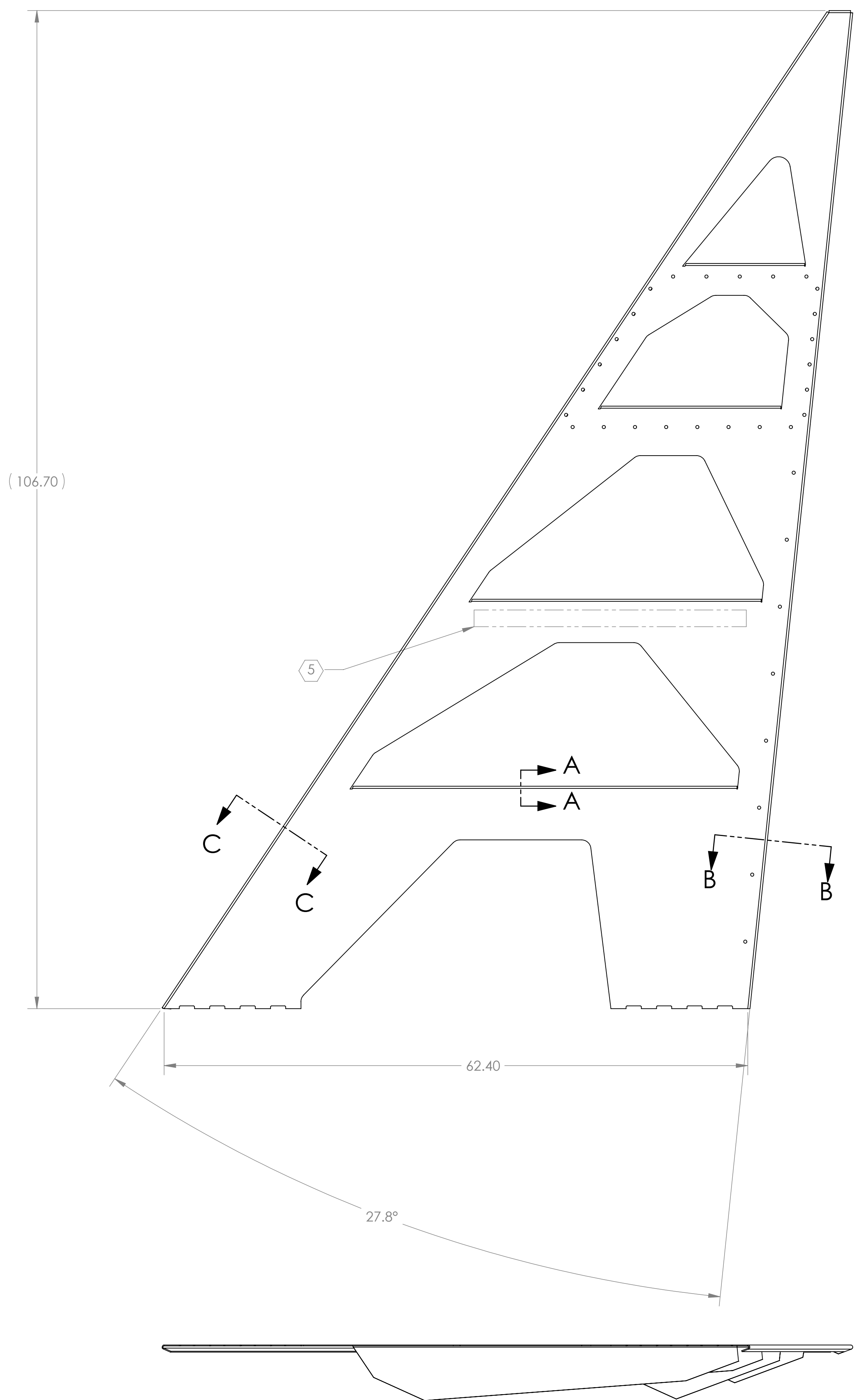
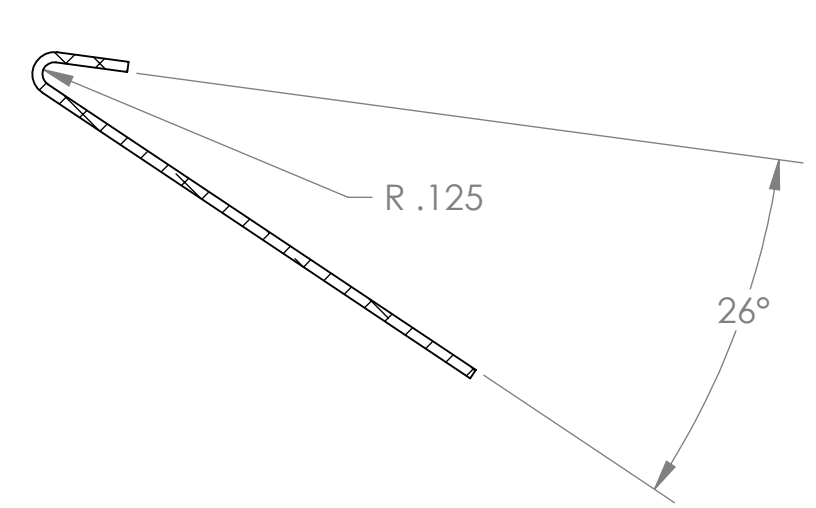
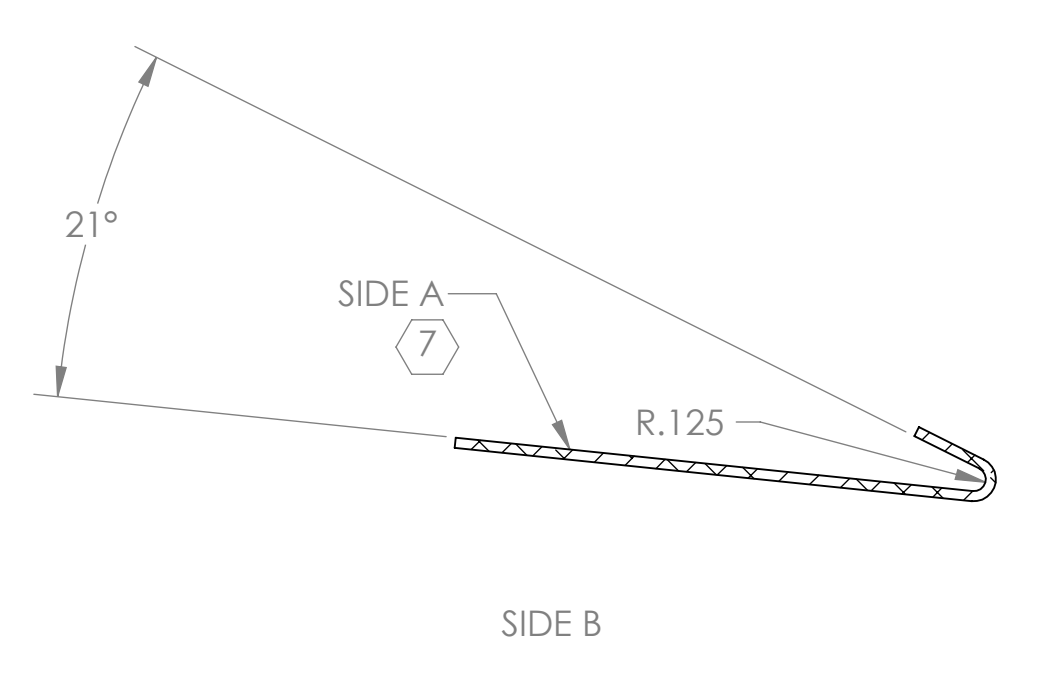
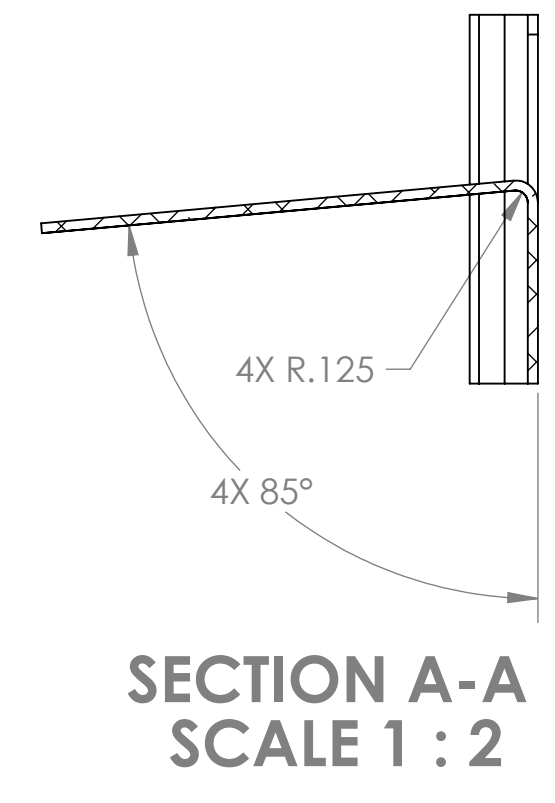

REV.	DATE	DCN #	DRAWING TREE #
v1	17 AUGUST 2010	E1000182-v1	-
v2	2 DEC 2010	E1000182-v2	-
-	-	-	-

NOTES AND TOLERANCES: (UNLESS OTHERWISE SPECIFIED)		LIGO CALIFORNIA INSTITUTE OF TECHNOLOGY MASSACHUSETTS INSTITUTE OF TECHNOLOGY		PART NAME	
DIMENSIONS ARE IN INCHES TOLERANCES: .XX ± .01 .XXX ± .005 ANGULAR ± 1.0°		1. INTERPRET DRAWING PER ASME Y14.5-1994. 2. REMOVE ALL SHARP EDGES, R.02 MIN. 3. DO NOT SCALE FROM DRAWING. 4. ALL MACHINING FLUIDS MUST BE FULLY SYNTHETIC, FULLY WATER SOLUBLE AND FREE OF SULFUR, SILICONE, AND CHLORINE.		<b>ALIGO AOS OPLEV &amp; PHOTCAL RX PIER SIDE PANEL2</b>	
MATERIAL	FINISH	SYSTEM	SUB-SYSTEM	DESIGNER	DATE
304 SSSL SHEET, 12 GAUGE	⑧	ADVANCED LIGO	AOS	C. CONLEY	16 AUG 2010
		NEXT ASSY		DRAFTER	DATE
		D1001325		N. KILPATRICK	17 AUG 2010
				CHECKER	
				APPROVAL	
				SIZE	DWG. NO.
				D	D1000595
				SCALE: 1:8	PROJECTION:
					SHEET 1 OF 3
				REV.	v2

D1000595.dwg: AOS Oplev & Photcal RX Pier Side Panel2 (ILO), PART PDM REV: X-005, DRAWING PDM REV: X-014



8 7 6 5 4 3 2 1

H  
G  
F  
E  
D  
C  
B  
A

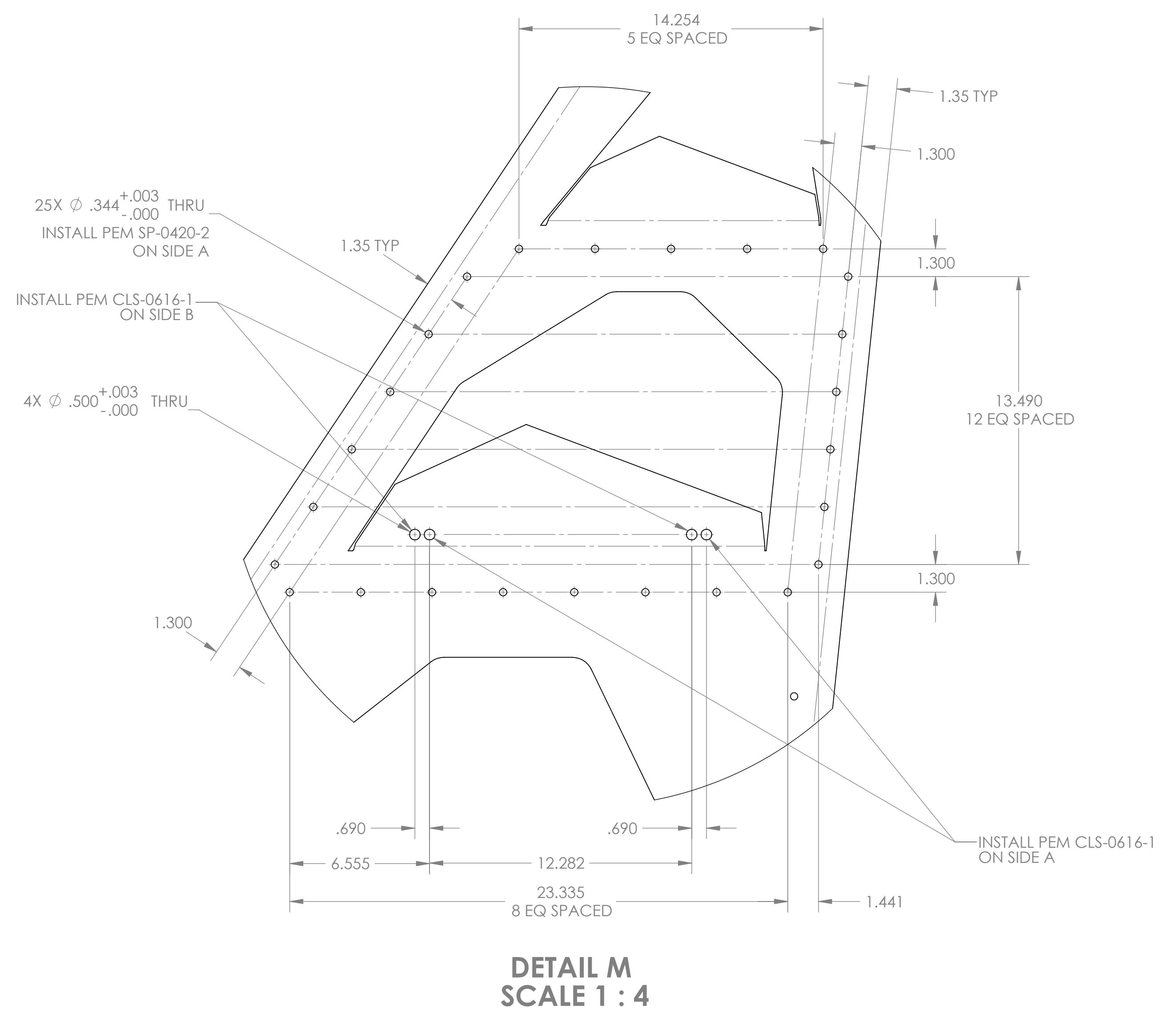
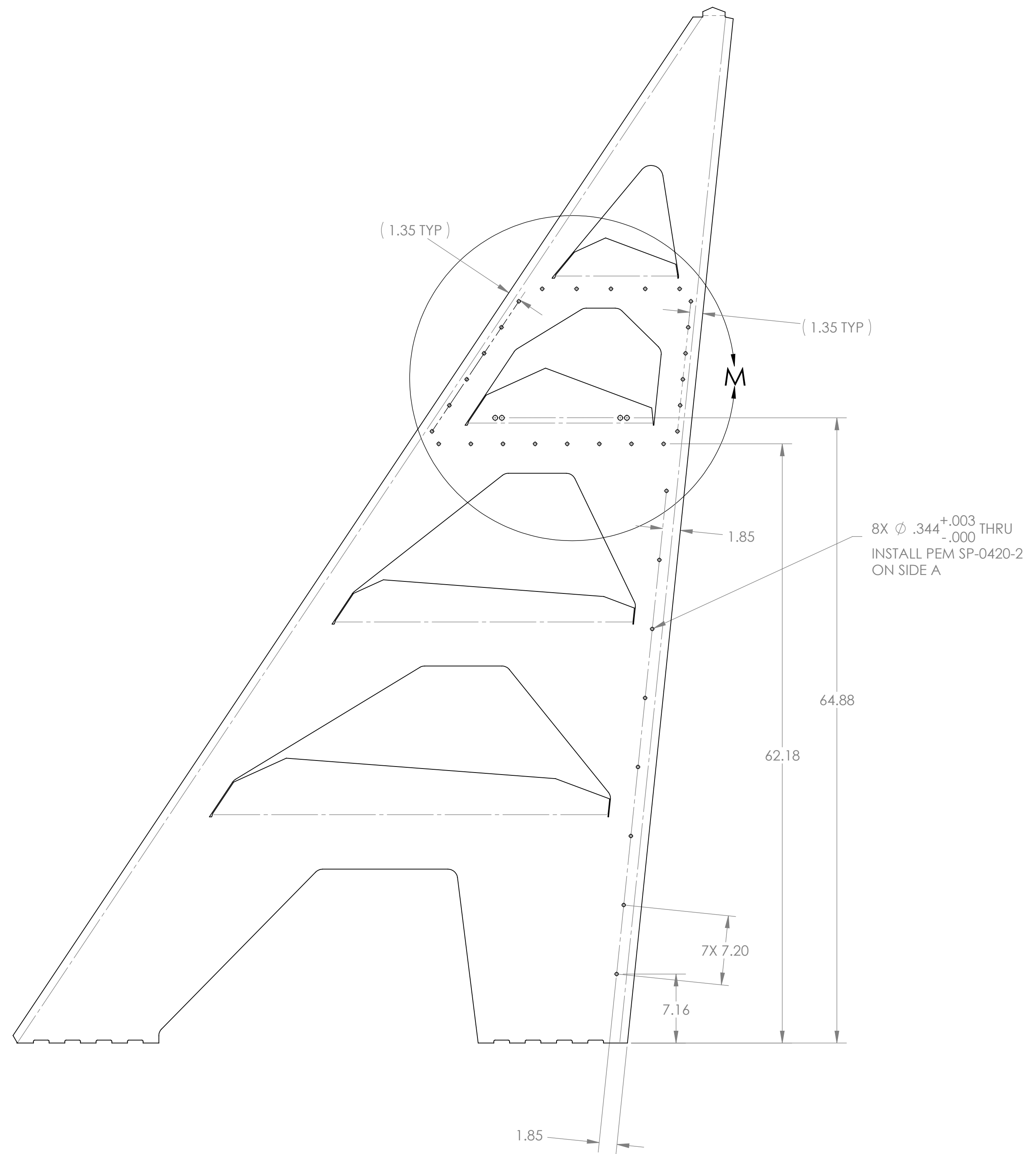

FLAT PATTERN

<b>LIGO</b> CALIFORNIA INSTITUTE OF TECHNOLOGY MASSACHUSETTS INSTITUTE OF TECHNOLOGY	
SIZE DWG. NO.	REV.
D D1000595	v2
SCALE: 1:8	PROJECTION:
SHEET 3 OF 3	

D:\000595\ligo\ACS\Ocleve & Photo\ligo\RX\Per Side Panel2 (LLO).PART.PDM.REV.X-905.DRAWING.PDM.REV.X-014

8 7 6 5 4 3 2 1

**NOTES CONTINUED:**  
 5. SCRIBE, ENGRAVE, OR MECHANICALLY STAMP (NO INKS OR DYES) DRAWING PART NUMBER, REVISION (AND VARIANT OR TYPE IF APPLICABLE) ON NOTED SURFACE OF PART FOLLOWED ON THE NEXT LINE WITH A THREE DIGIT SERIAL NUMBER. SERIAL NUMBERS START AT 001 FOR THE FIRST ARTICLE AND PROCEED CONSECUTIVELY. USE MINIMUM 0.12" HIGH CHARACTERS, UNLESS THE SIZE OF THE PART DICTATES SMALLER CHARACTERS. A VIBRATORY TOOL MAY BE USED. EXAMPLE: DXXXXXX-VY, TYPE-XX, S/N XXX

6. DO NOT DEBURR HOLES.  
 7. FOR BOTH -1 & -2, SIDE A IS SIDE TOWARD FOLDS.  
 8. STOCK FINISH/AS RECEIVED.

REV.	DATE	DCN #	DRAWING TREE #
v1	17 AUGUST 2010	E1000182-v1	-
-	-	-	-
-	-	-	-

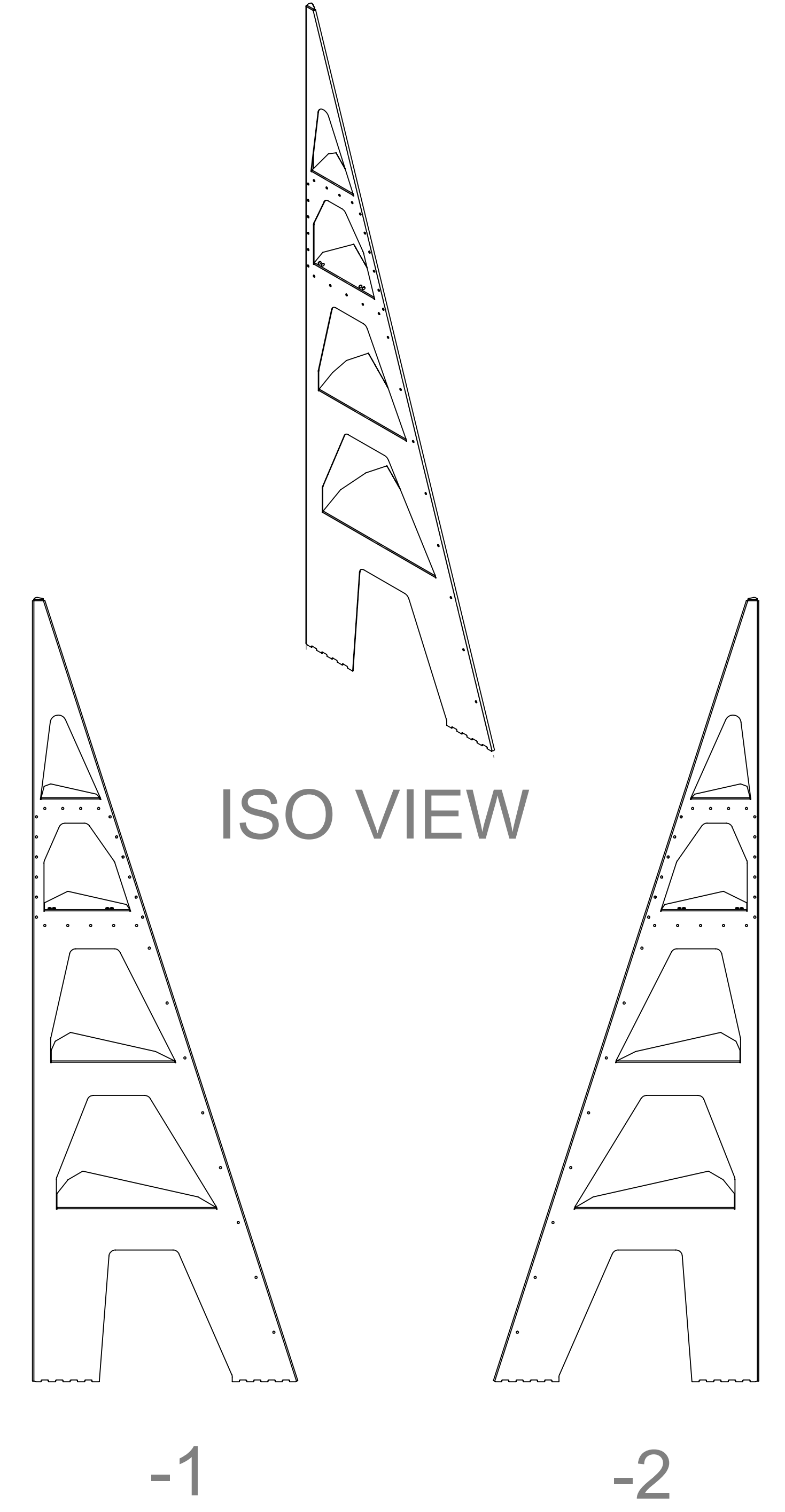
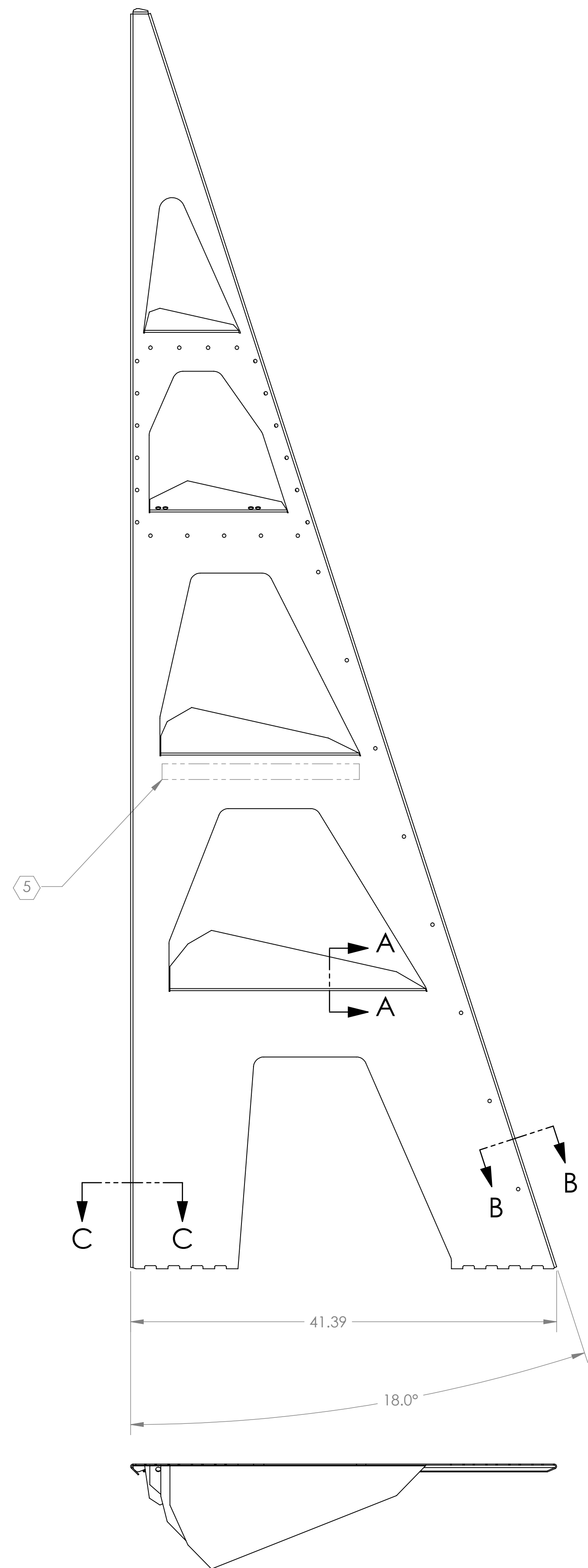
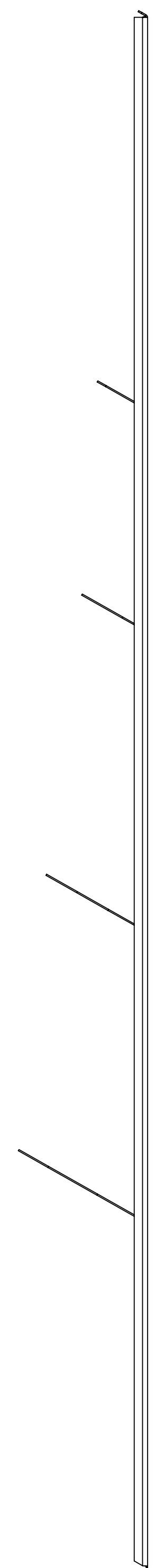
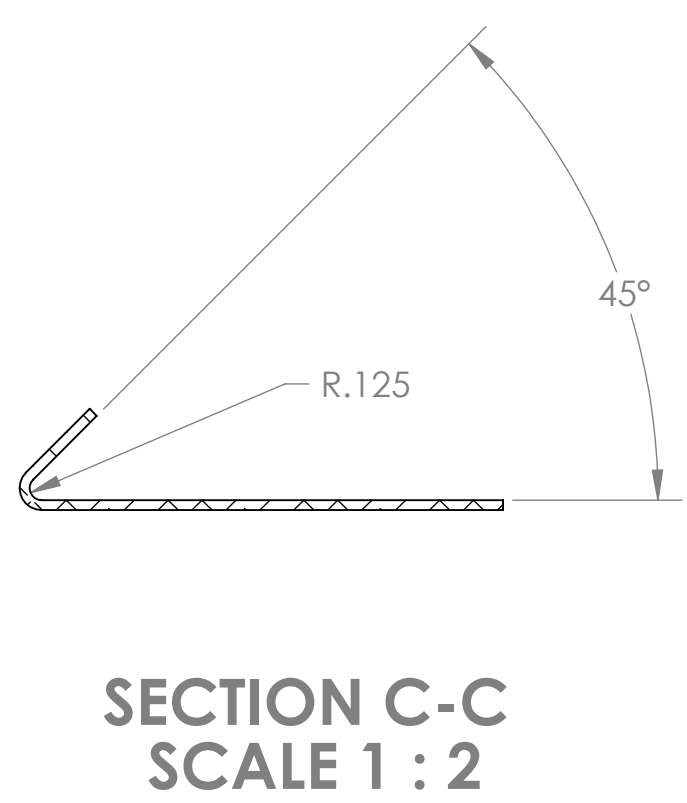
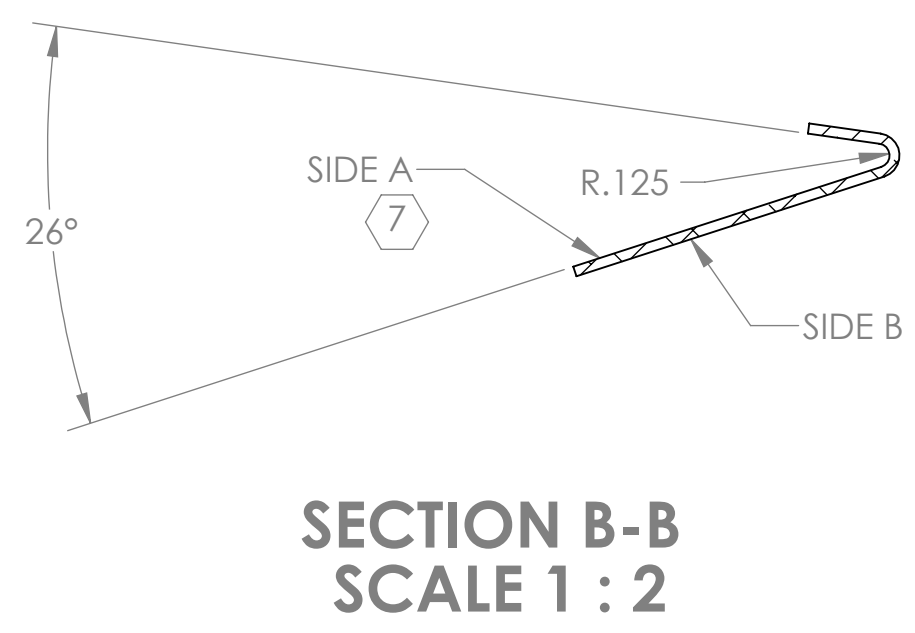
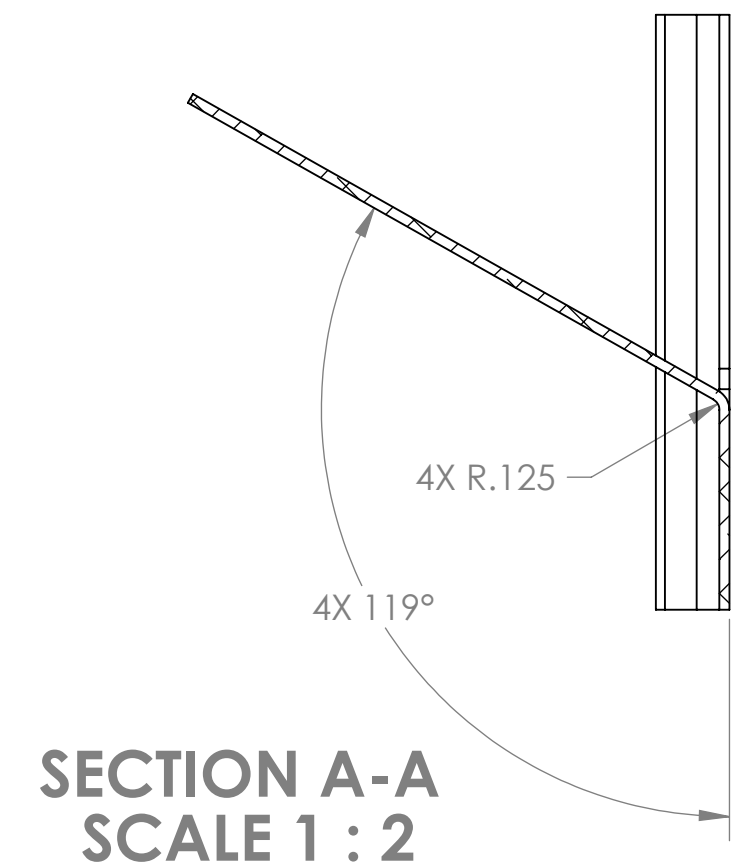

NOTES AND TOLERANCES: (UNLESS OTHERWISE SPECIFIED)		LIGO CALIFORNIA INSTITUTE OF TECHNOLOGY MASSACHUSETTS INSTITUTE OF TECHNOLOGY		PART NAME	
DIMENSIONS ARE IN INCHES TOLERANCES: .XX ± .02 .XXX ± .010 ANGULAR ± 1.0°		1. INTERPRET DRAWING PER ASME Y14.5-1994. 2. REMOVE ALL SHARP EDGES, R.02 MIN. 3. DO NOT SCALE FROM DRAWING. 4. ALL MACHINING FLUIDS MUST BE FULLY SYNTHETIC, FULLY WATER SOLUBLE AND FREE OF SULFUR, SILICONE, AND CHLORINE.		<b>ADVANCED LIGO</b> <b>AOS</b>	
<b>MATERIAL</b> 304 SSSL SHEET, 12 GAUGE		<b>FINISH</b> (8)		<b>NEXT ASSY</b> D1001325	
		<b>DESIGNER</b> C. CONLEY      16 AUG 2009 <b>DRAFTER</b> N. KILPATRICK      17 AUG 2010 <b>CHECKER</b> <b>APPROVAL</b>		<b>SIZE</b> D <b>DWG. NO.</b> D1000596 <b>REV.</b> v1	
		<b>SCALE:</b> 1:16 <b>PROJECTION:</b>		<b>SHEET 1 OF 3</b>	

-1	AS DETAILED
-2	ALL BENDS OPPOSITE TO DETAILED

D:\000975\dlUGO AOS Oplev & PhotCAL RX Pier Side Panel3 (L10).PART.PDM.REV.X-008.DRAWING.PDM.REV.X-005



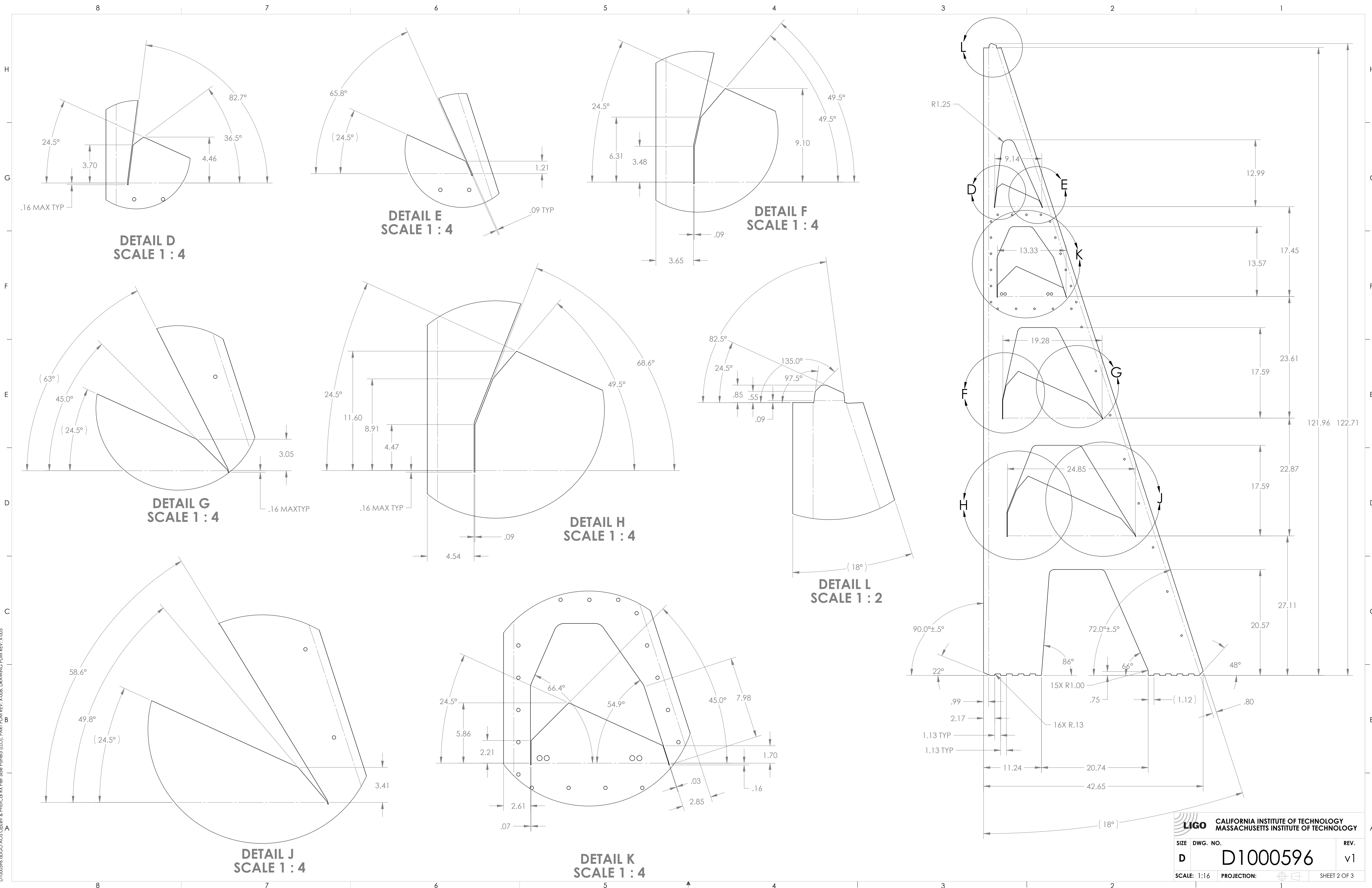

D:\000596\01\000596.dwg ACS Octave & PhotoCAD RX Per Side Pinned (LLO).PART.PDM.REV.X-208.DRAWING.PDM.REV.X-005

<b>LIGO</b> CALIFORNIA INSTITUTE OF TECHNOLOGY MASSACHUSETTS INSTITUTE OF TECHNOLOGY	
SIZE DWG. NO.	REV.
<b>D</b>	<b>D1000596</b>
SCALE: 1:16	PROJECTION:  SHEET 2 OF 3

8 7 6 5 4 3 2 1

H G F E D C B A

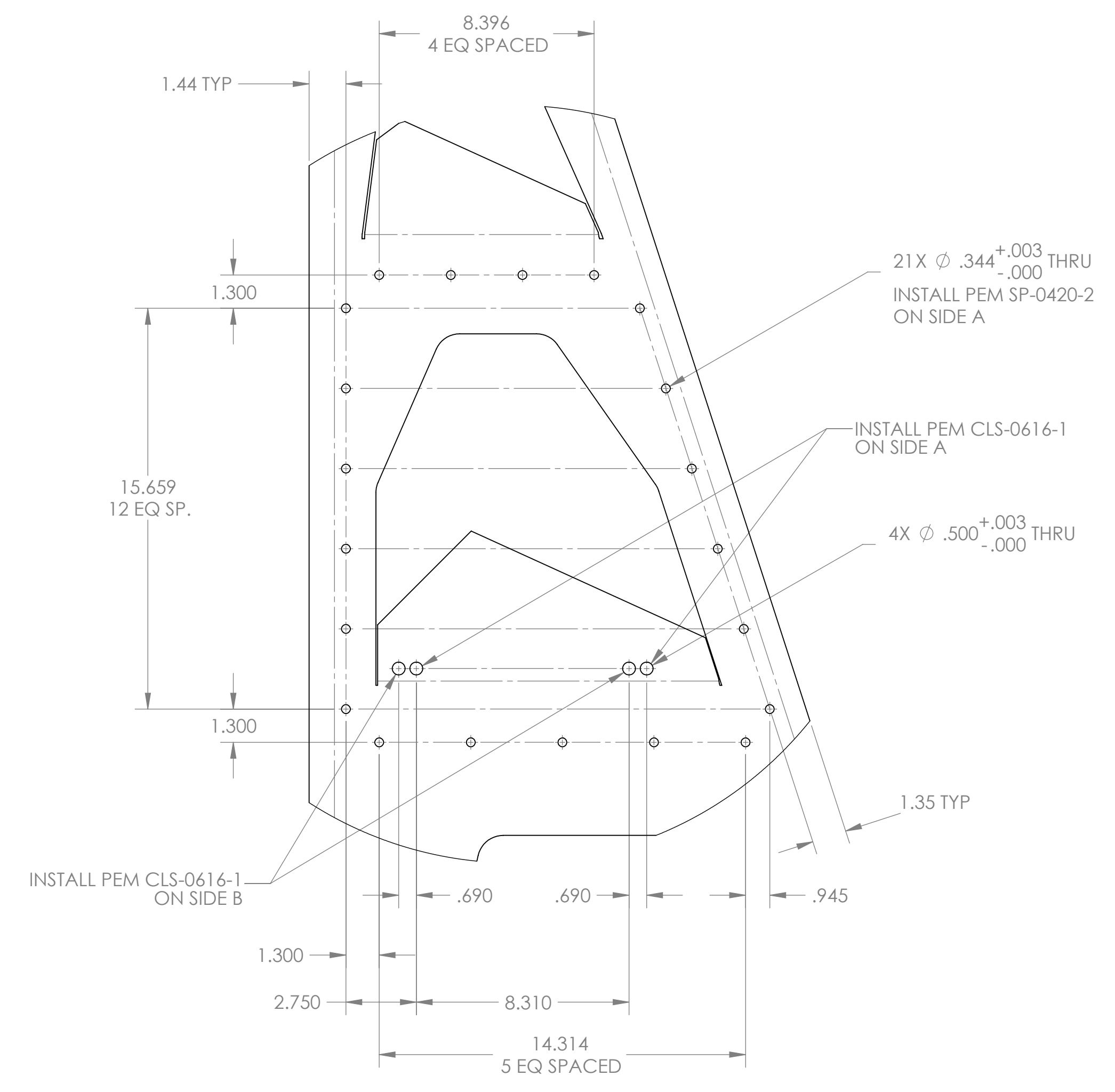
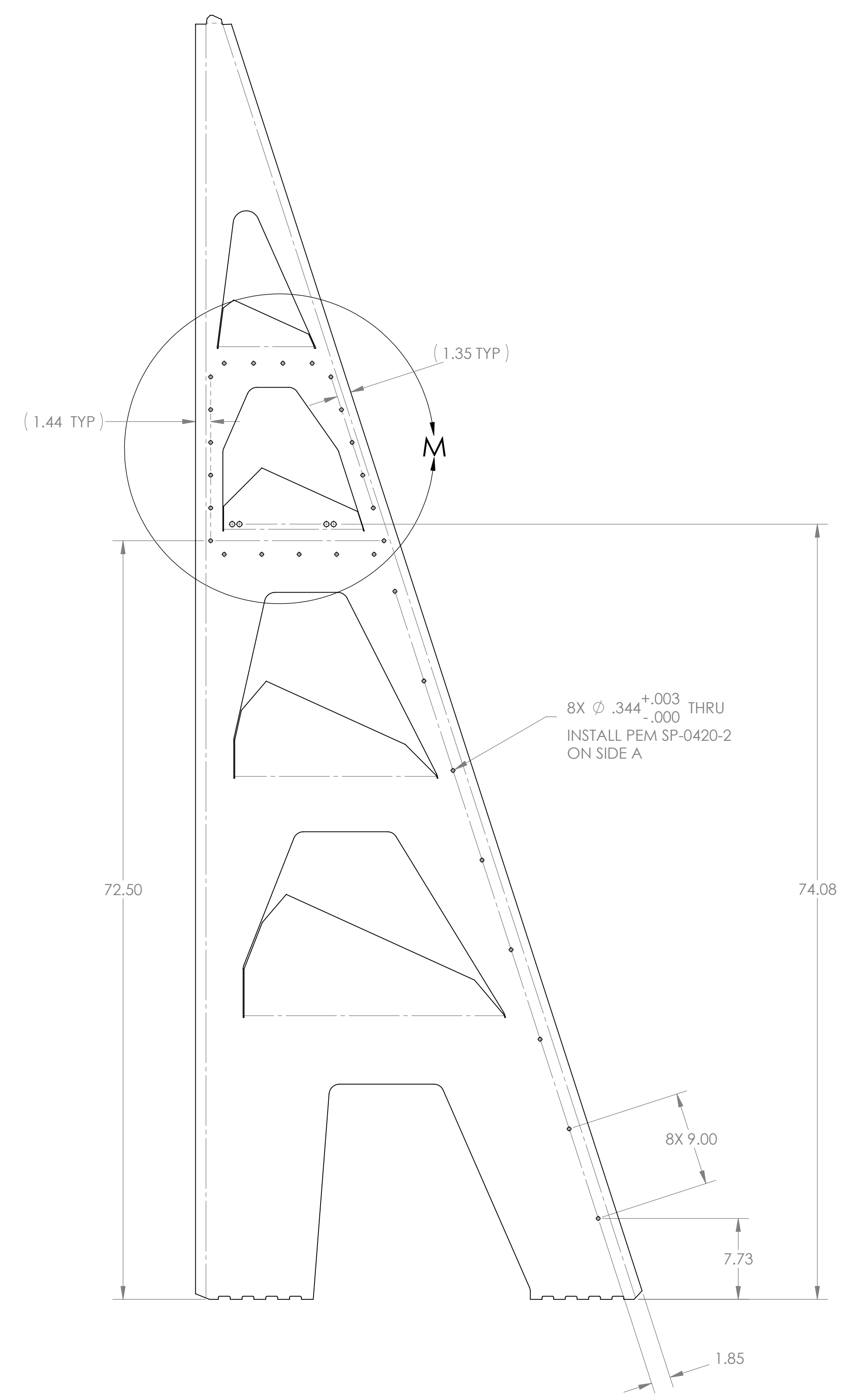

DETAIL M  
SCALE 1 : 4

**LIGO** CALIFORNIA INSTITUTE OF TECHNOLOGY  
 MASSACHUSETTS INSTITUTE OF TECHNOLOGY

SIZE	DWG. NO.	REV.
D	D1000596	v1
SCALE: 1:16	PROJECTION:	SHEET 3 OF 3

8 7 6 5 4 3 2 1

H G F E D C B A

D:\000596\ligo\ACS\Ocler\ & Photo\Cal PX Per Side Pinned (LLO).PART.PDM.REV.X-008.DRAWING.PDM.REV.X-005

**NOTES CONTINUED:**

⑤ SCRIBE, ENGRAVE, OR MECHANICALLY STAMP (NO INKS OR DYES) DRAWING PART NUMBER, REVISION (AND VARIANT OR TYPE IF APPLICABLE) ON NOTED SURFACE OF PART FOLLOWED ON THE NEXT LINE WITH A THREE DIGIT SERIAL NUMBER. SERIAL NUMBERS START AT 001 FOR THE FIRST ARTICLE AND PROCEED CONSECUTIVELY. USE MINIMUM 0.12" HIGH CHARACTERS, UNLESS THE SIZE OF THE PART DICTATES SMALLER CHARACTERS. A VIBRATORY TOOL MAY BE USED. EXAMPLE: DXXXXXX-VY, TYPE-XX, S/N XXX

⑥ FASTEN ITEMS 1 TO D1000836 FOOTING BEFORE APPLYING NOTED WELDS, TO ENSURE ALIGNMENT. FOR EACH ITEM 1, USE THREE 1/2-20 UNF SCREWS TO TAPPED HOLES IN FOOTING. FOOTING MUST BE REMOVABLE & RE-ATTACHABLE POST-WELD, WITH NO BINDING OF SCREWS. TO BE DELIVERED WITH FOOTING ATTACHED.

⑦ WARPAGE OF ITEM 1 & FOOTING TO BE MINIMIZED USING PREFERRED METHODS, I.E. HEAT SINKING.

8. THIS UNIT IS MIRROR IMAGE OPPOSITE OF D1001292. SEE DRAWING D1001292 FOR COMPLETE CONSTRUCTION DETAILS.

REV.	DATE	DCN #	DRAWING TREE #
v1	17 AUGUST 2010	E1000182-v1	-
-	-	-	-
-	-	-	-

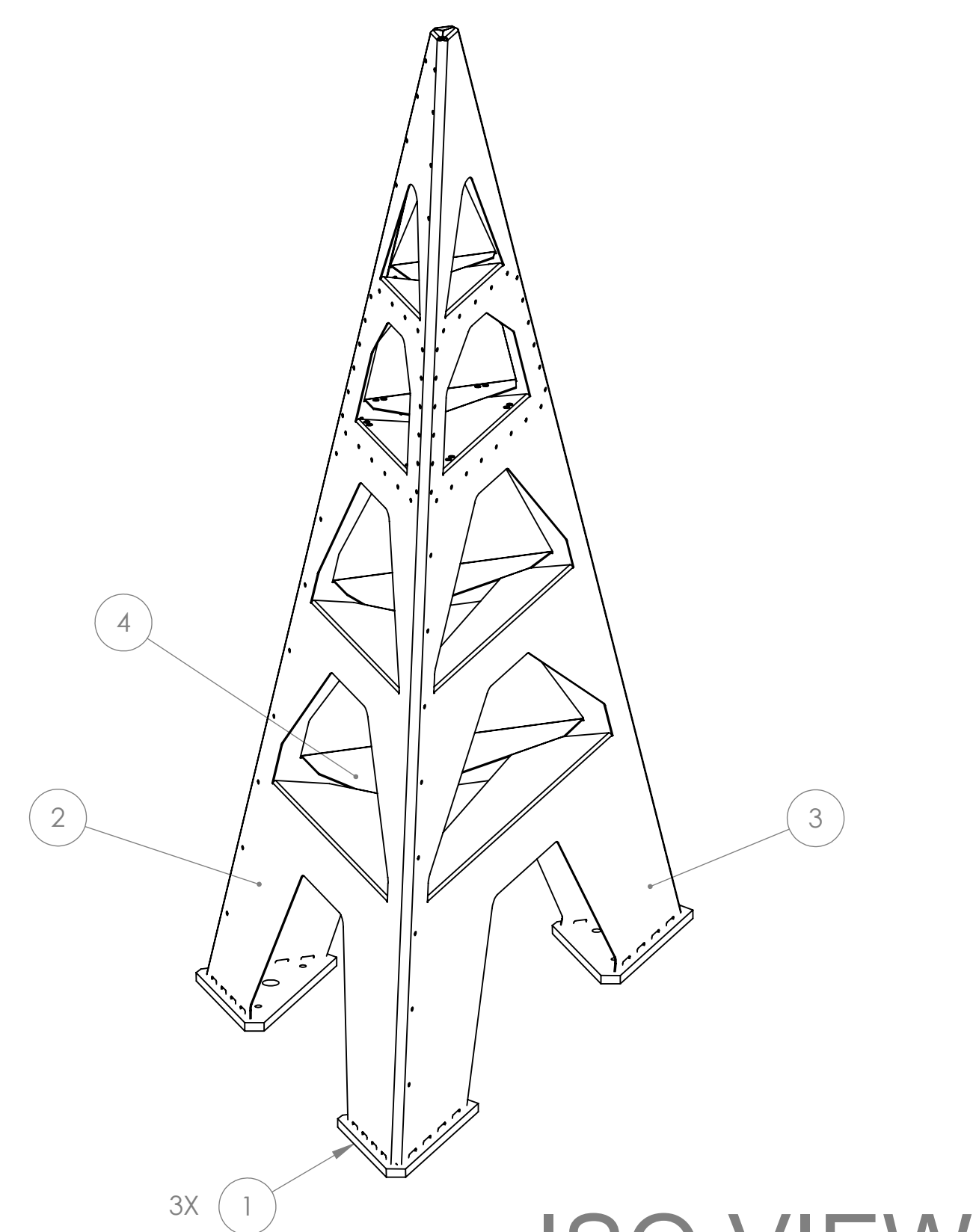
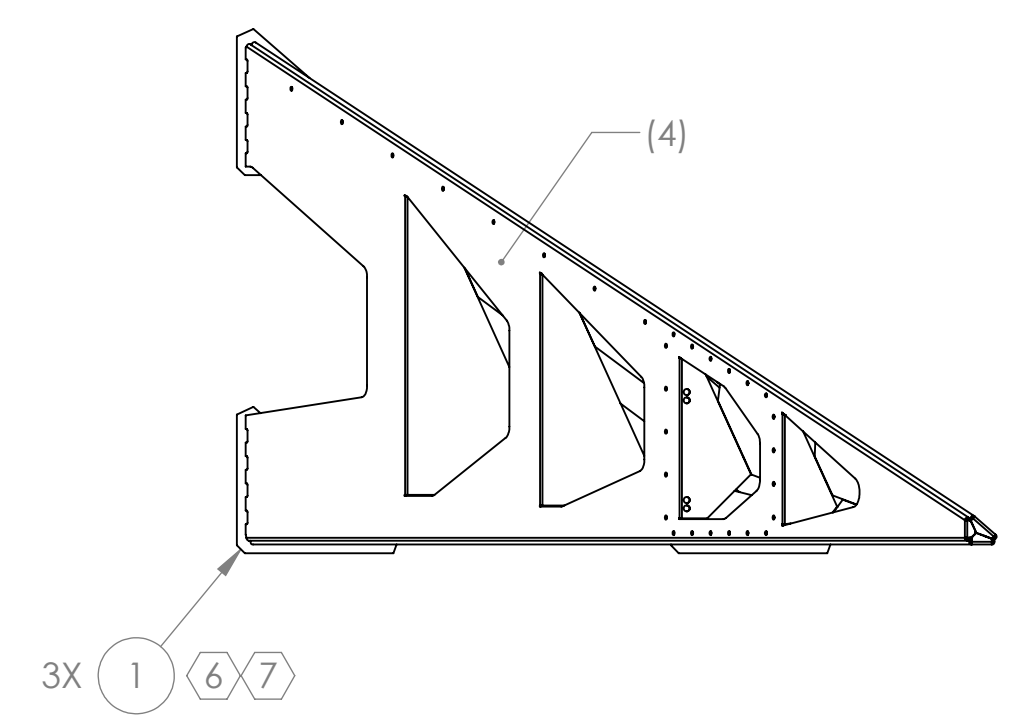

ISO VIEW

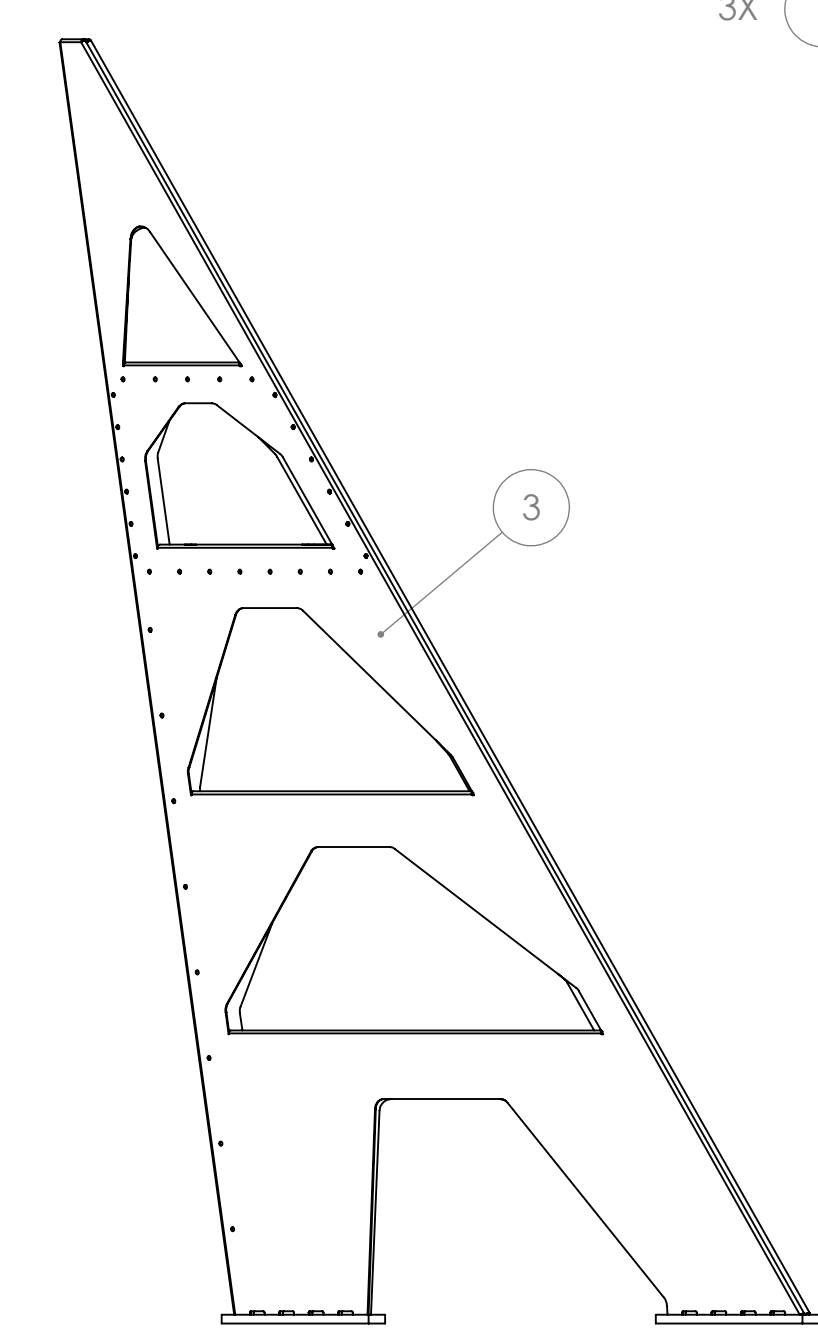
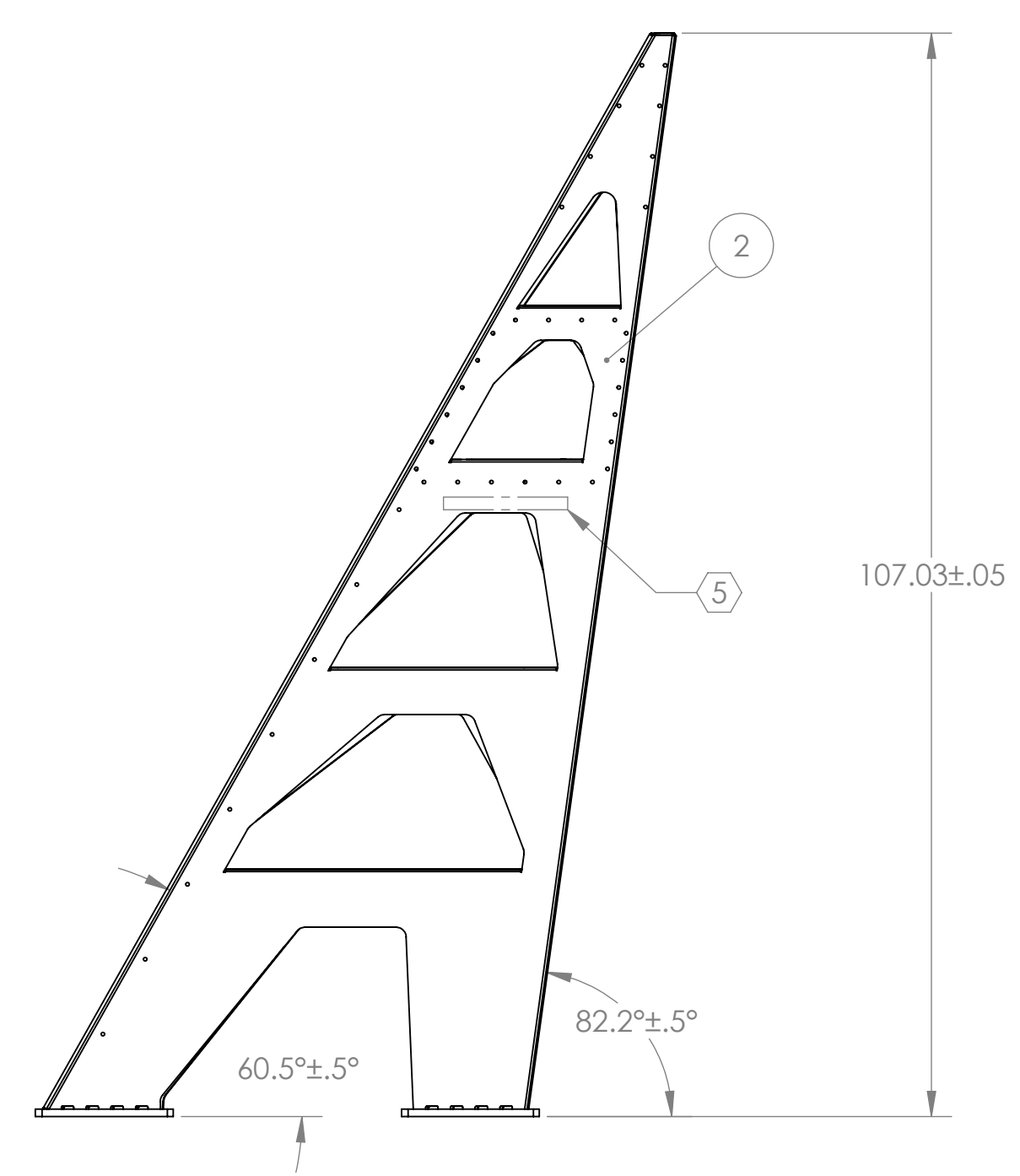
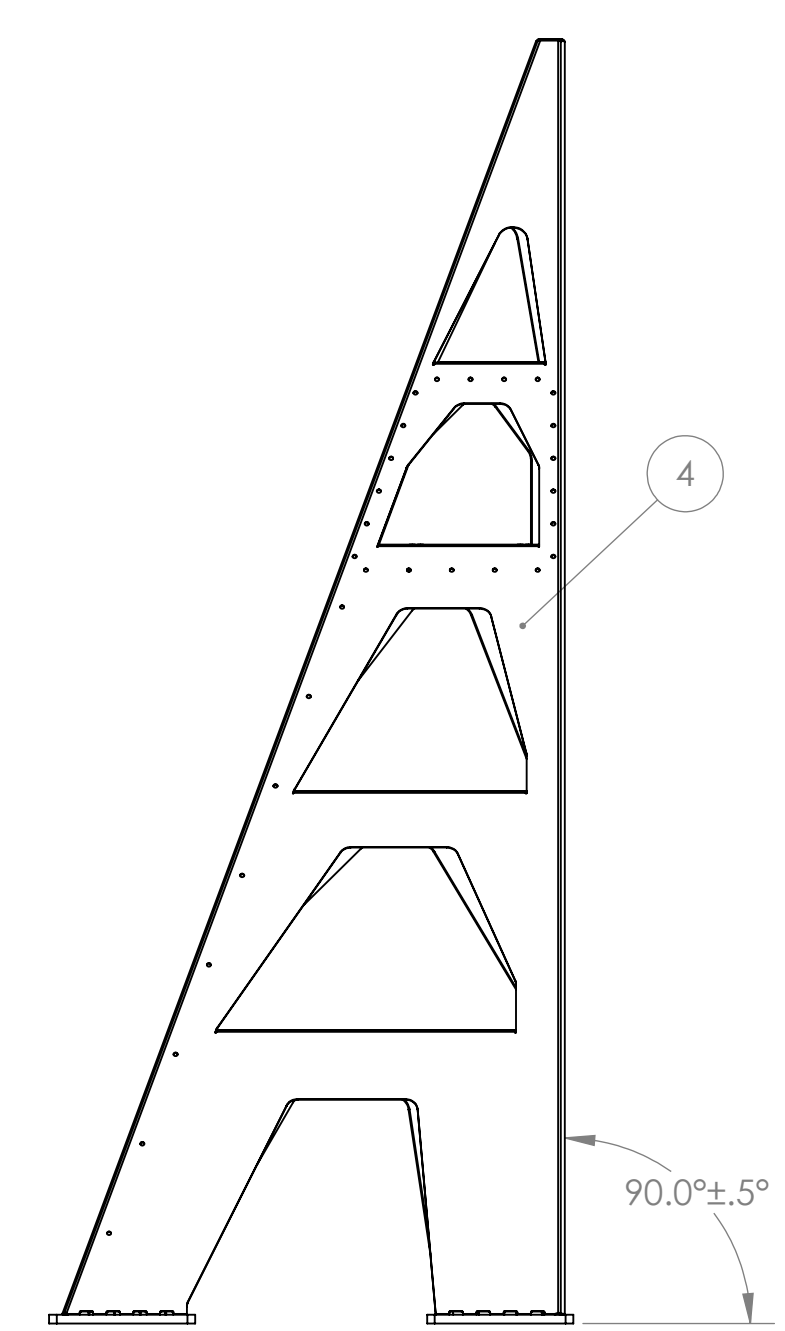
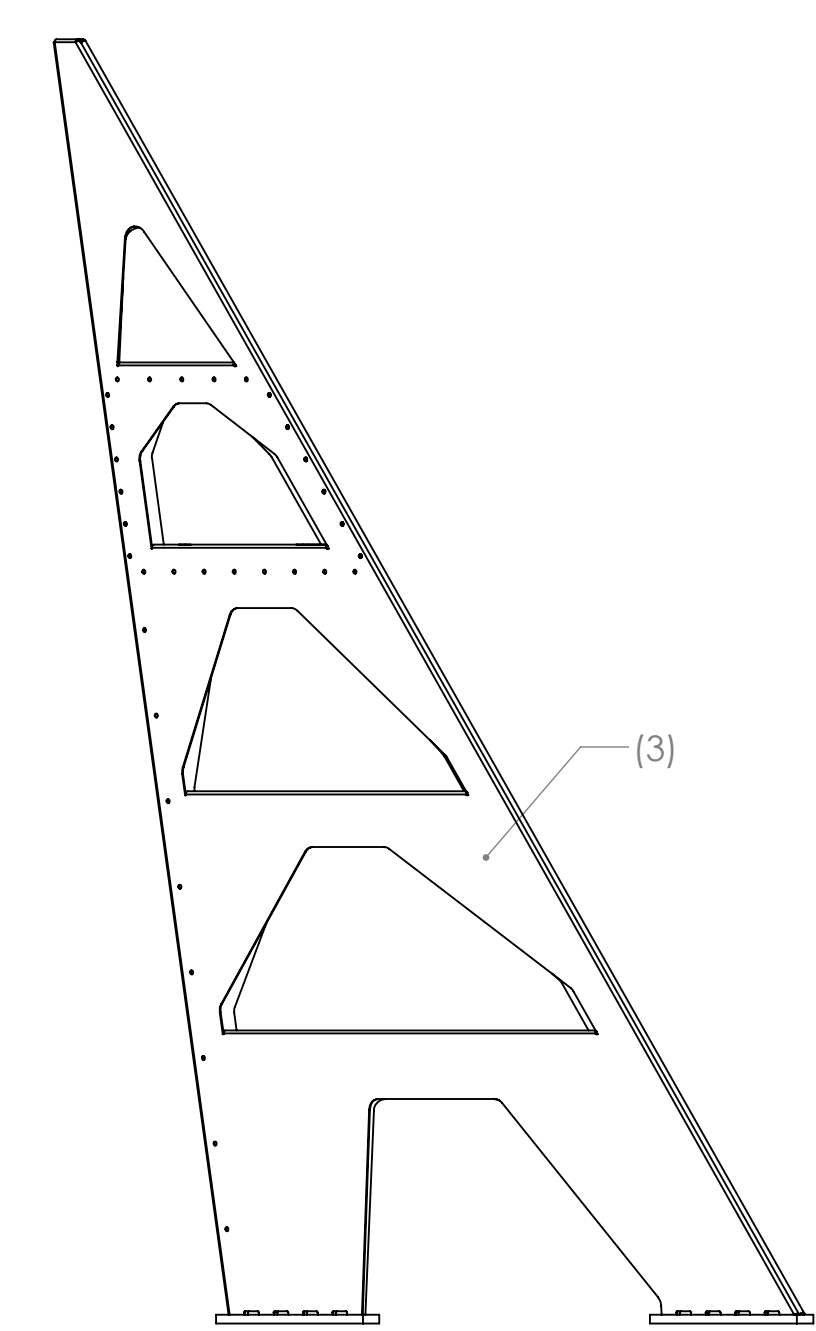

ITEM NO.	PART NUMBER	DESCRIPTION	MATERIAL	REQ	SPARE	TOTAL
4	D1000596-2	ALIGO AOS OPLEV & PHOTCAL RX PIER SIDE PANEL3 (LLO)	304 SSSL	1		1
3	D1000595-2	ALIGO AOS OPLEV & PHOTCAL RX PIER SIDE PANEL2 (LLO)	304 SSSL	1		1
2	D1000594-2	ALIGO AOS OPLEV & PHOTCAL RX PIER SIDE PANEL1 (LLO)	304 SSSL	1		1
1	D1000835	ALIGO AOS PIER BASE 4	304 SSSL	3		3

NOTES AND TOLERANCES: (UNLESS OTHERWISE SPECIFIED)	
1. INTERPRET DRAWING PER ASME Y14.5-1994.	
2. REMOVE ALL SHARP EDGES, R.02 MIN.	
3. DO NOT SCALE FROM DRAWING.	
4. ALL MACHINING FLUIDS MUST BE FULLY SYNTHETIC, FULLY WATER SOLUBLE AND FREE OF SULFUR, SILICONE, AND CHLORINE.	
DIMENSIONS ARE IN	
TOLERANCES:	
.XX ± N/A	
.XXX ± N/A	
ANGULAR ± N/A °	
MATERIAL	N/A
FINISH	N/A μinch

**LIGO** CALIFORNIA INSTITUTE OF TECHNOLOGY  
MASSACHUSETTS INSTITUTE OF TECHNOLOGY

SYSTEM SUB-SYSTEM

NEXT ASSY D1001330

PART NAME ALIGO AOS OPLEV AND PHOTCAL RX PIER WELDMENT RH

DESIGNER	C. CONLEY	17 AUG 2010	SIZE	DWG. NO.	REV.
DRAFTER	N. KILPATRICK	17 AUG 2010	D	D1001297	v1
CHECKER					
APPROVAL			SCALE: 1:16	PROJECTION:	SHEET 1 OF 1

D1001297.dwg: AOS Oplev & Photcal RX Pier Weldment RH (LLO). PAPER: PDM REV: X-019. DRAWING: PDM REV: X-013

- NOTES CONTINUED:**
- ⑤ SCRIBE, ENGRAVE, OR MECHANICALLY STAMP (NO INKS OR DYES) DRAWING PART NUMBER, REVISION (AND VARIANT OR TYPE IF APPLICABLE) ON NOTED SURFACE OF PART FOLLOWED ON THE NEXT LINE WITH A THREE DIGIT SERIAL NUMBER. SERIAL NUMBERS START AT 001 FOR THE FIRST ARTICLE AND PROCEED CONSECUTIVELY. USE MINIMUM 0.12" HIGH CHARACTERS, UNLESS THE SIZE OF THE PART DICTATES SMALLER CHARACTERS. A VIBRATORY TOOL MAY BE USED. EXAMPLE: DXXXXXX-VY, TYPE-XX, S/N XXX
  - ⑥ AFTER COMPLETION OF THE WELDMENT, MACHINE AT TOP OF ITEM 3 TO NOTED SPECIFICATIONS IF NECESSARY. LEVEL THE UPPER FACE OF ITEM 3 (SQUARE WITH MACHINING HEAD) BEFORE MACHINING.
  - ⑦ FASTEN ITEMS 2 TO D1000434 FOOTING BEFORE APPLYING NOTED WELDS, TO ENSURE ALIGNMENT. FOR EACH ITEM 2, USE THREE 1/2-20 UNF SCREWS TO TAPPED HOLES IN FOOTING. FOOTING MUST BE REMOVABLE & RE-ATTACHABLE POST-WELD, WITH NO BINDING OF SCREWS. TO BE DELIVERED WITH FOOTING ATTACHED.
  - ⑧ WARPAGE OF ITEMS 2, 3, & FOOTING TO BE MINIMIZED USING PREFERRED METHODS, IE. HEAT SINKING.

REV.	DATE	DCN #	DRAWING TREE #
v1	09 AUGUST 2010	E1000182-v1	-
-	-	-	-
-	-	-	-

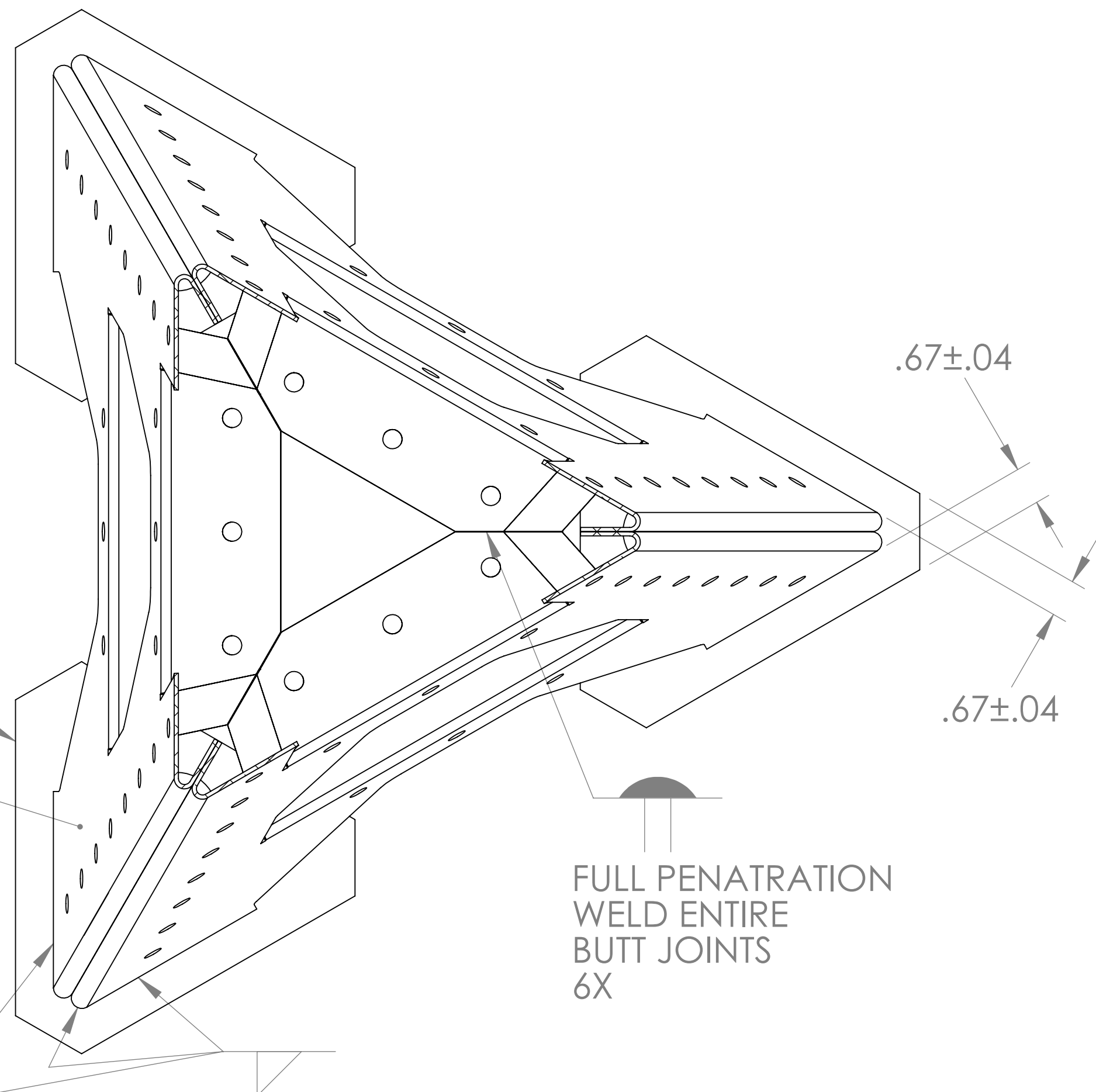

FILLET WELD ALL ITEM 1 / ITEM 2 INTERFACES (OUTSIDE ONLY) ALL THREE LOCATIONS

⑦ ⑧ SECTION A-A

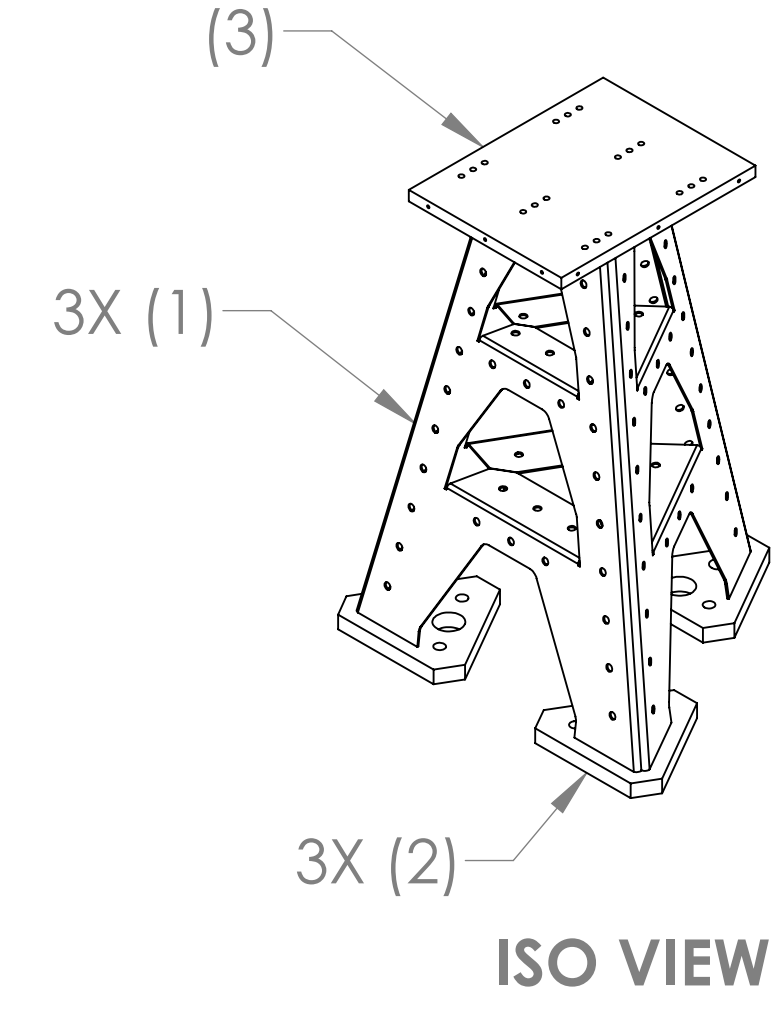
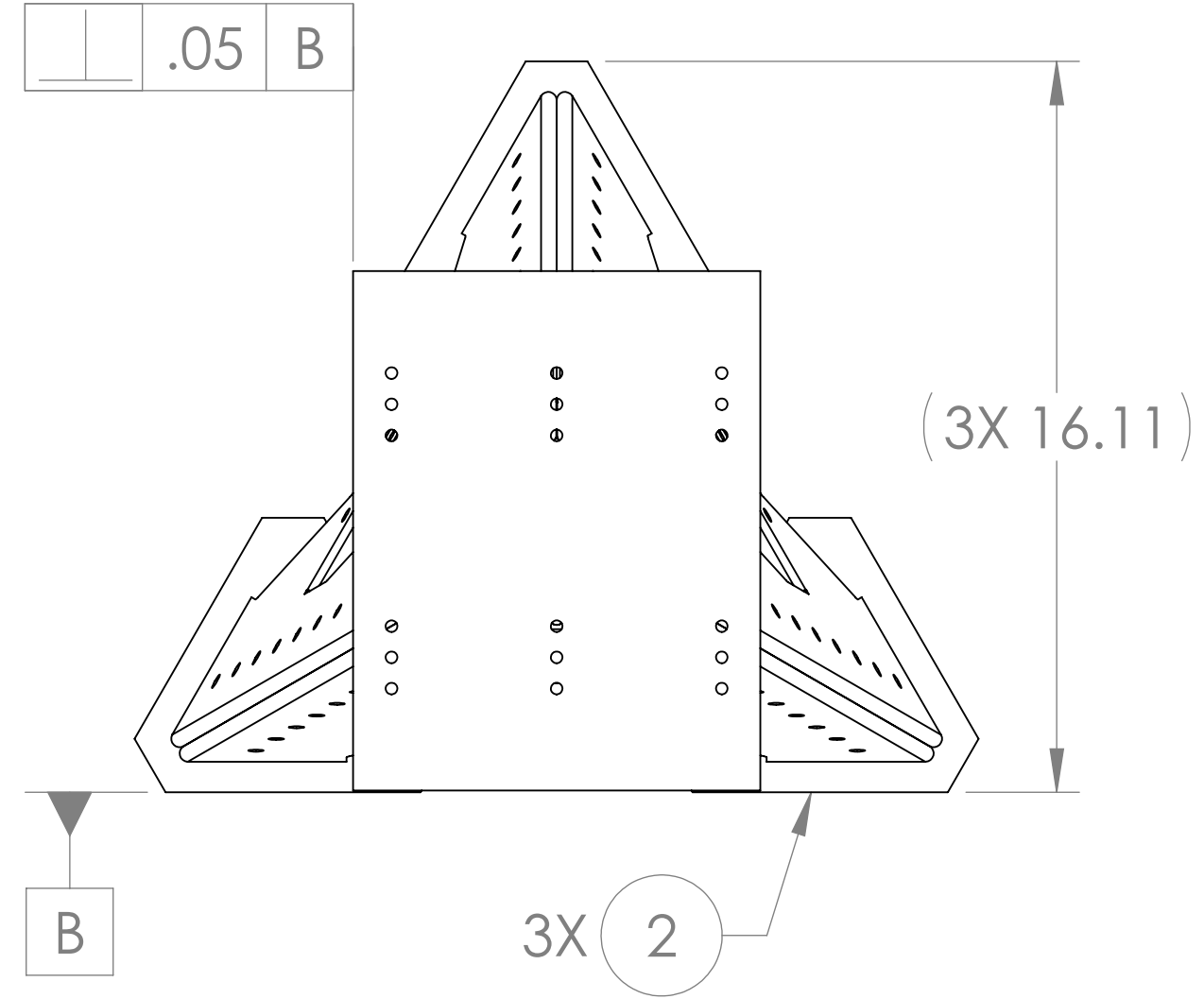

ISO VIEW

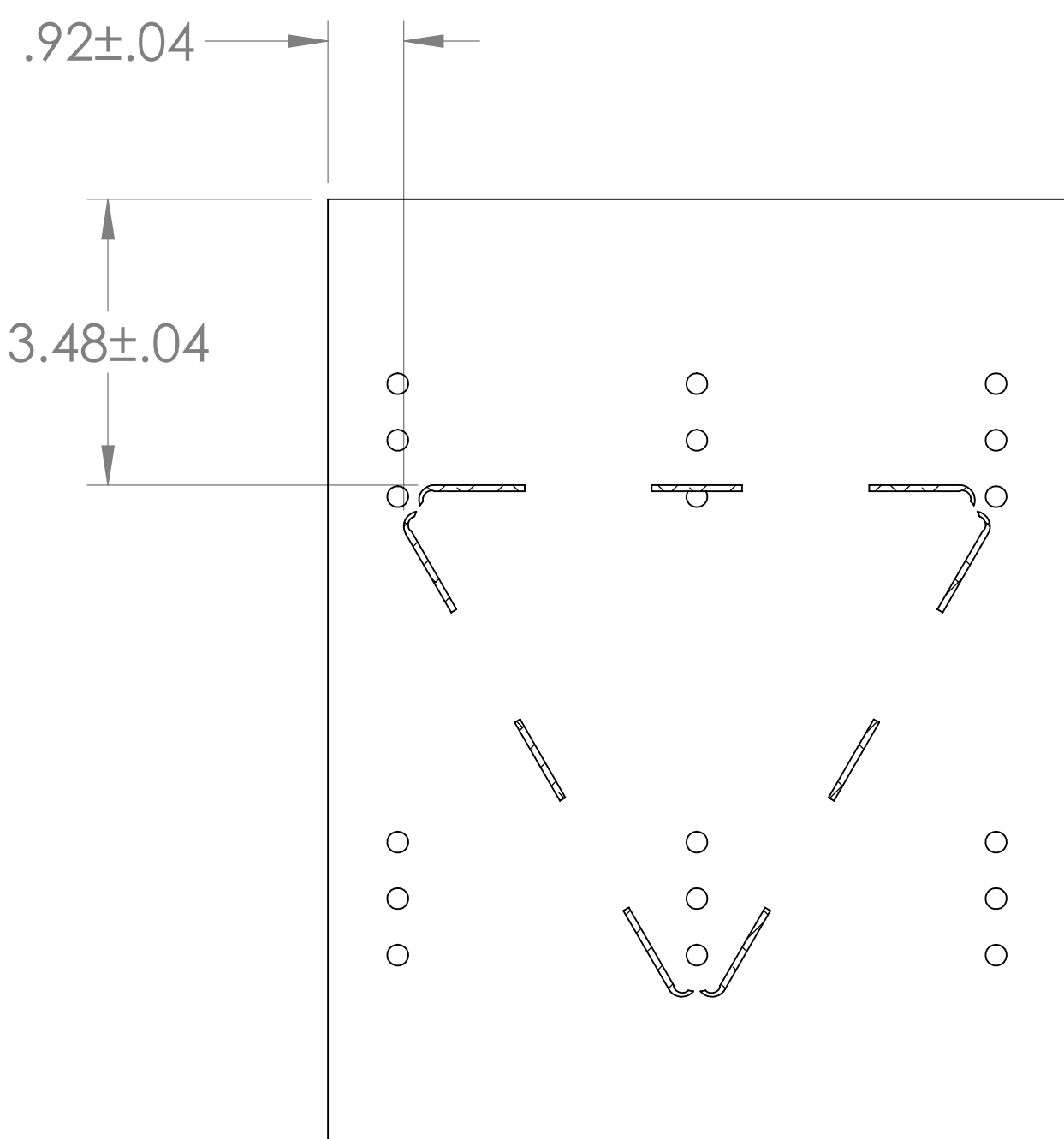

SECTION B-B  
SCALE 1 : 2

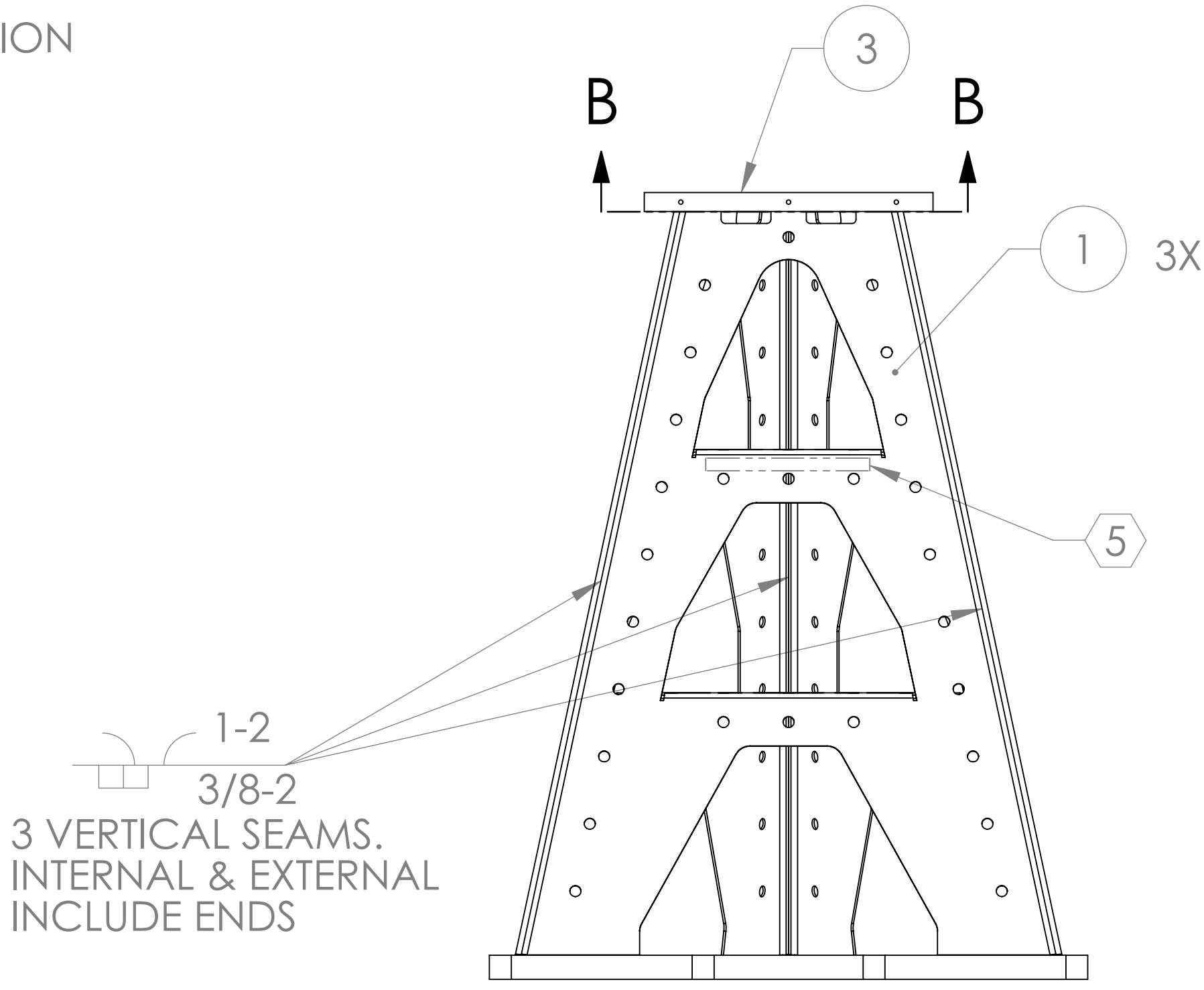

1-2  
3/8-2  
3 VERTICAL SEAMS. INTERNAL & EXTERNAL INCLUDE ENDS

FILLET WELD ALL ITEM 1 / ITEM 3 INTERFACES (OUTSIDE ONLY) ALL THREE LOCATIONS

⑧

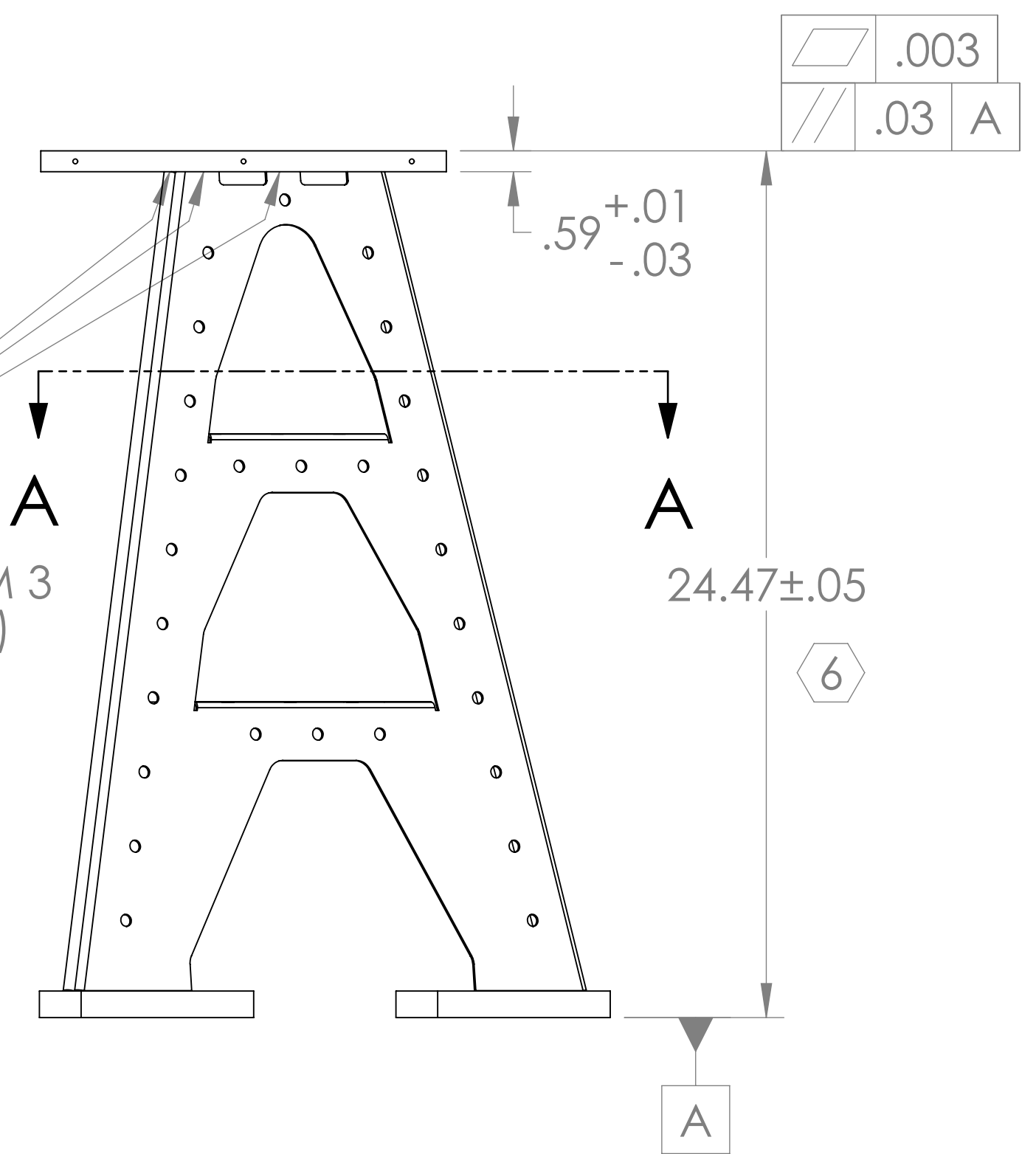

.003  
.03 A

24.47±.05  
⑥

NOTES AND TOLERANCES: (UNLESS OTHERWISE SPECIFIED)	
1. INTERPRET DRAWING PER ASME Y14.5-1994.	
2. REMOVE ALL SHARP EDGES, R.02 MIN.	
3. DO NOT SCALE FROM DRAWING.	
4. ALL MACHINING FLUIDS MUST BE FULLY SYNTHETIC, FULLY WATER SOLUBLE AND FREE OF SULFUR, SILICONE, AND CHLORINE.	
DIMENSIONS ARE IN INCHES	
TOLERANCES:	
.XX ± N/A	
.XXX ± N/A	
ANGULAR ± N/A°	
MATERIAL	N/A
FINISH	N/A μinch

CALIFORNIA INSTITUTE OF TECHNOLOGY MASSACHUSETTS INSTITUTE OF TECHNOLOGY	
SYSTEM	ADVANCED LIGO
SUB-SYSTEM	AOS
NEXT ASSY	D1001334

ITEM NO.	PART NUMBER	DESCRIPTION	MATERIAL	REQ	SPARE	TOTAL
3	D1001611-2	ALIGO AOS OPLEV TRX PIER TABLE (HAM)	304 SSSL	1		1
2	D1000426	ALIGO AOS PIER BASE 1	304 SSSL	3		3
1	D1001857	ALIGO AOS OPLEV TX PIER SIDE PANEL (PR3, SR3)	304 SSSL	3		3

PART NAME		ALIGO AOS	
Oplev Tx Pier Weldment (PR3, SR3)		Oplev Tx Pier Weldment (PR3, SR3)	
DESIGNER	C. CONLEY	DATE	6 AUG 2010
DRAFTER	N. KILPATRICK	DATE	09 AUG 2010
CHECKER		SIZE	D
APPROVAL		DWG. NO.	D1001301
		REV.	v1
		SCALE:	1:4
		PROJECTION:	
		SHEET 1 OF 1	

D1001301.dwg Oplev Tx Pier Weldment (PR3, SR3).PART PDM REV: X-012. DRAWING PDM REV: X-002

NOTES CONTINUED:  
 (1) STOCK FINISH / AS RECEIVED.

REV.	DATE	DCN #	DRAWING TREE #
v1	08 AUGUST 2010	E1000182-v1	-
-	-	-	-
-	-	-	-

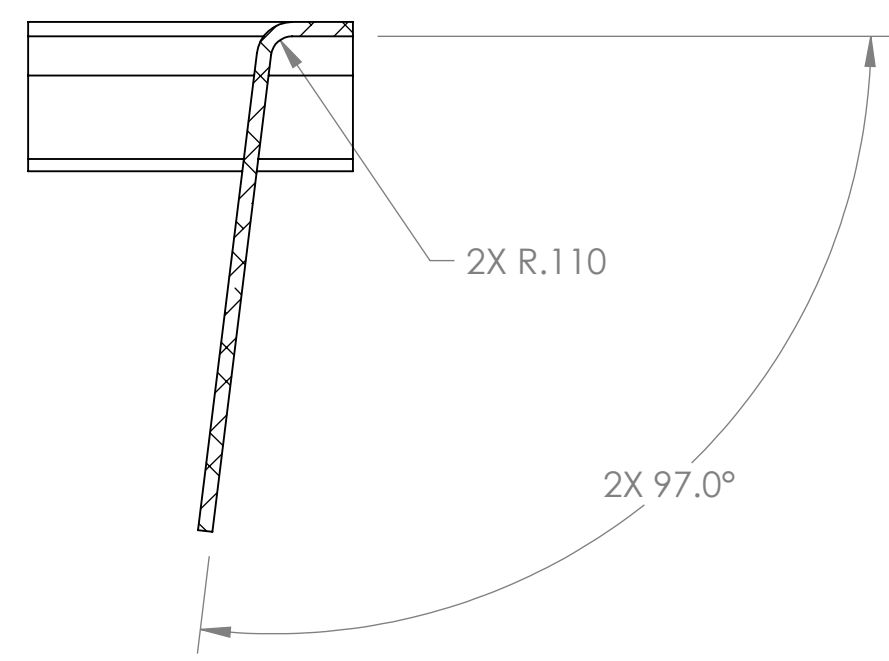

SECTION A-A  
SCALE 1 : 1

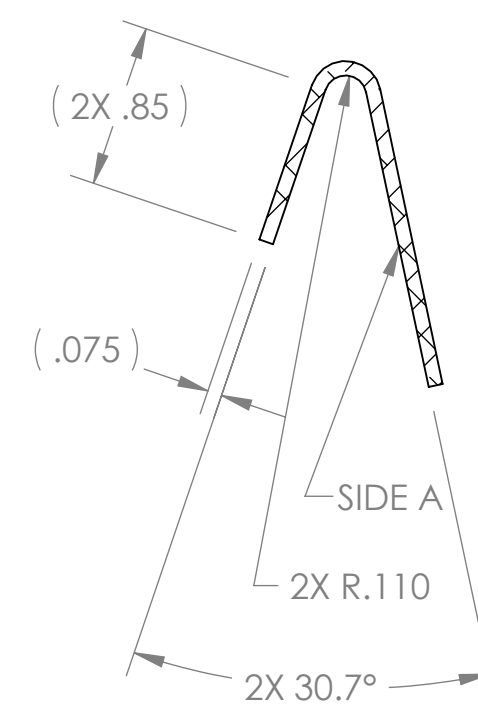

SECTION B-B  
SCALE 1 : 1

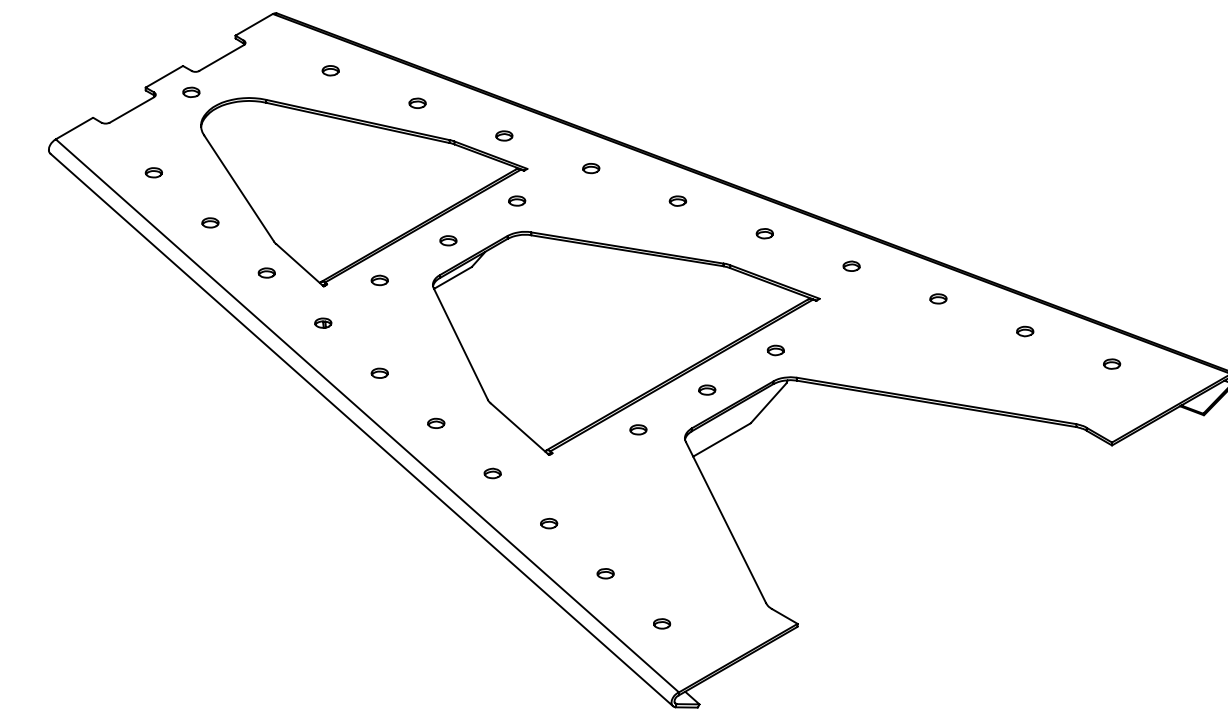

ISO VIEW

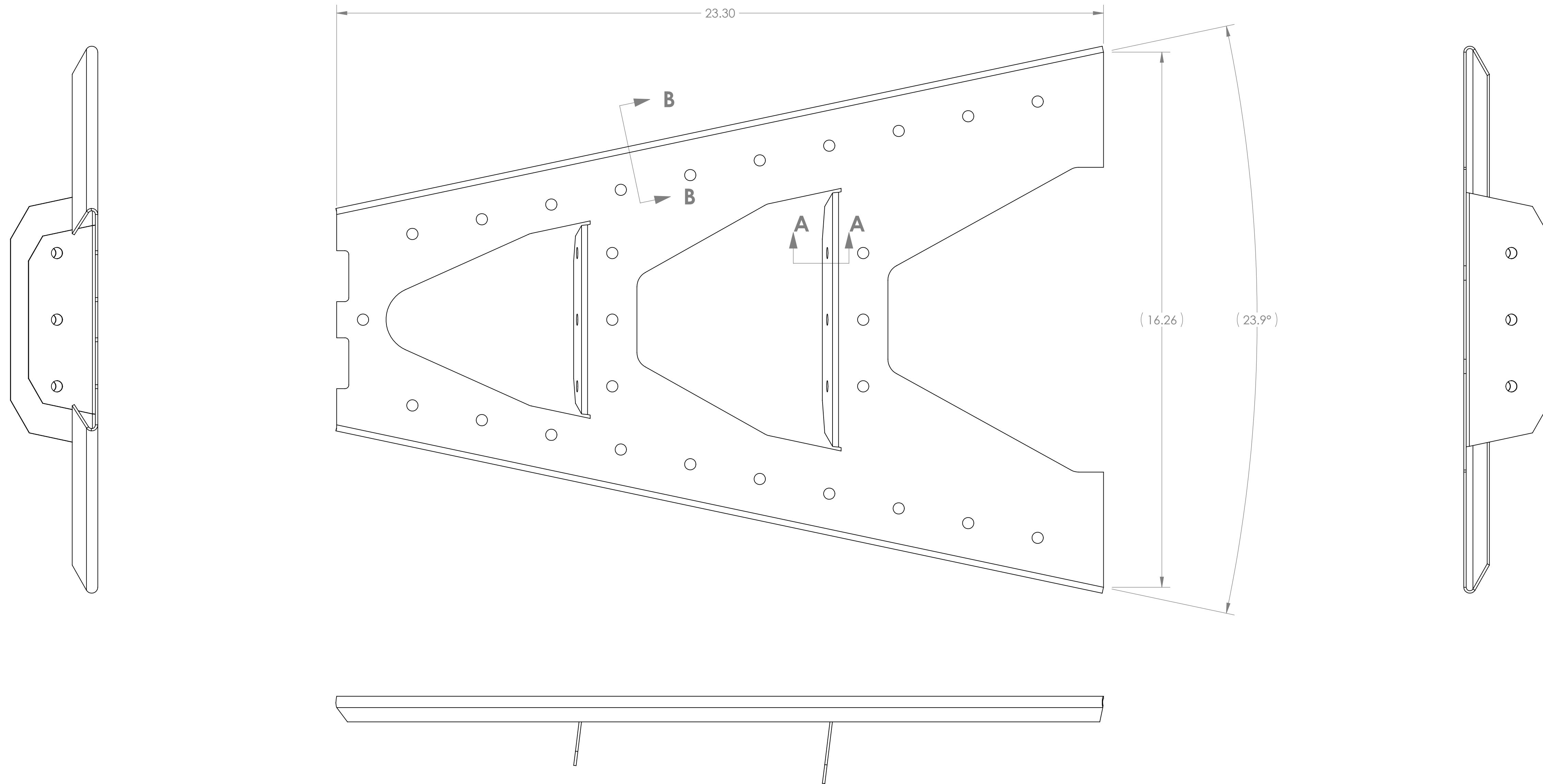

NOTES AND TOLERANCES: (UNLESS OTHERWISE SPECIFIED)	
1. INTERPRET DRAWING PER ASME Y14.5-1994. 2. REMOVE ALL SHARP EDGES, R.02 MIN. 3. DO NOT SCALE FROM DRAWING. 4. ALL MACHINING FLUIDS MUST BE FULLY SYNTHETIC, FULLY WATER SOLUBLE AND FREE OF SULFUR, SILICONE, AND CHLORINE.	
DIMENSIONS ARE IN INCHES TOLERANCES: .XX ± .01 .XXX ± .005 ANGULAR ± 1.0°	MATERIAL <b>304 SSSL SHEET, 14 GAUGE</b>
FINISH (1)	NEXT ASSY <b>D1001301</b>

CALIFORNIA INSTITUTE OF TECHNOLOGY MASSACHUSETTS INSTITUTE OF TECHNOLOGY	
SYSTEM <b>ADVANCED LIGO</b>	SUB-SYSTEM <b>AOS</b>
NEXT ASSY <b>D1001301</b>	

PART NAME <b>ALIGO AOS            OPLEV TX PIER SIDE PANEL (PR3, SR3)</b>			
DESIGNER C. CONLEY	DATE 6 AUG 2009	SIZE <b>D</b>	DWG. NO. <b>D1001857</b>
DRAFTER N. KILPATRICK	DATE 09 AUG 2010	REV. <b>v1</b>	SCALE: 1:2
CHECKER	APPROVAL	PROJECTION:	SHEET 1 OF 2

D:\001857\aligo AOS\Oplev TX Pier Side Panel (PR3, SR3).J PART PDM REV: X-000. DRAWING PDM REV: X-004

8 7 6 5 4 3 2 1

H G F E D C B A

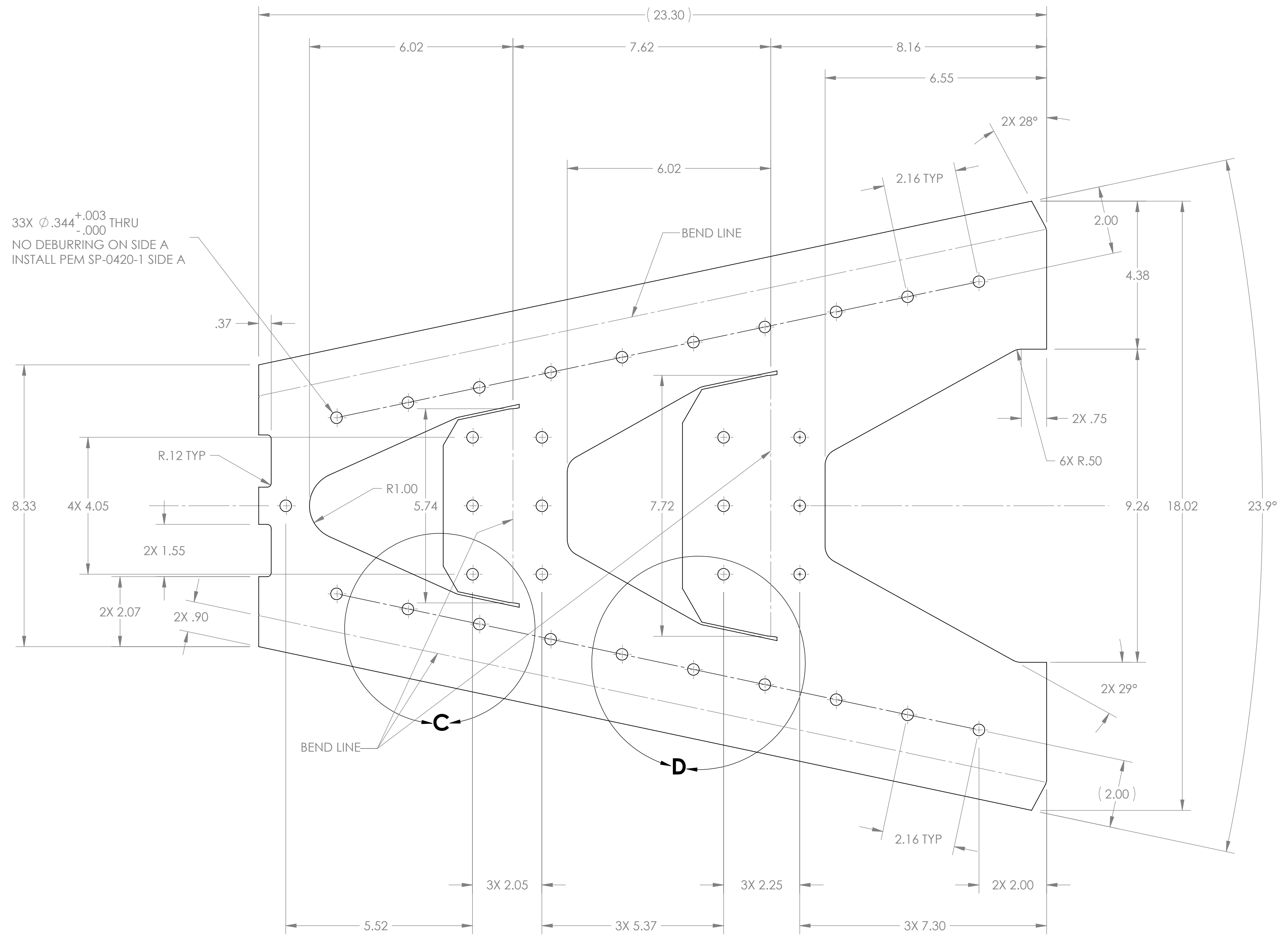
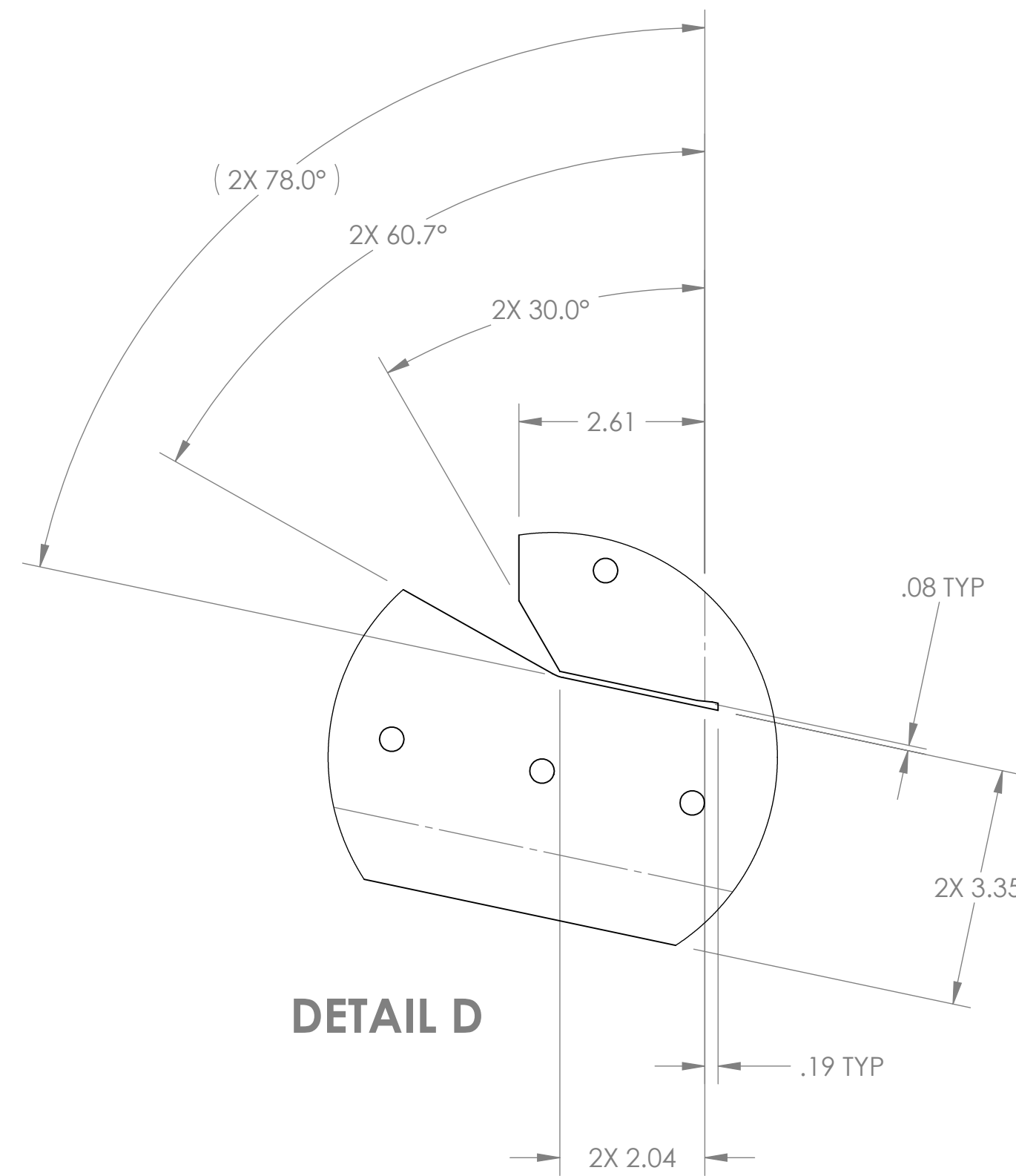
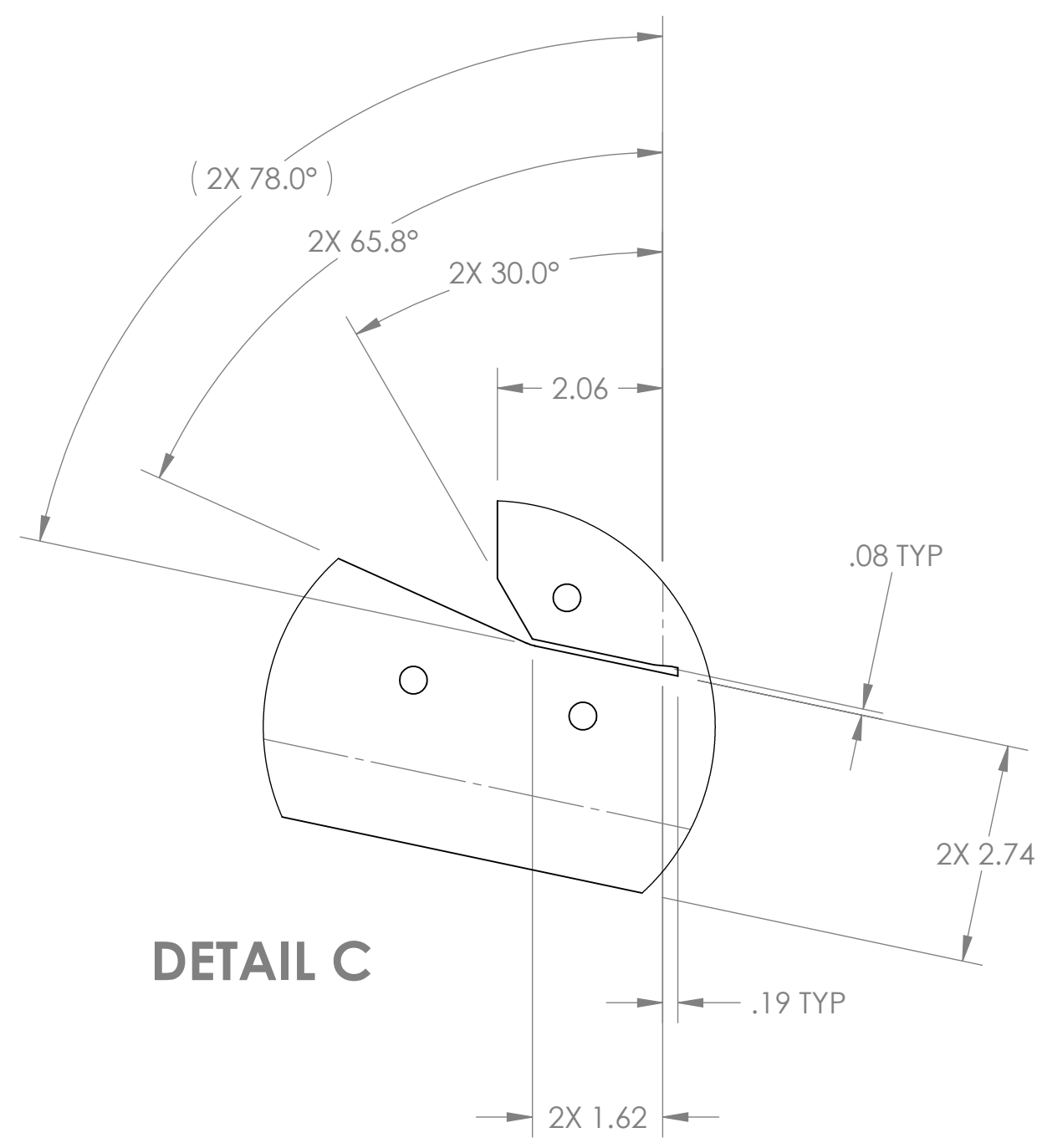

33X  $\varnothing .344^{+.003}_{-.000}$  THRU  
 NO DEBURRING ON SIDE A  
 INSTALL PEM SP-0420-1 SIDE A

<b>LIGO</b> CALIFORNIA INSTITUTE OF TECHNOLOGY MASSACHUSETTS INSTITUTE OF TECHNOLOGY	
SIZE DWG. NO.	REV.
<b>D</b> <b>D1001857</b>	<b>v1</b>
SCALE: 1:2	PROJECTION:
SHEET 2 OF 2	

D:\001857.dwg ACS C:\dev\TX File Side Panel (PES, S3) \PART PDM REV\X-200\_DRAWING PDM REV\_X-004

D1001611 aLIGO AOS OpLev Pier Table (HAM, PR3, SR3), PART PDM REV: X-032, DRAWING PDM REV: X-007

**NOTES CONTINUED:**  
 5. SCRIBE, ENGRAVE, OR MECHANICALLY STAMP (NO INKS OR DYES) DRAWING PART NUMBER, REVISION (AND VARIANT OR "TYPE" IF APPLICABLE) ON NOTED SURFACE OF PART FOLLOWED ON THE NEXT LINE WITH A THREE DIGIT SERIAL NUMBER. SERIAL NUMBERS START AT 001 FOR THE FIRST ARTICLE AND PROCEED CONSECUTIVELY. USE MINIMUM 0.12" HIGH CHARACTERS, UNLESS THE SIZE OF THE PART DICTATES SMALLER CHARACTERS. A VIBRATORY TOOL MAY BE USED.  
 EXAMPLE: DXXXXXX-VY, TYPE-XX, S/N XXX

REV.	DATE	DCN #	DRAWING TREE #
v1	18 AUG 2010	E1000182-v1	-
-	-	-	-
-	-	-	-

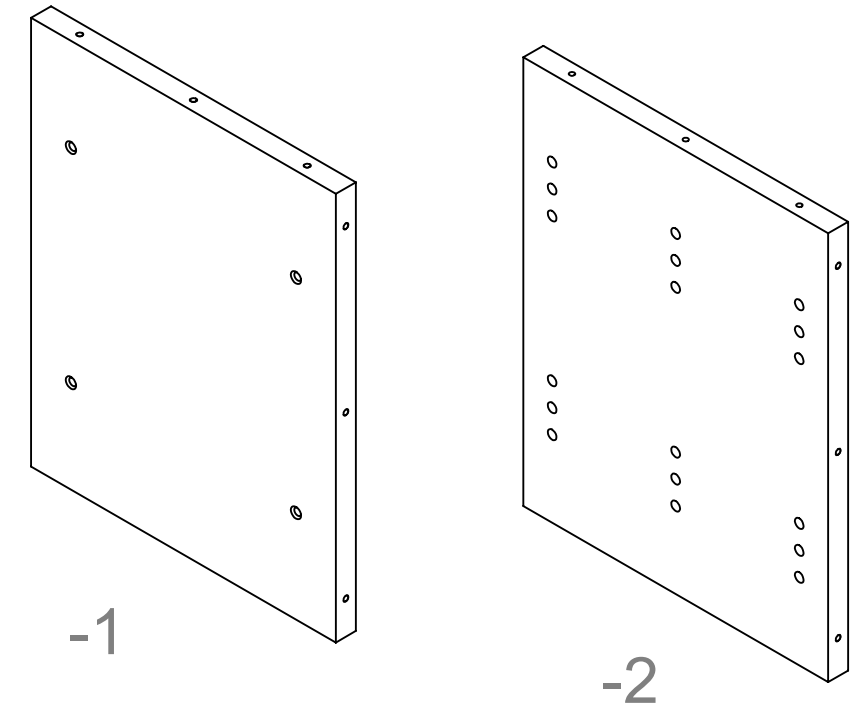
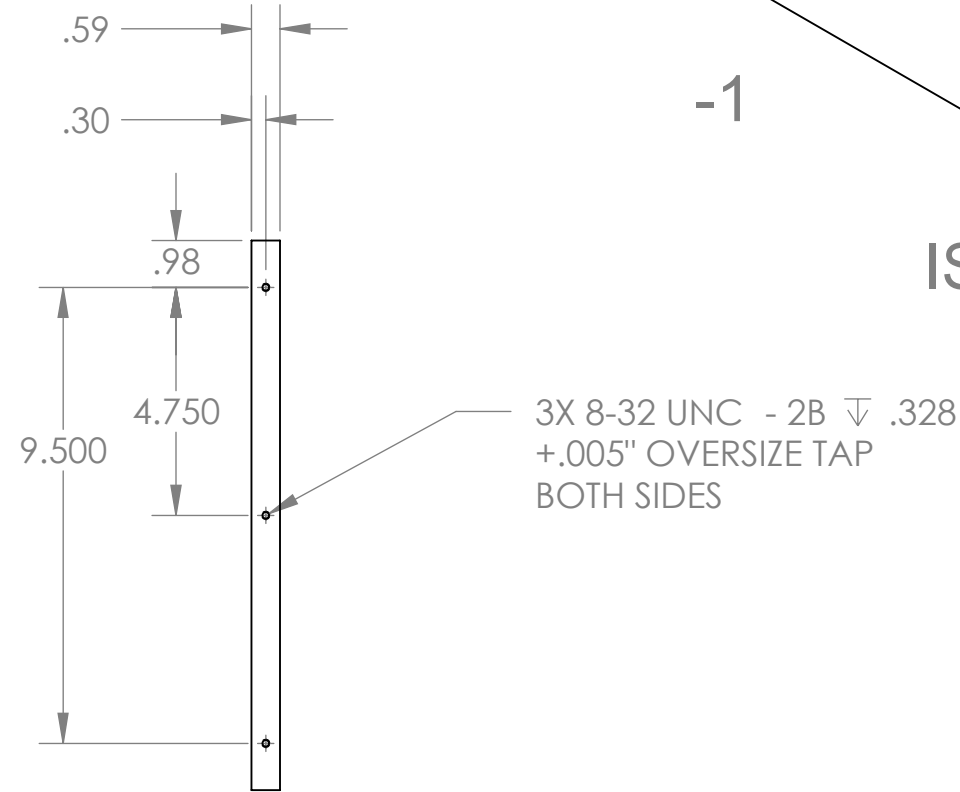
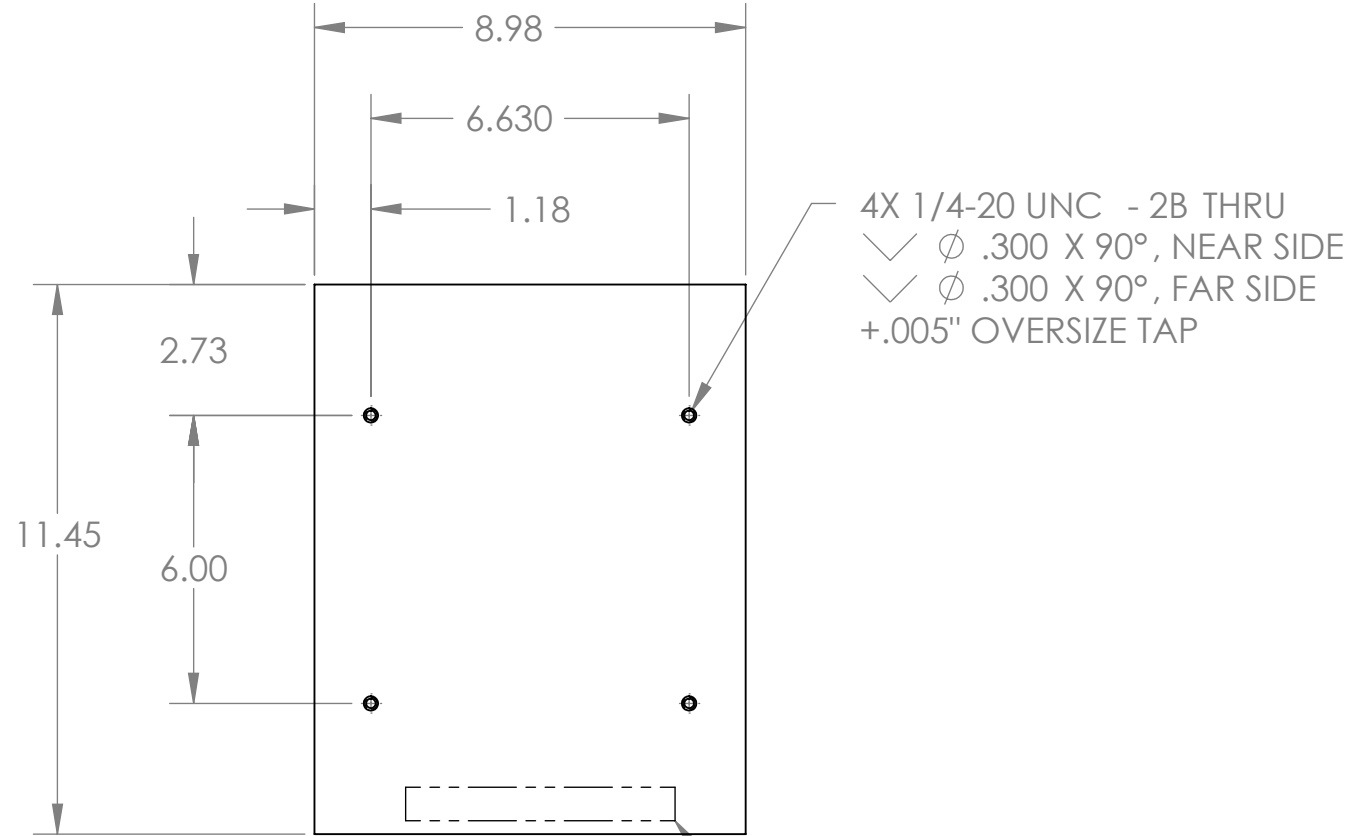
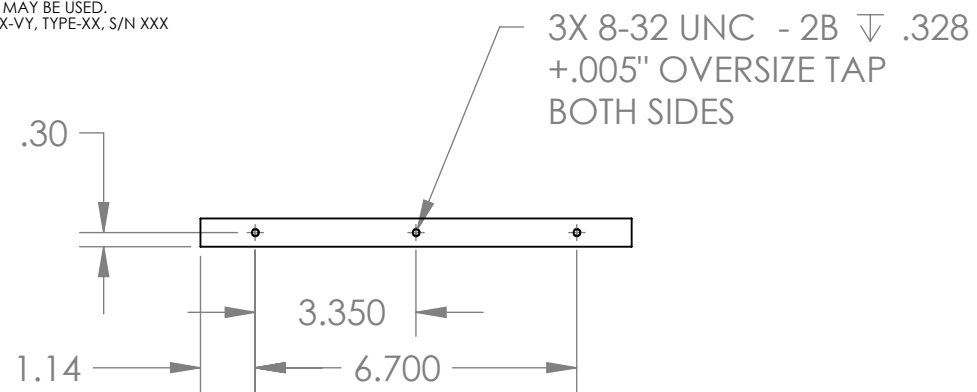

ISO VIEW

5

-1

- 8. MACHINE ALL SURFACES TO REMOVE OXIDES AND MILL FINISH, USE OF ABRASIVE TECHNIQUES IS NOT ALLOWED.
- 7. DO NOT USE SANDPAPER, SCOTCH BRITE OR SIMILAR PRODUCTS.
- 6. ALL PARTS SHALL BE MANUFACTURED IN ACCORDANCE WITH LIGO SPECIFICATION E0900364.

NOTES AND TOLERANCES: (UNLESS OTHERWISE SPECIFIED)	
DIMENSIONS ARE IN INCHES	
TOLERANCES: .XX ± .01 .XXX ± .005	
ANGULAR ± 1.0°	
1. INTERPRET DRAWING PER ASME Y14.5-1994. 2. REMOVE ALL SHARP EDGES, R.02 MIN. 3. DO NOT SCALE FROM DRAWING. 4. ALL MACHINING FLUIDS MUST BE FULLY SYNTHETIC, FULLY WATER SOLUBLE AND FREE OF SULFUR, SILICONE, AND CHLORINE.	
MATERIAL	FINISH
304 SSSL	N/A μinch

CALIFORNIA INSTITUTE OF TECHNOLOGY MASSACHUSETTS INSTITUTE OF TECHNOLOGY		PART NAME	
SYSTEM <b>ADVANCED LIGO</b>		SUB-SYSTEM <b>AOS</b>	
DESIGNER	C. CONLEY	07 MAY 2009	SIZE DWG. NO.
DRAFTER	N. KILPATRICK	18 AUG 2010	<b>B</b>
CHECKER			
APPROVAL			
NEXT ASSY		D1000447, D1000448, D1001301, D1001854	
SCALE: 1:4 PROJECTION:		SHEET 1 OF 2	

ALIGO AOS  
 OPLEV TRX PIER TABLE (HAM)

D1001611

v1

D1001611 dLIGO AOS Oplev Pier Table (HAM, PR3, SR3), PART PDM REV: X-032, DRAWING PDM REV: X-007

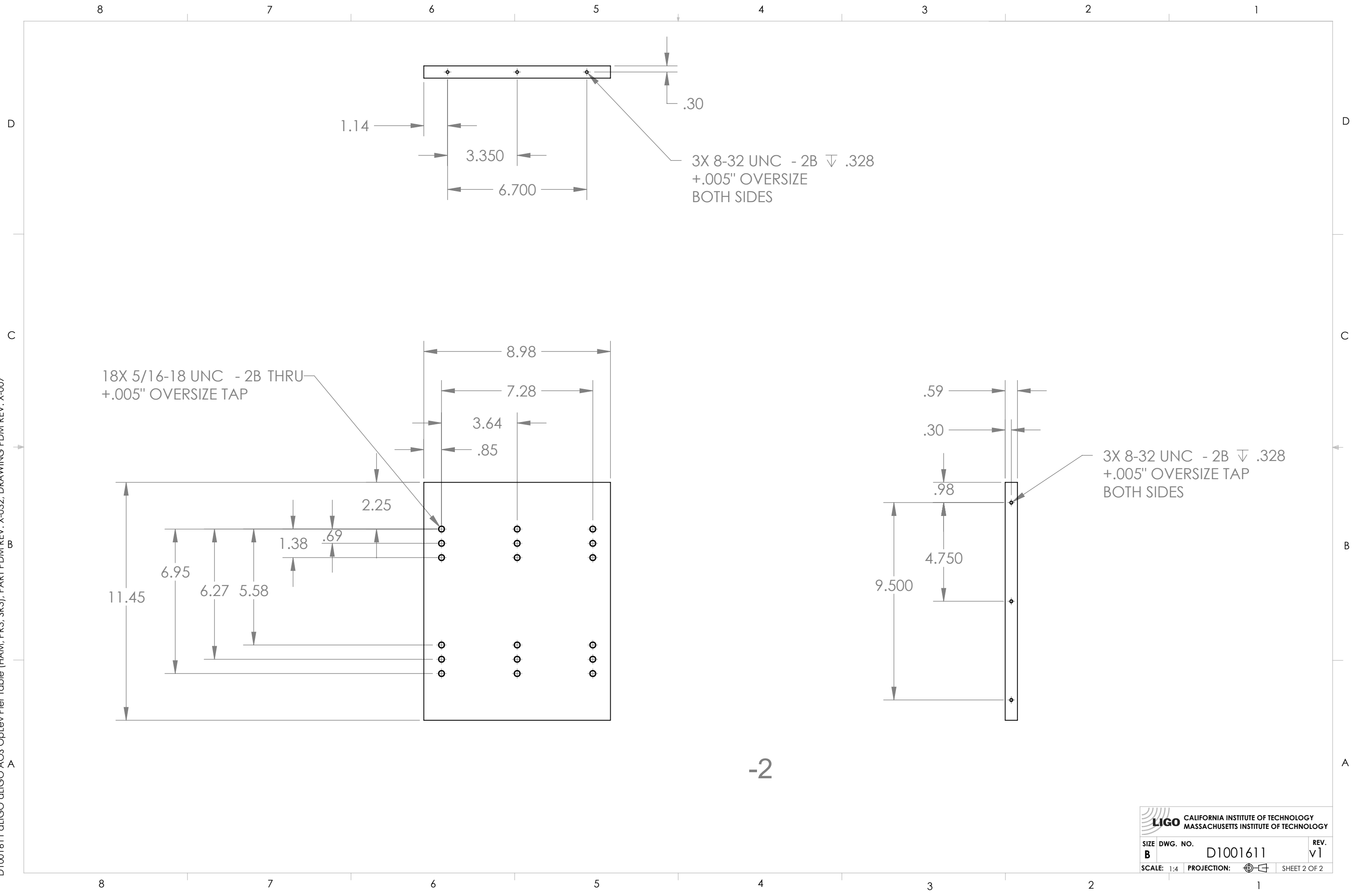

1.14

3.350

6.700

.30

3X 8-32 UNC - 2B  $\nabla$  .328  
+.005" OVERSIZE  
BOTH SIDES

18X 5/16-18 UNC - 2B THRU  
+.005" OVERSIZE TAP

8.98

7.28

3.64

.85

2.25

6.95

6.27

5.58

1.38

.69

11.45

.59

.30

.98

4.750

9.500

3X 8-32 UNC - 2B  $\nabla$  .328  
+.005" OVERSIZE TAP  
BOTH SIDES

-2

**LIGO** CALIFORNIA INSTITUTE OF TECHNOLOGY  
MASSACHUSETTS INSTITUTE OF TECHNOLOGY

SIZE	DWG. NO.	REV.
B	D1001611	v1
SCALE: 1:4	PROJECTION:	SHEET 2 OF 2



**NOTES CONTINUED:**

1. STRUCTURE SHOWN & DIMENSIONED WITH SHARP ADJOINING PANEL CORNERS. ACTUAL PANELS TO BE BENT SIMILARLY TO D1001292 PANELS AT ADJOINING CORNERS. DIMENSIONS TO SAID SHARP CORNERS ARE FOR ESTABLISHING STRUCTURAL SIZE & SHAPE ONLY.
2. ALL BEND RADII .125.
- ③ BASES TO BE FASTENED TO FOOTING DURING WELDING OF BASES TO PANELS. FASTEN EACH BASE USING THREE 1/2-20 UNF SCREWS TO TAPPED HOLES IN FOOTING. FOOTING MUST BE REMOVABLE & RE-ATTACHABLE. POST-WELD, WITH NO BINDING OF SCREWS. WELDMENT TO BE DELIVERED WITH FOOTING ATTACHED.
- ④ WARPAGE OF BASES & FOOTING TO BE MINIMIZED USING PREFERRED METHODS, IE. SCALOPS(STITCH WELDING (50%)), HEAT SINKING.
- ⑤ NOTED DIMENSIONS REPRESENT THE THEORETICAL SHARP CORNER OF TAB FOLD.
- ⑥ FOLDED TABS ARE IDENTICAL EXCEPT FOR NOTED DIMENSIONS.
- ⑦ THEORETICAL SHARP CORNER LINE (BEND LINES TO BE DETERMINED FROM).
- ⑧ ALL PEM NUTS TO BE MOUNTED ON INSIDE OF WELDMENT.

REV.	DATE	DCN #	DRAWING TREE #
v1	18 AUG 2010	E1000182-v1	-
v2	2 DEC 2010	E1000182-v2	-
-	-	-	-

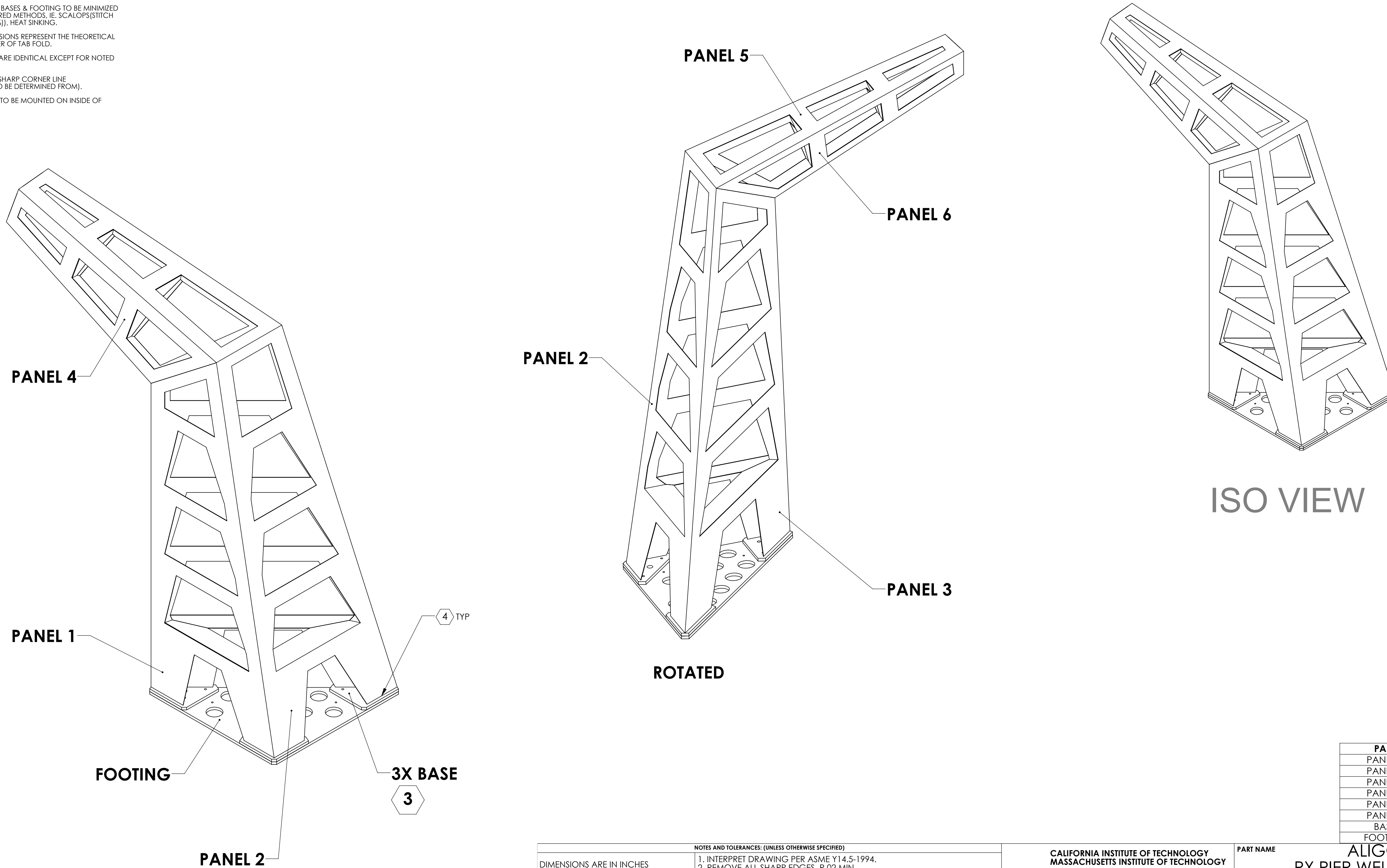

ISO VIEW

ROTATED

PART	MATERIAL	FINISH
PANEL 1	304 SST SHEET, 12 GAUGE	STOCK FINISH/AS RECEIVED
PANEL 2		
PANEL 3		
PANEL 4		
PANEL 5		
PANEL 6		
BASE	304 SSTL	63 micro inch
FOOTING	302 SSTL	

NOTES AND TOLERANCES: (UNLESS OTHERWISE SPECIFIED)				CALIFORNIA INSTITUTE OF TECHNOLOGY MASSACHUSETTS INSTITUTE OF TECHNOLOGY		PART NAME	
1. INTERPRET DRAWING PER ASME Y14.5-1994. 2. REMOVE ALL SHARP EDGES, R.02 MIN. 3. DO NOT SCALE FROM DRAWING. 4. ALL MACHINING FLUIDS MUST BE FULLY SYNTHETIC, FULLY WATER SOLUBLE AND FREE OF SULFUR, SILICONE, AND CHLORINE.				SYSTEM <b>ADVANCED LIGO</b>		SUB-SYSTEM <b>AOS</b>	
DIMENSIONS ARE IN INCHES TOLERANCES: .XX ± .02 .XXX ± .005 ANGULAR ± N/A °				MATERIAL REFER TO TABLE		FINISH REFER TO TABLE	
				NEXT ASSY		DESIGNER C CONLEY 29 APR 2010	
				CHECKER N. KILPATRICK 18 AUG 2010		SIZE DWG. NO. <b>D D1002207</b>	
				APPROVAL		REV. v2	
				SCALE: 1:12		PROJECTION:	
				SHEET 1 OF 10			

D:\002207\aligo\aos\Oplev\RX Pier Weldment LH (PR3, SR3).PART PDM.REV:K.032.DRAWING.PDM.REV:K.035

D:\002207\dl\GO\_ACS\_Collev\_RK\_Pier\_Weldment\L1 (PES, SB3)\_PART PDM\_REV-X.032\_DRAWING\_PDM\_REV-X.035

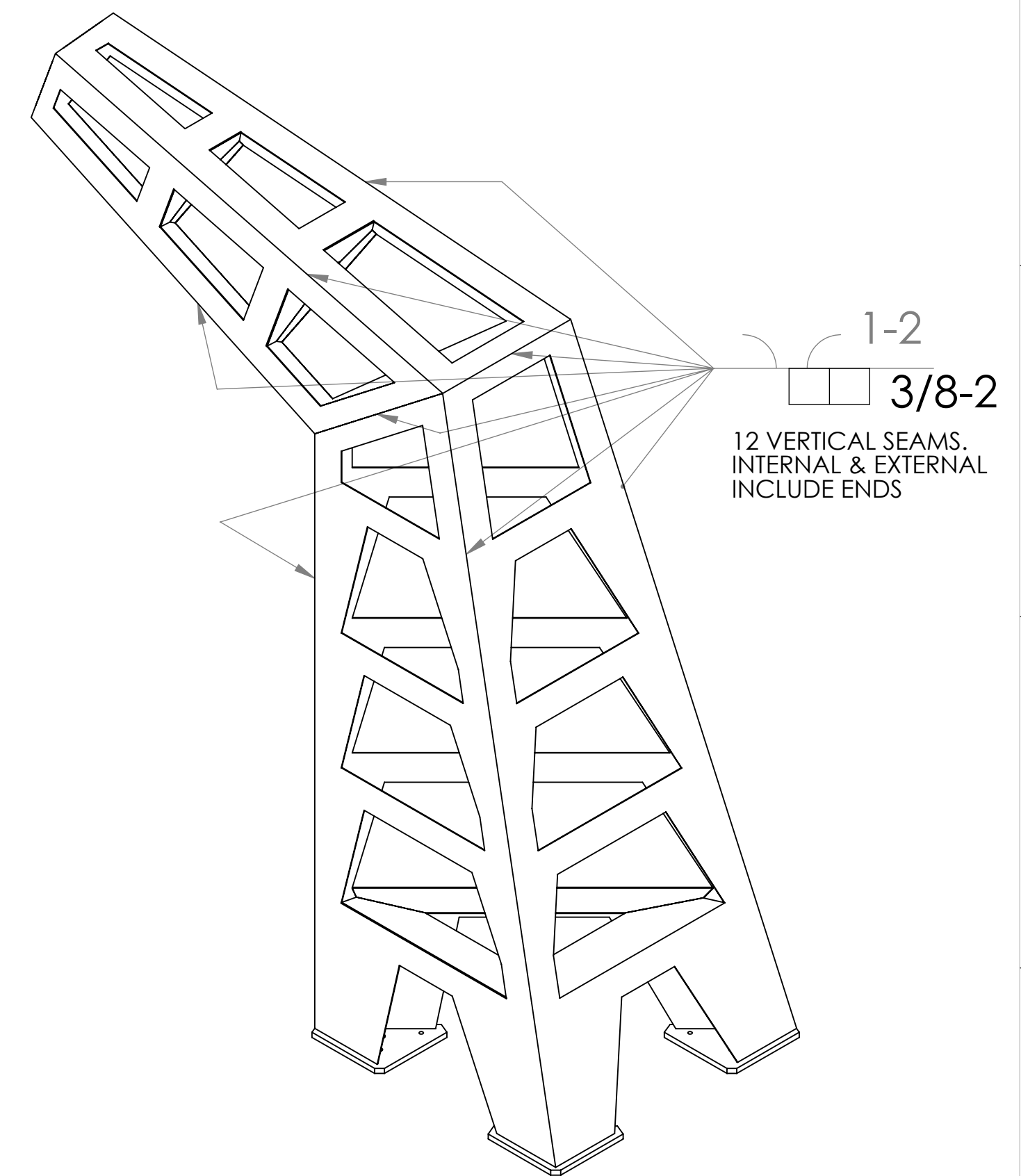
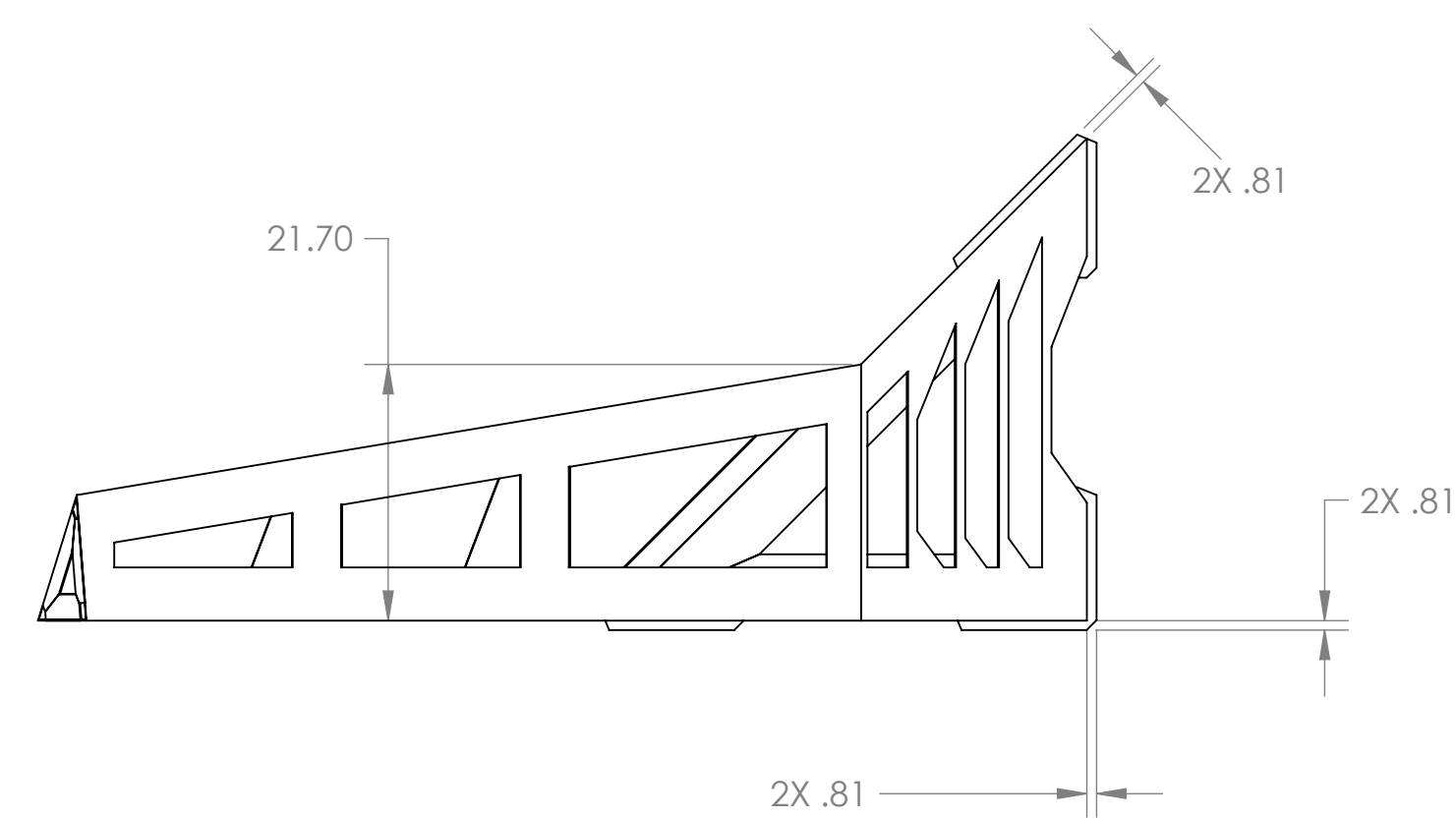
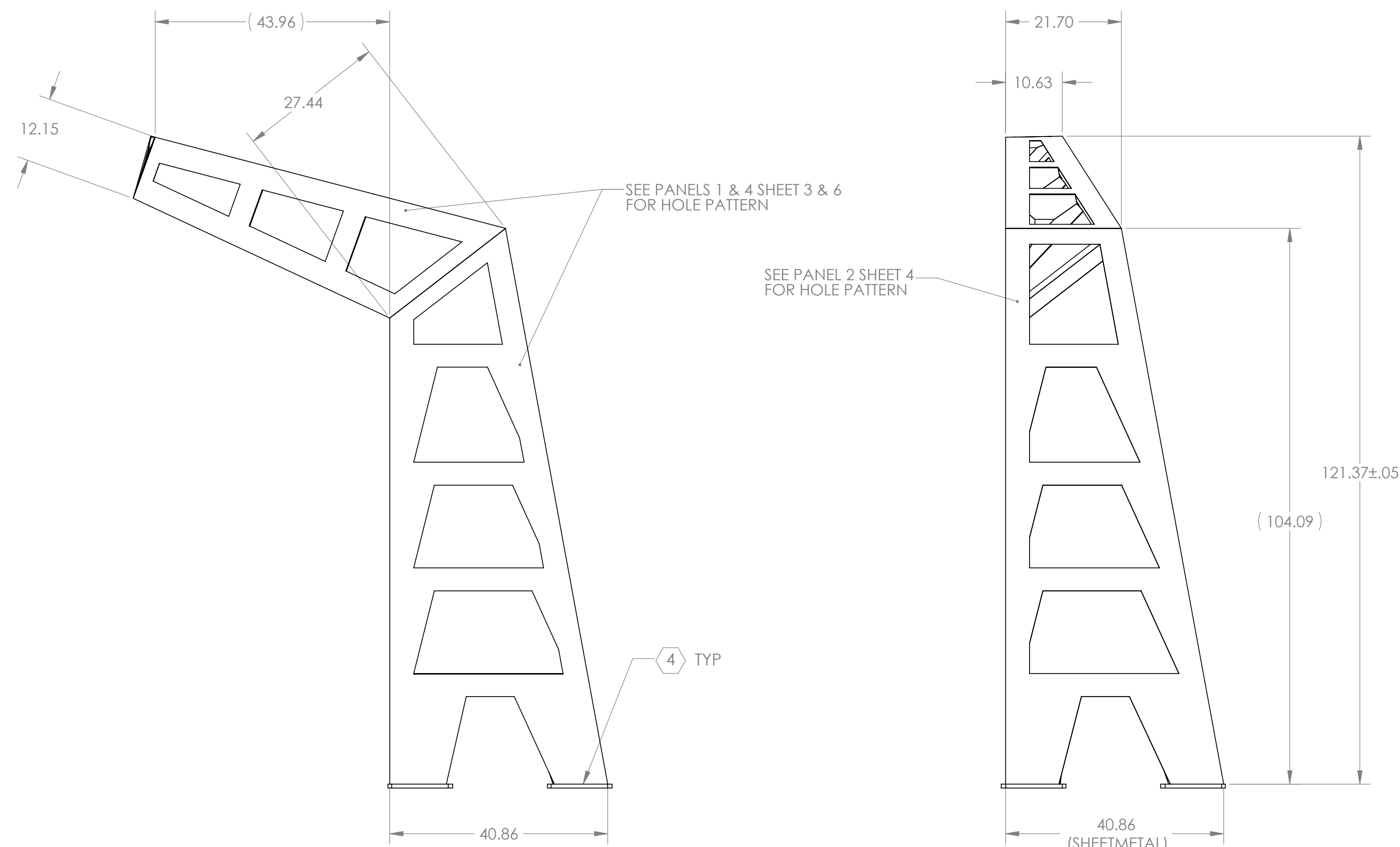
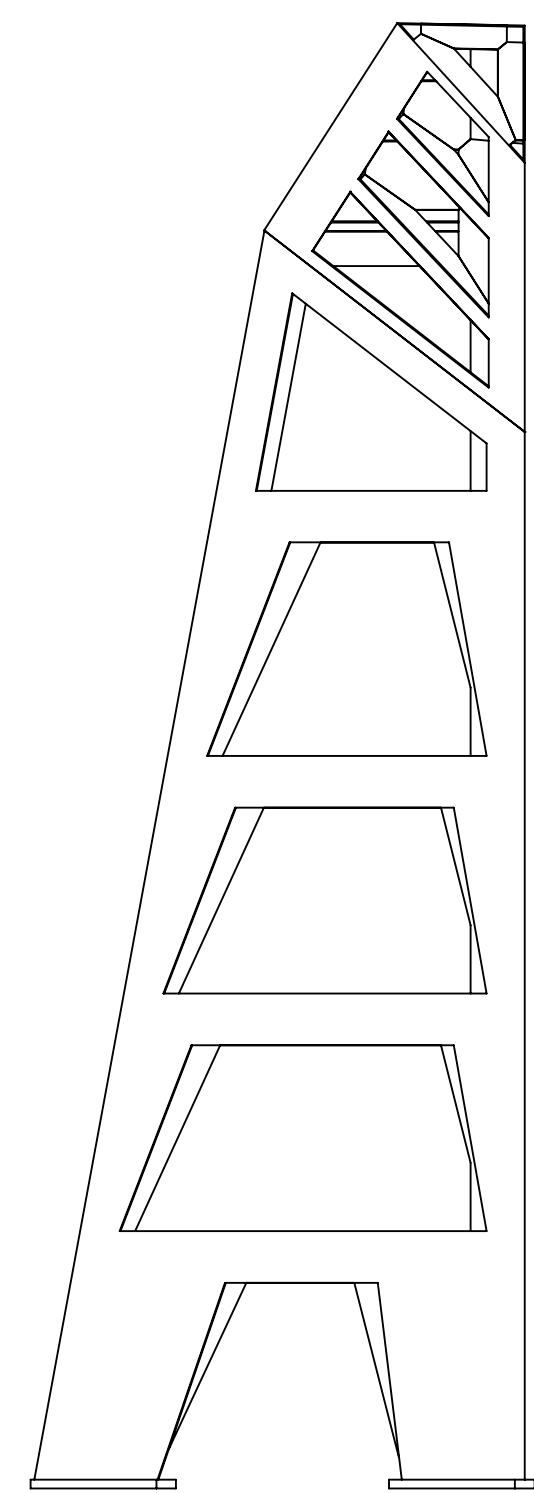

**WELDMENT**

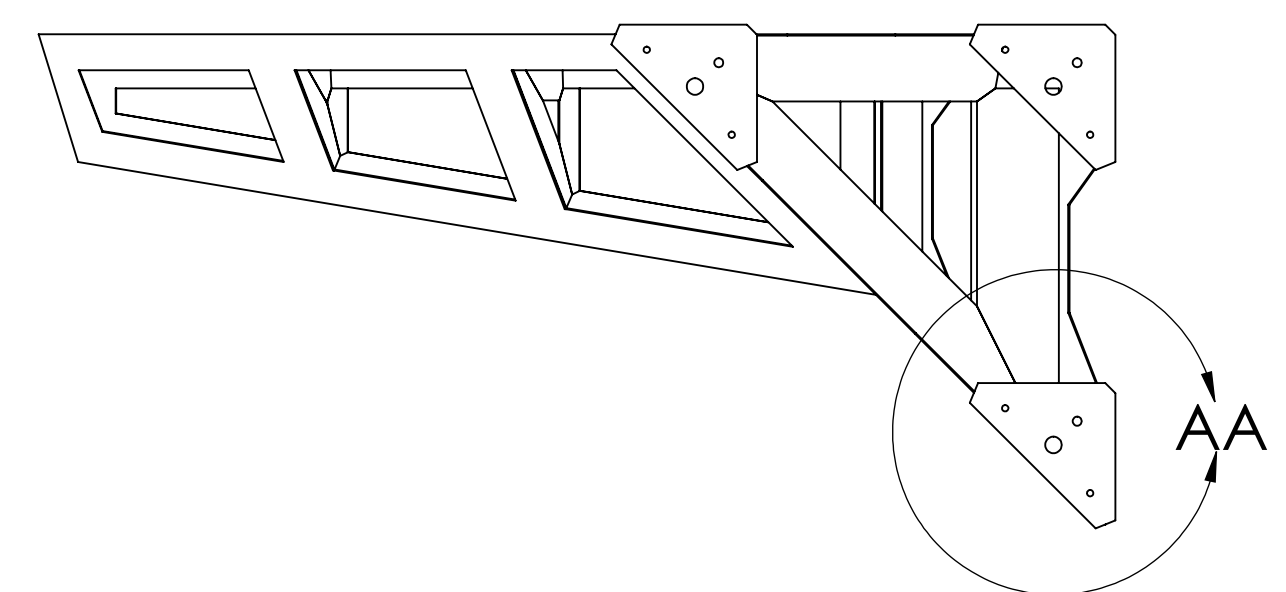

REMOVE FOOTING VIEW FOR CLARITY

<b>LIGO</b> CALIFORNIA INSTITUTE OF TECHNOLOGY MASSACHUSETTS INSTITUTE OF TECHNOLOGY	
SIZE DWG. NO.	REV.
<b>D</b> <b>D1002207</b>	<b>v2</b>
SCALE: 1:16	PROJECTION:  SHEET 2 OF 10

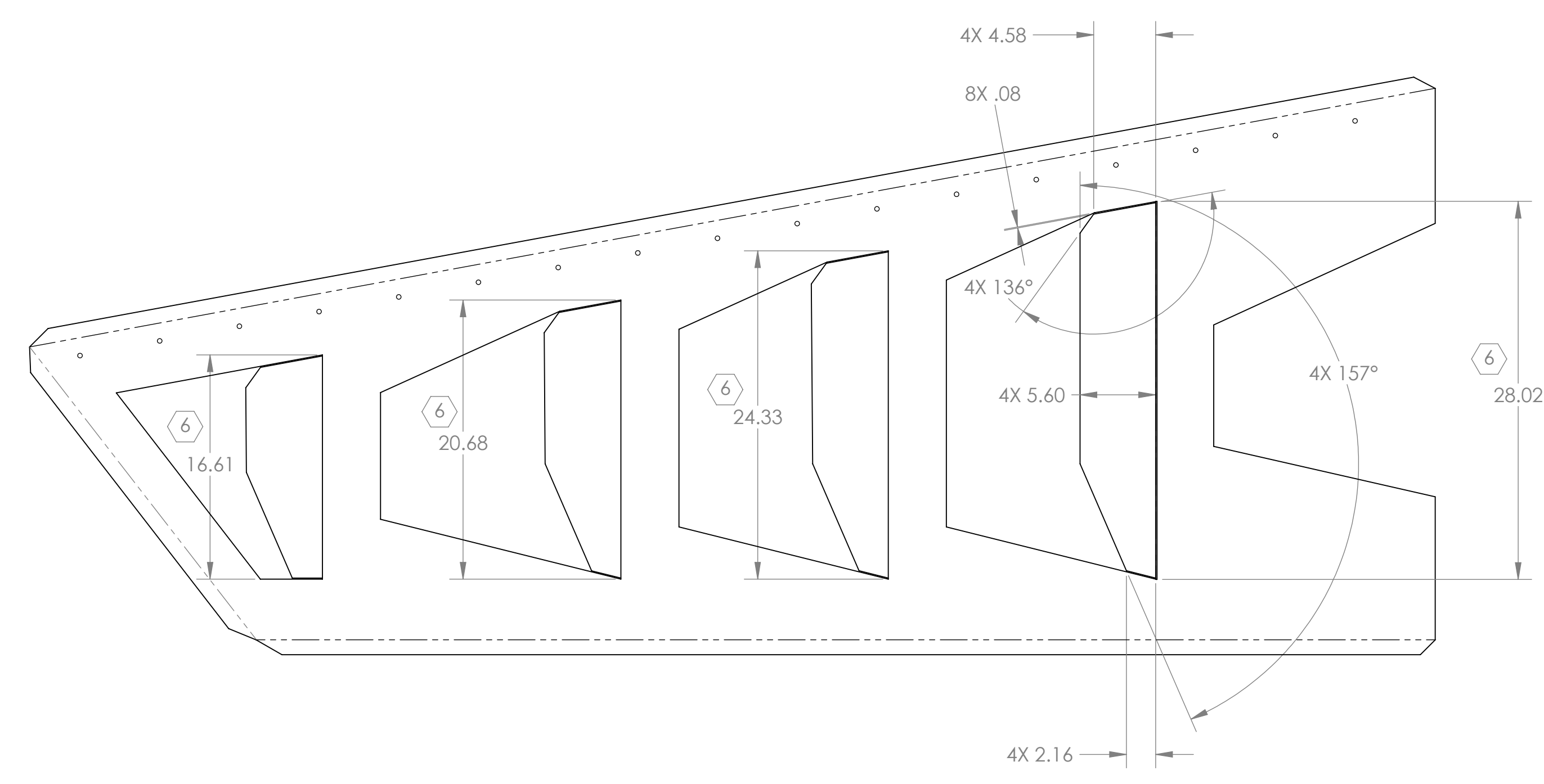
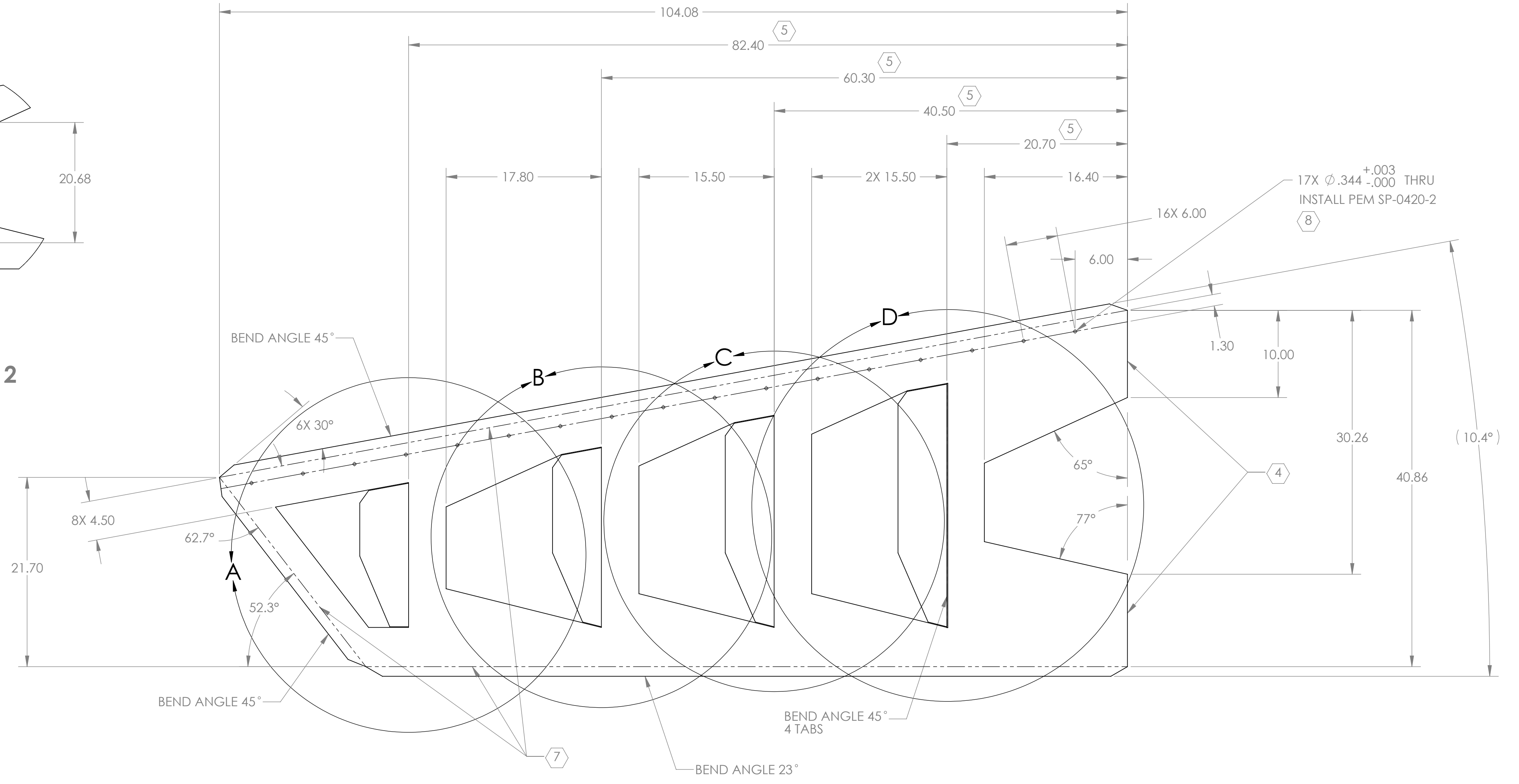
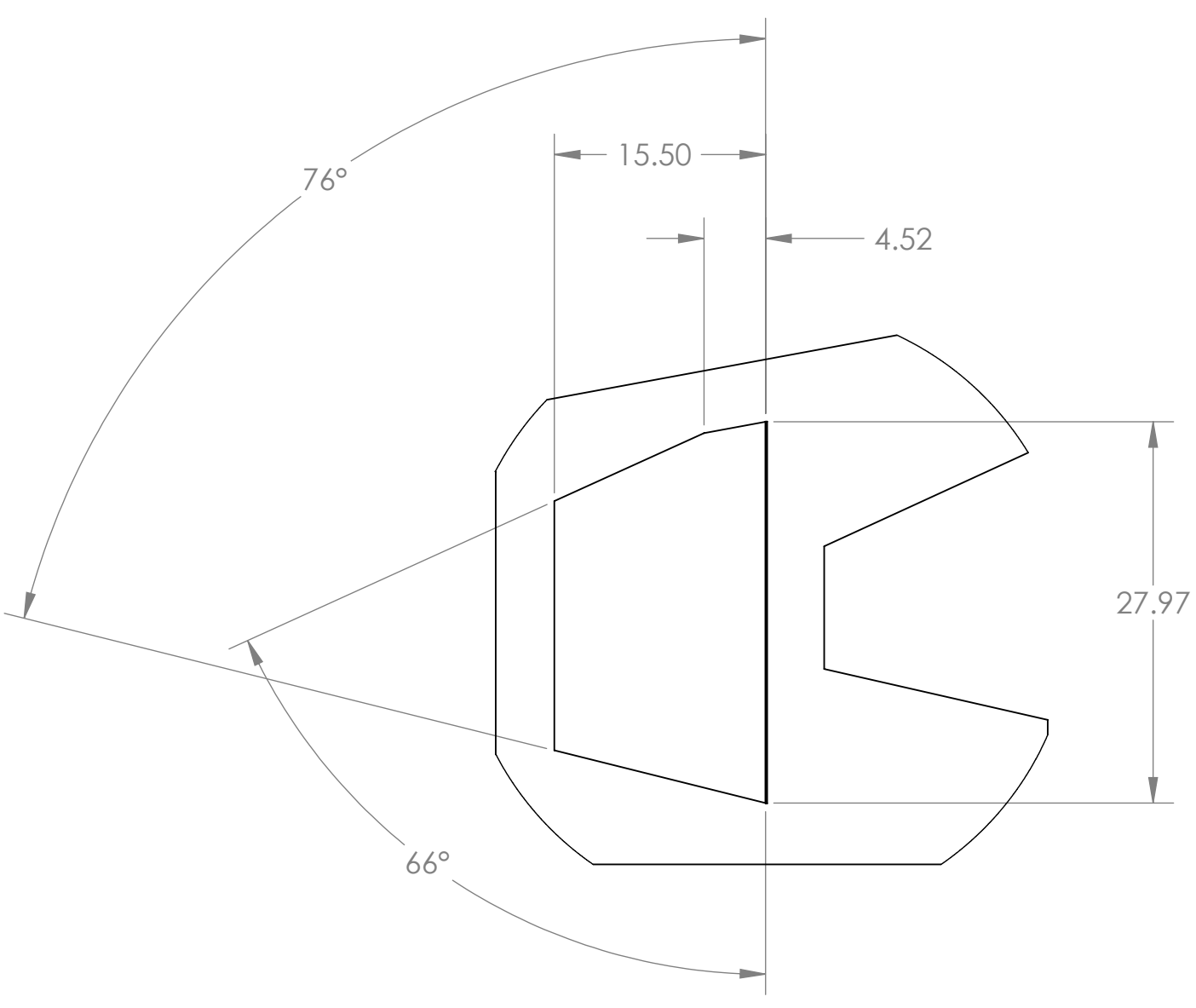
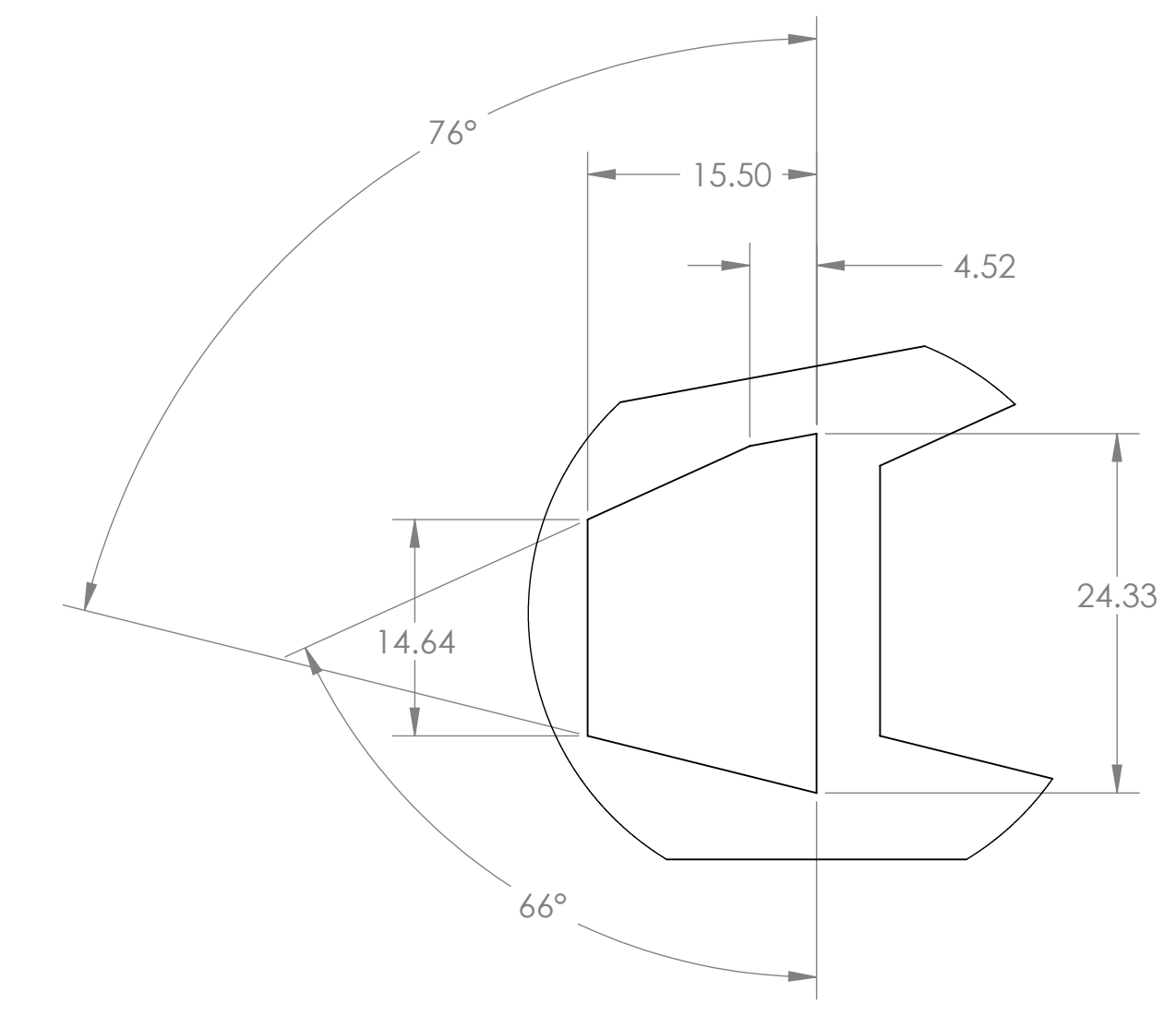
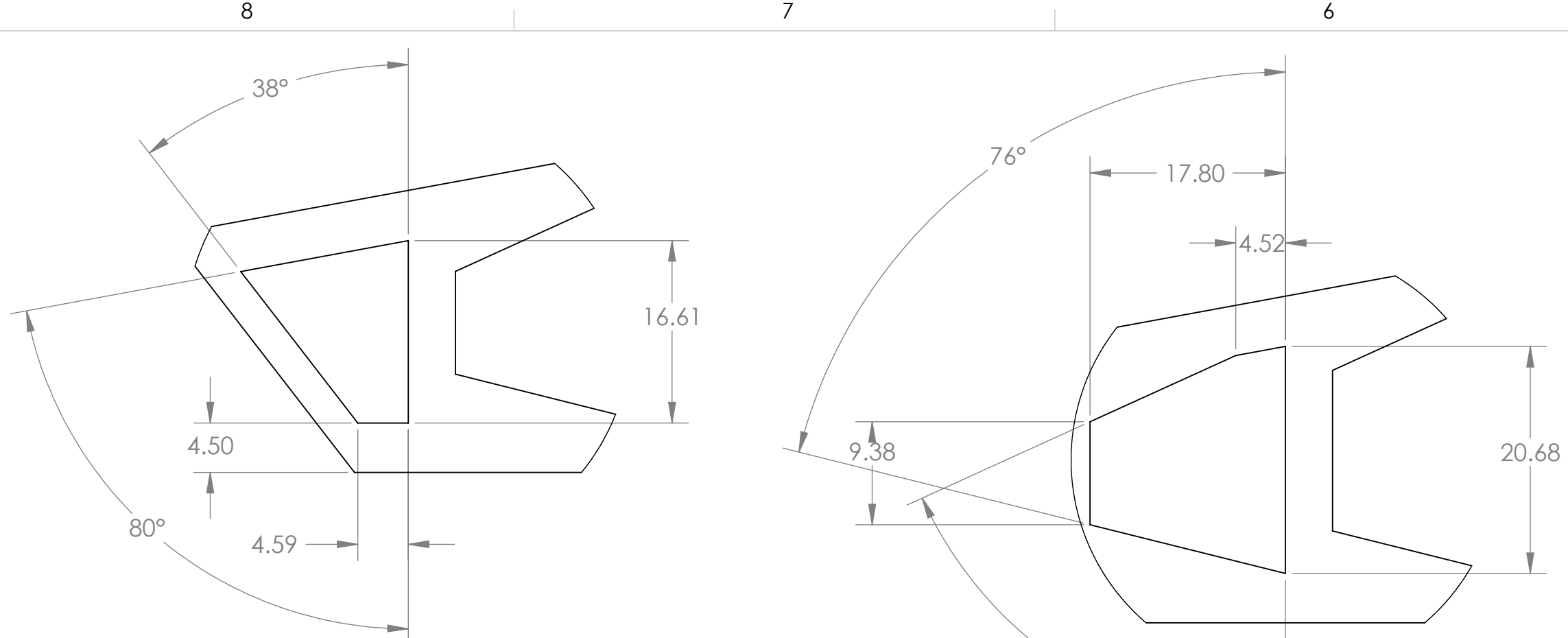

CALIFORNIA INSTITUTE OF TECHNOLOGY MASSACHUSETTS INSTITUTE OF TECHNOLOGY		
SIZE DWG. NO.	D D1002207	REV. v2
SCALE: 1:8	PROJECTION:	SHEET 3 OF 10

D1002207.dwg: ACS Octave: RX Pipe Weldment LH (PRL, S3), PART PDM REV: X.032, DRAWING PDM REV: X.035

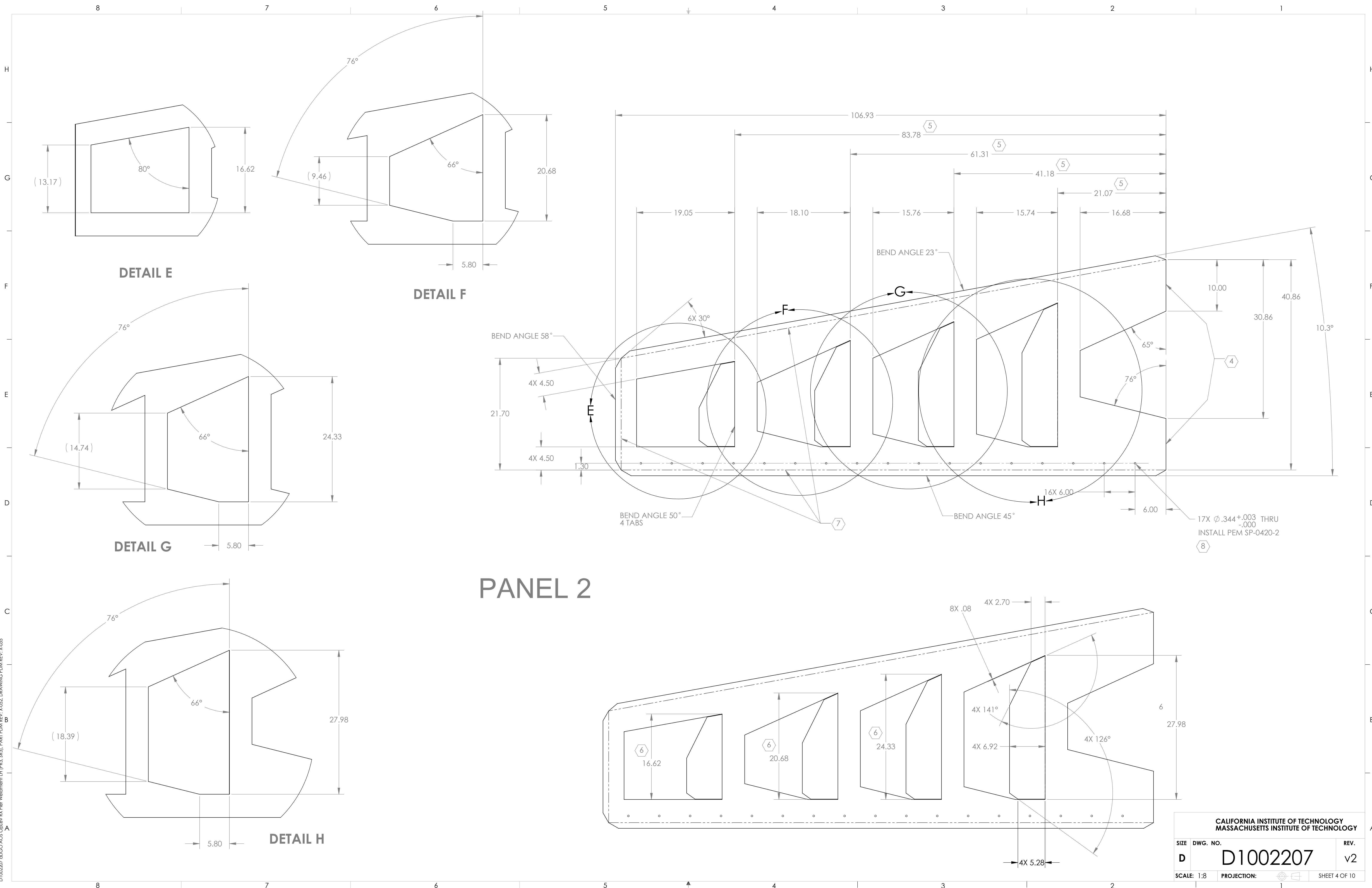

CALIFORNIA INSTITUTE OF TECHNOLOGY  
 MASSACHUSETTS INSTITUTE OF TECHNOLOGY

SIZE	DWG. NO.	REV.
D	D1002207	v2
SCALE: 1:8	PROJECTION:	SHEET 4 OF 10

D:\002207.dwg ACS Octave RP Pier Weldment LH (PES, S3), PART PDM REV: X.032, DRAWING PDM REV: X.035

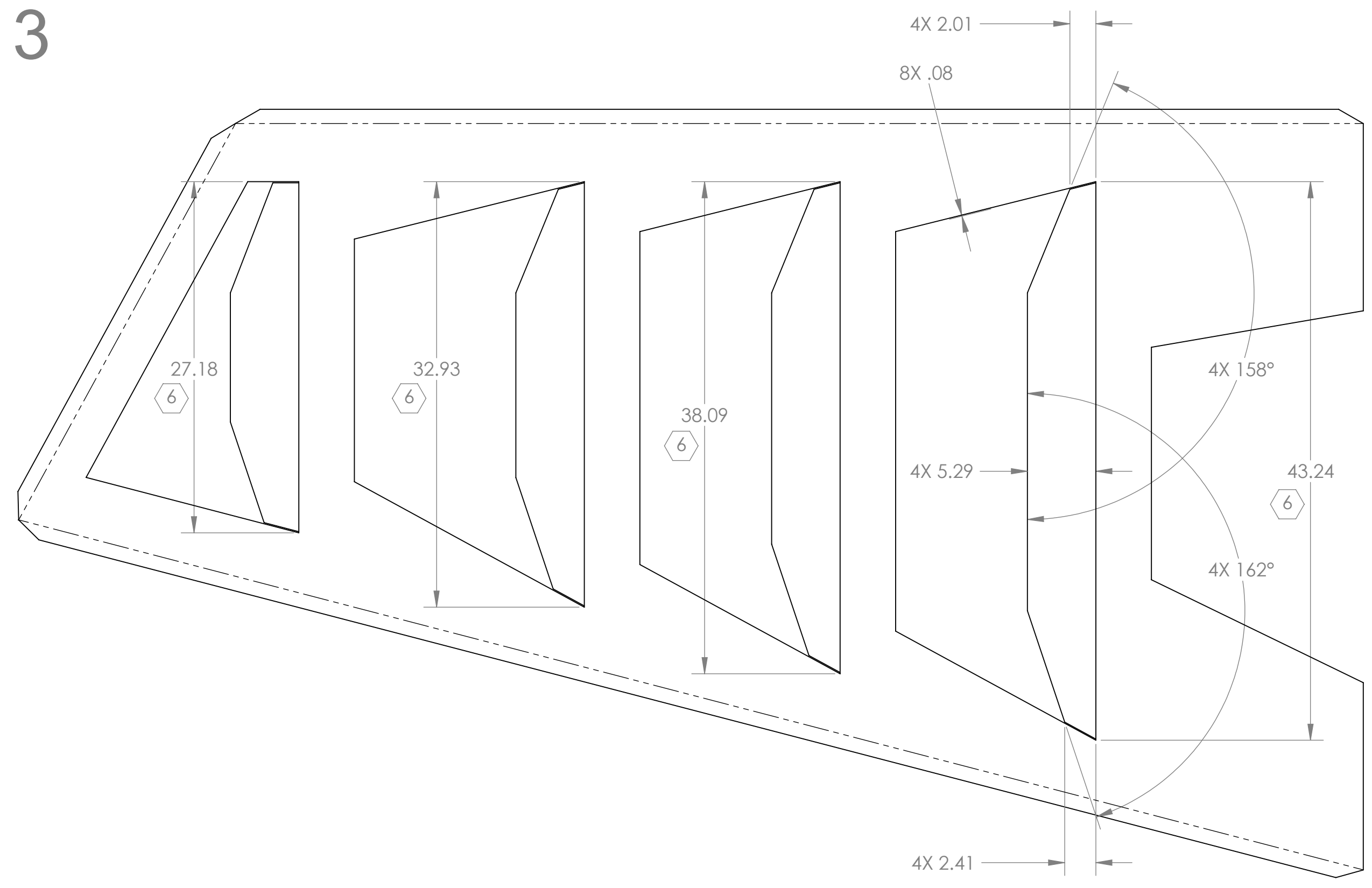
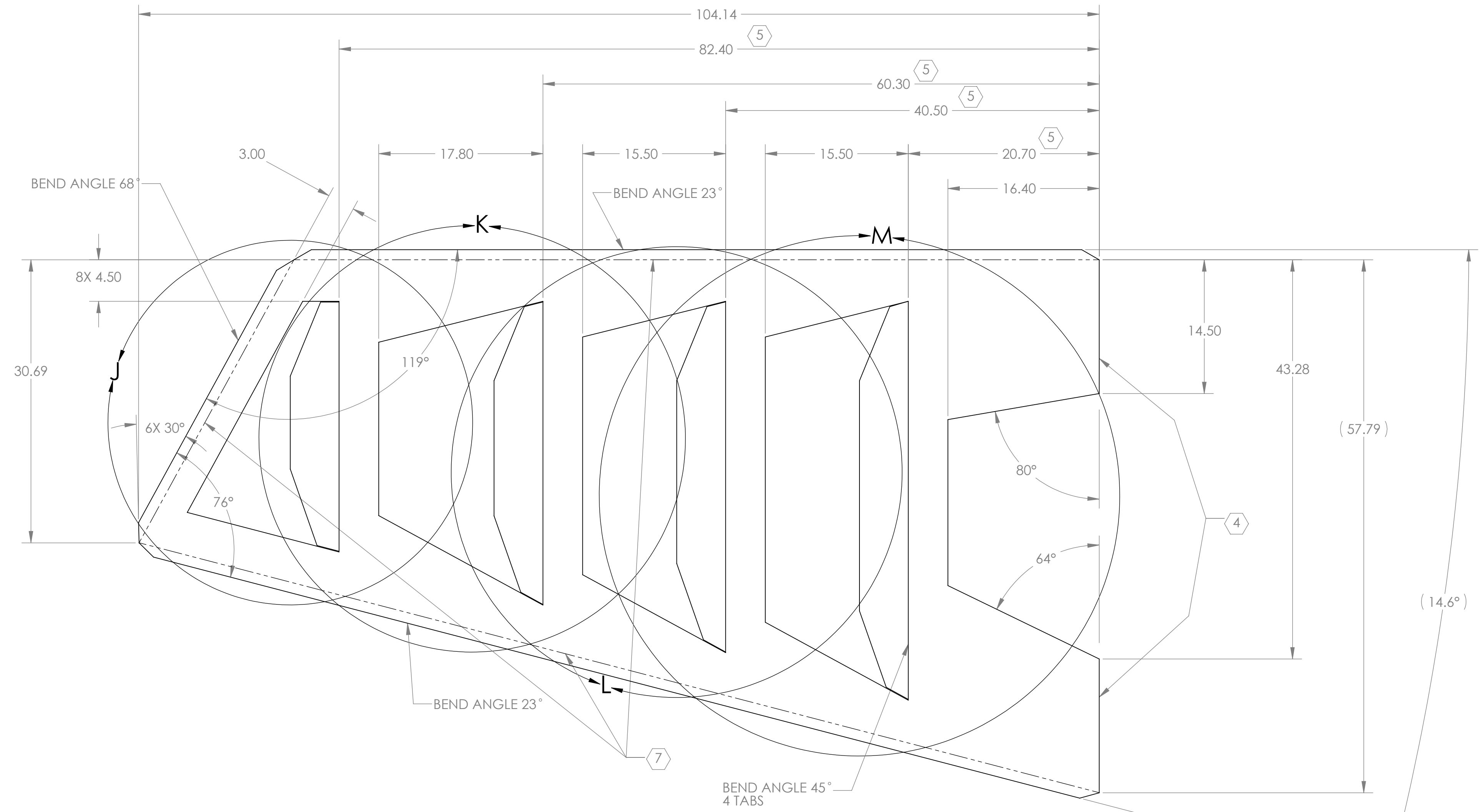
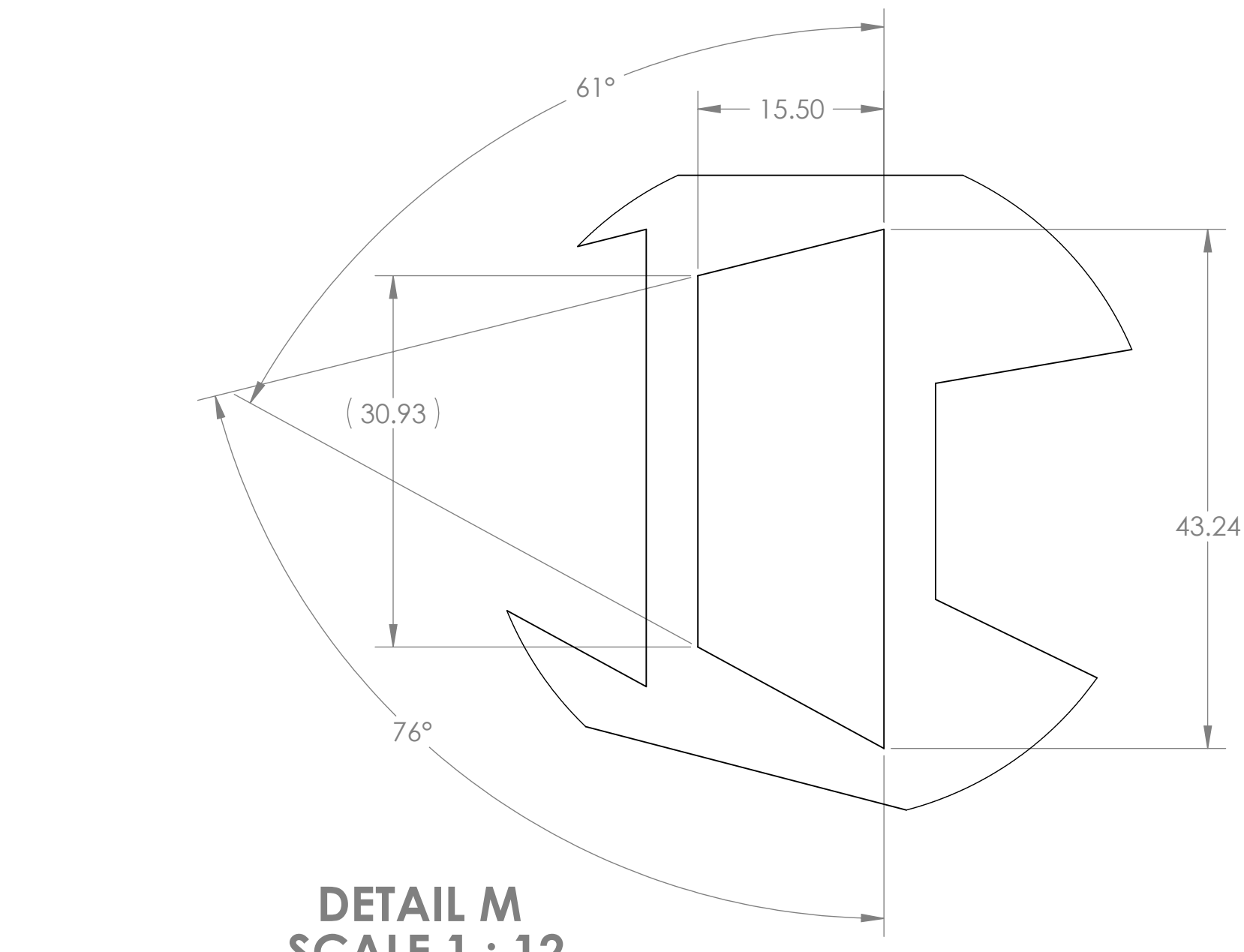
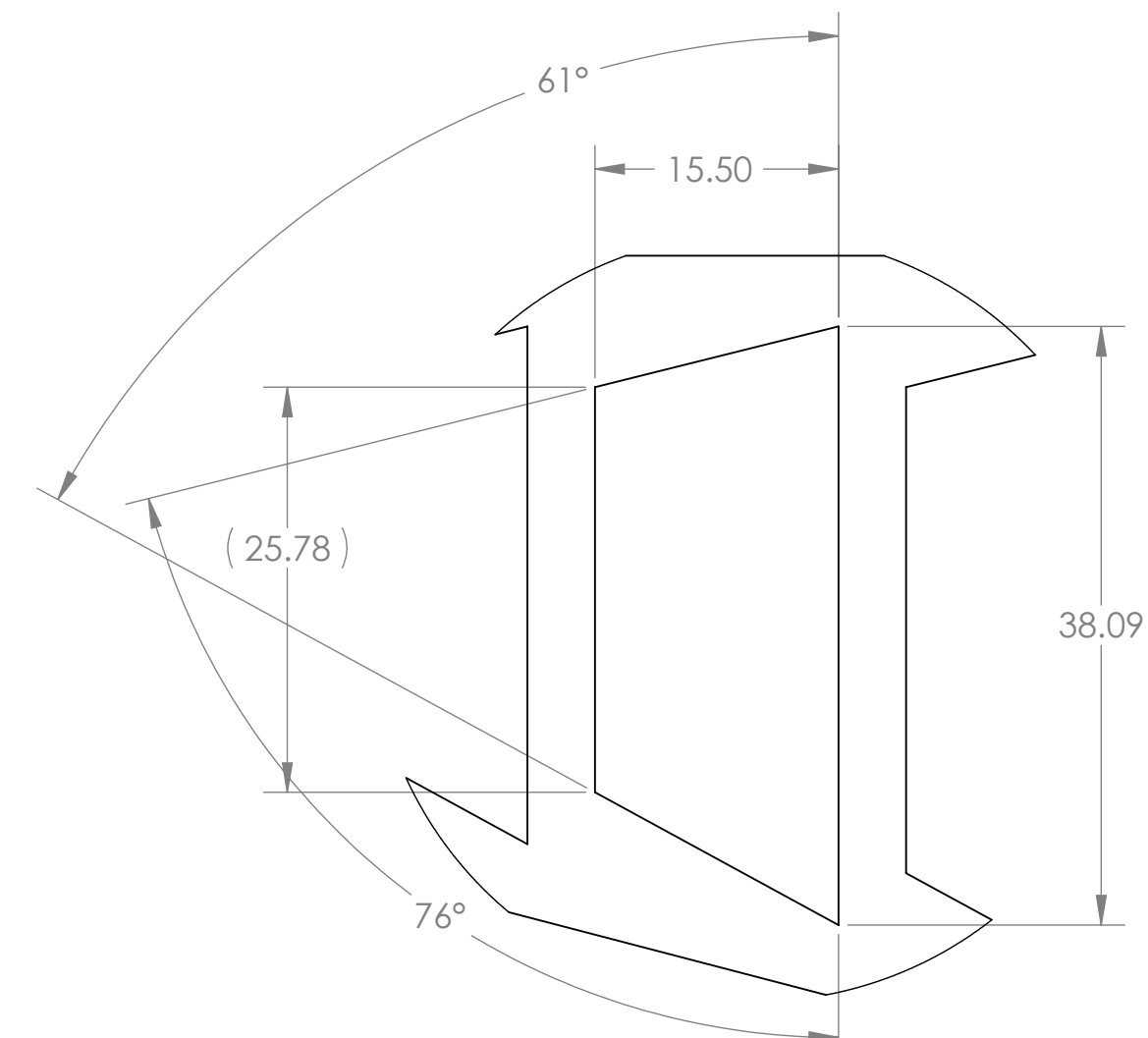
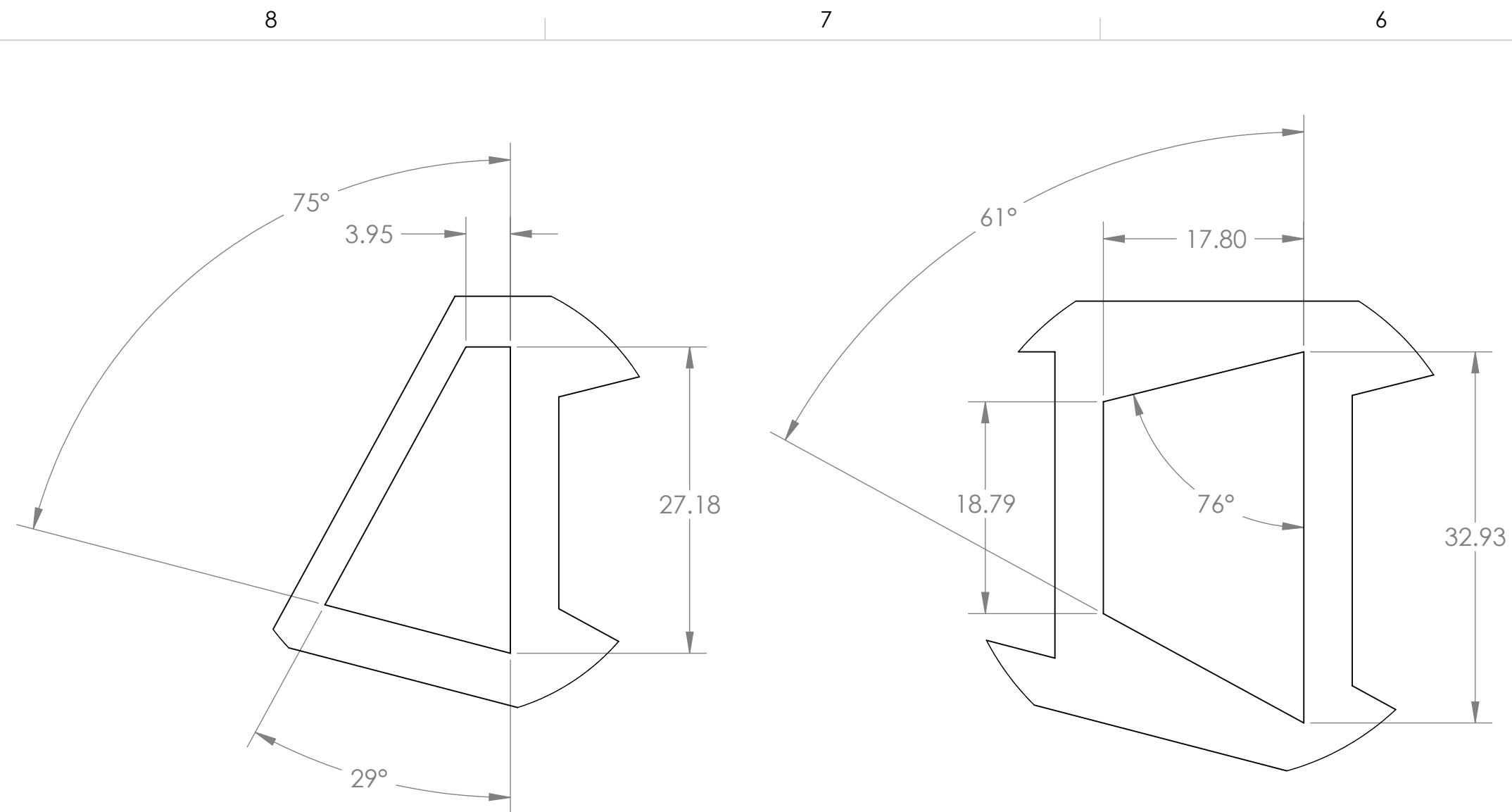

CALIFORNIA INSTITUTE OF TECHNOLOGY MASSACHUSETTS INSTITUTE OF TECHNOLOGY		
SIZE	DWG. NO.	REV.
D	D1002207	v2
SCALE: 1:8	PROJECTION:	SHEET 5 OF 10

D:\002207.dwg ACS Octlev-RX Pipe Weldment LH (PREL\_S33).PART PDM\_REV-X.032.DRAWING.PDM\_REV-X.035



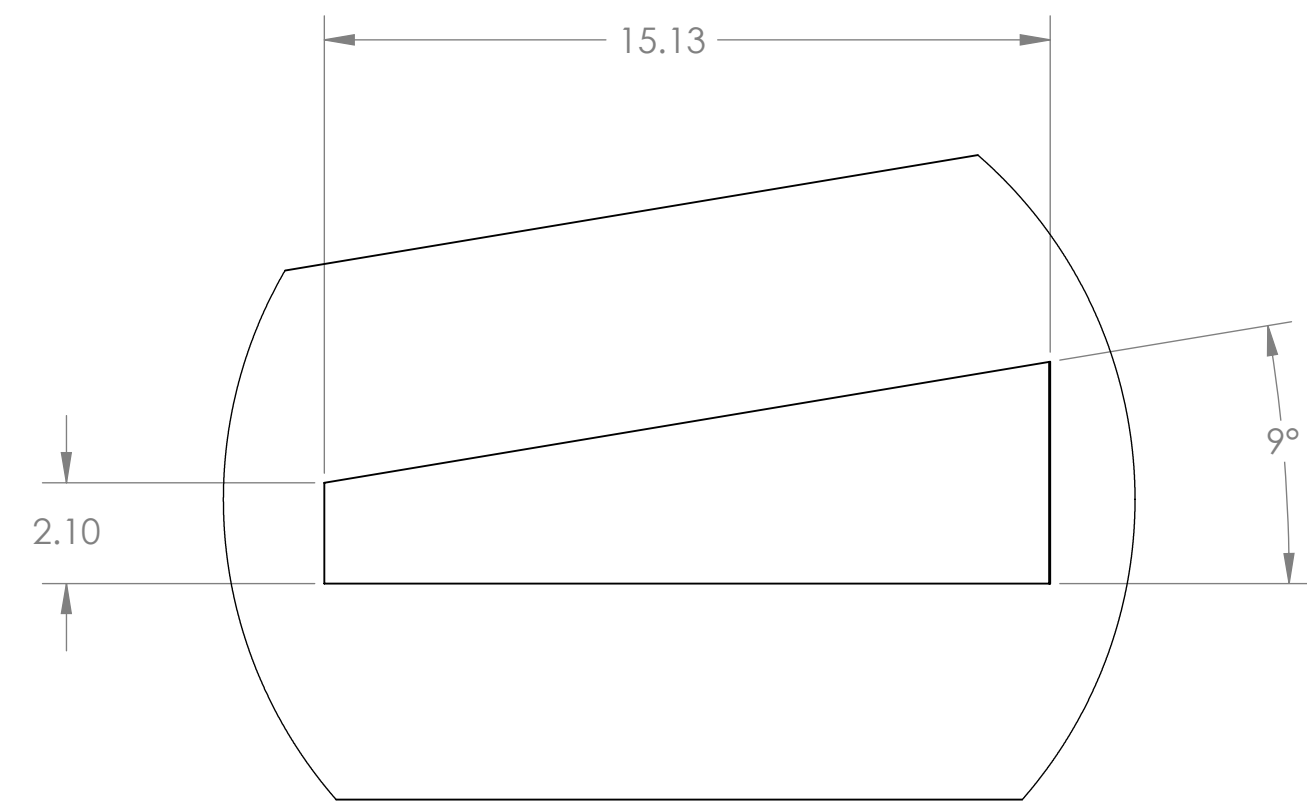

**DETAIL T**  
SCALE 1 : 4

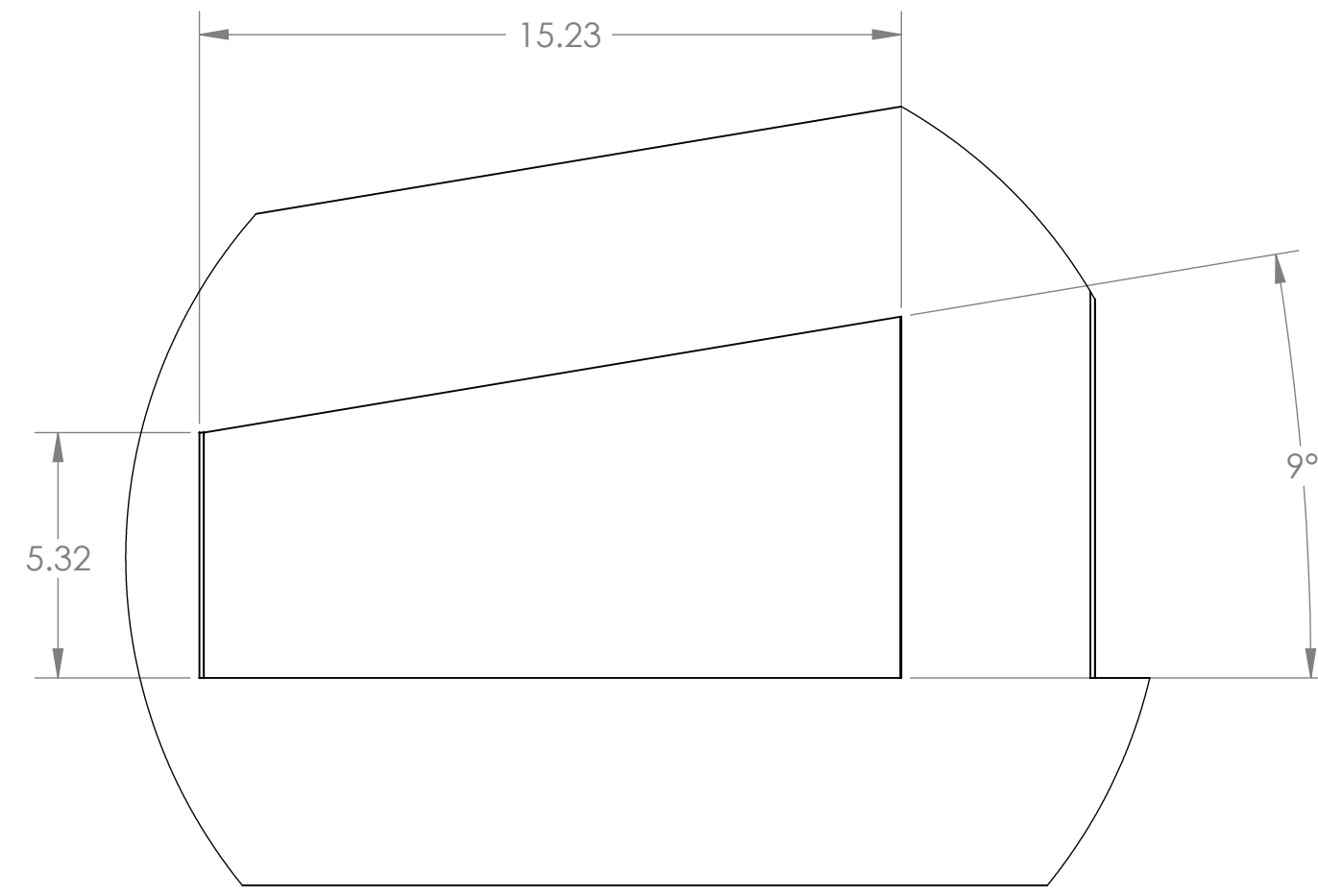

**DETAIL U**  
SCALE 1 : 4

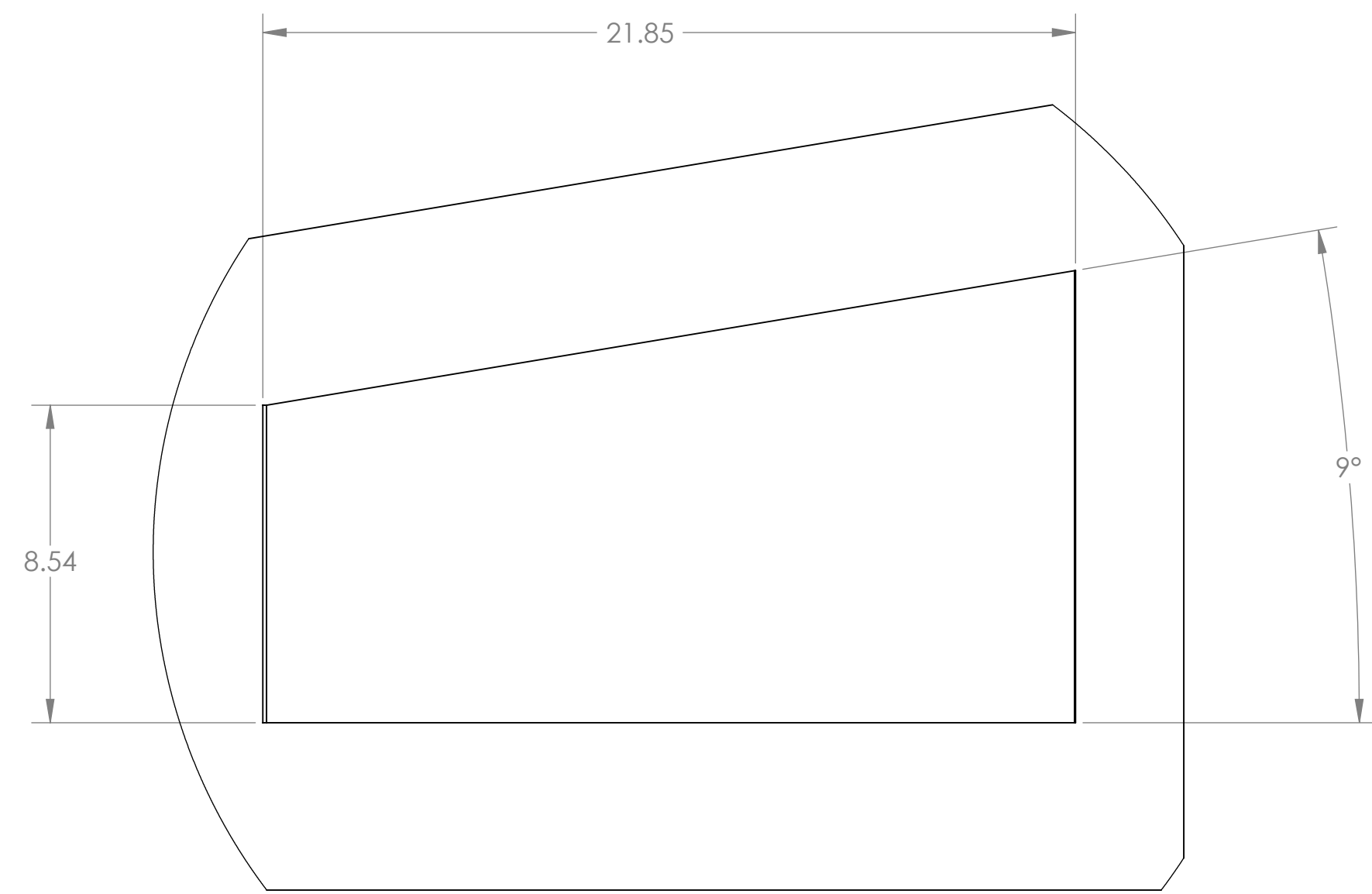

**DETAIL V**  
SCALE 1 : 4

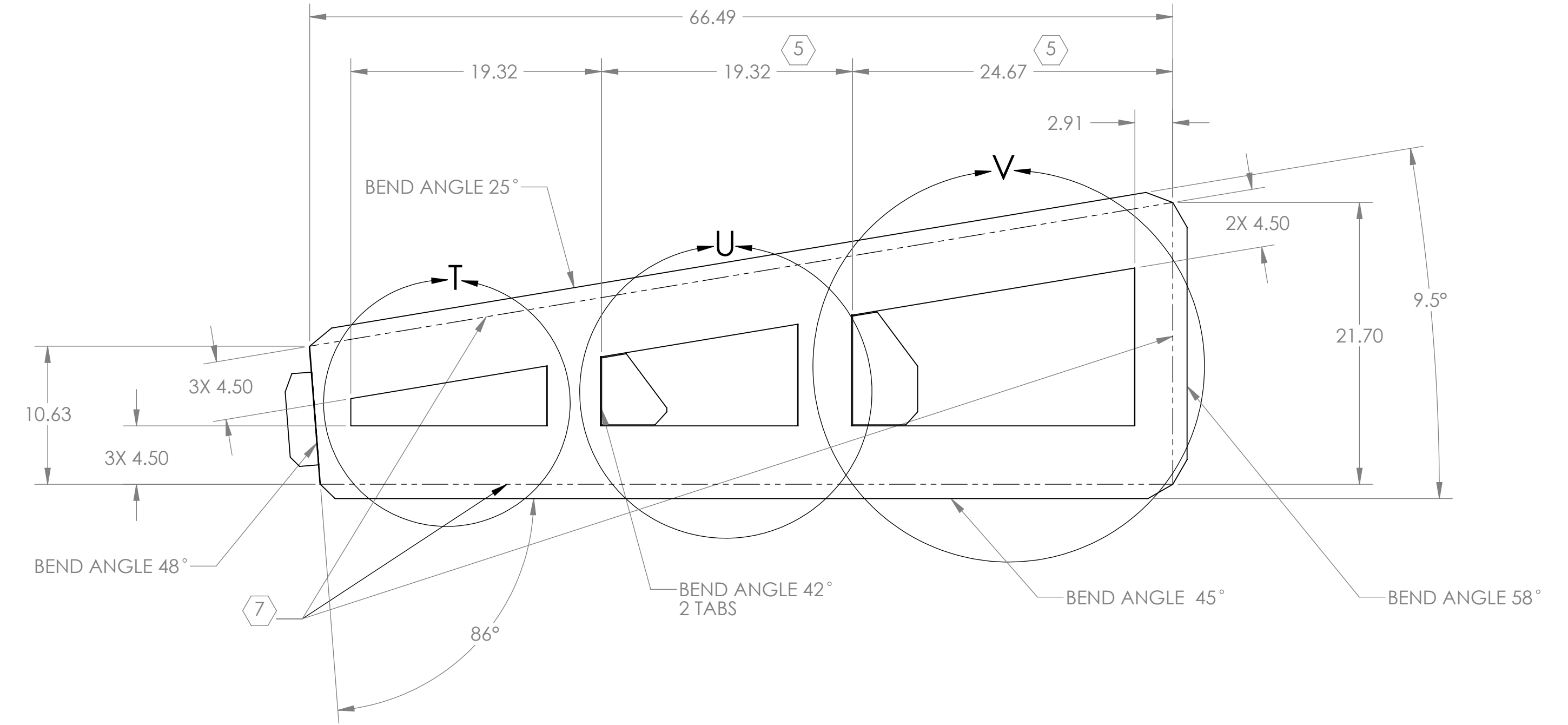

**PANEL 5**

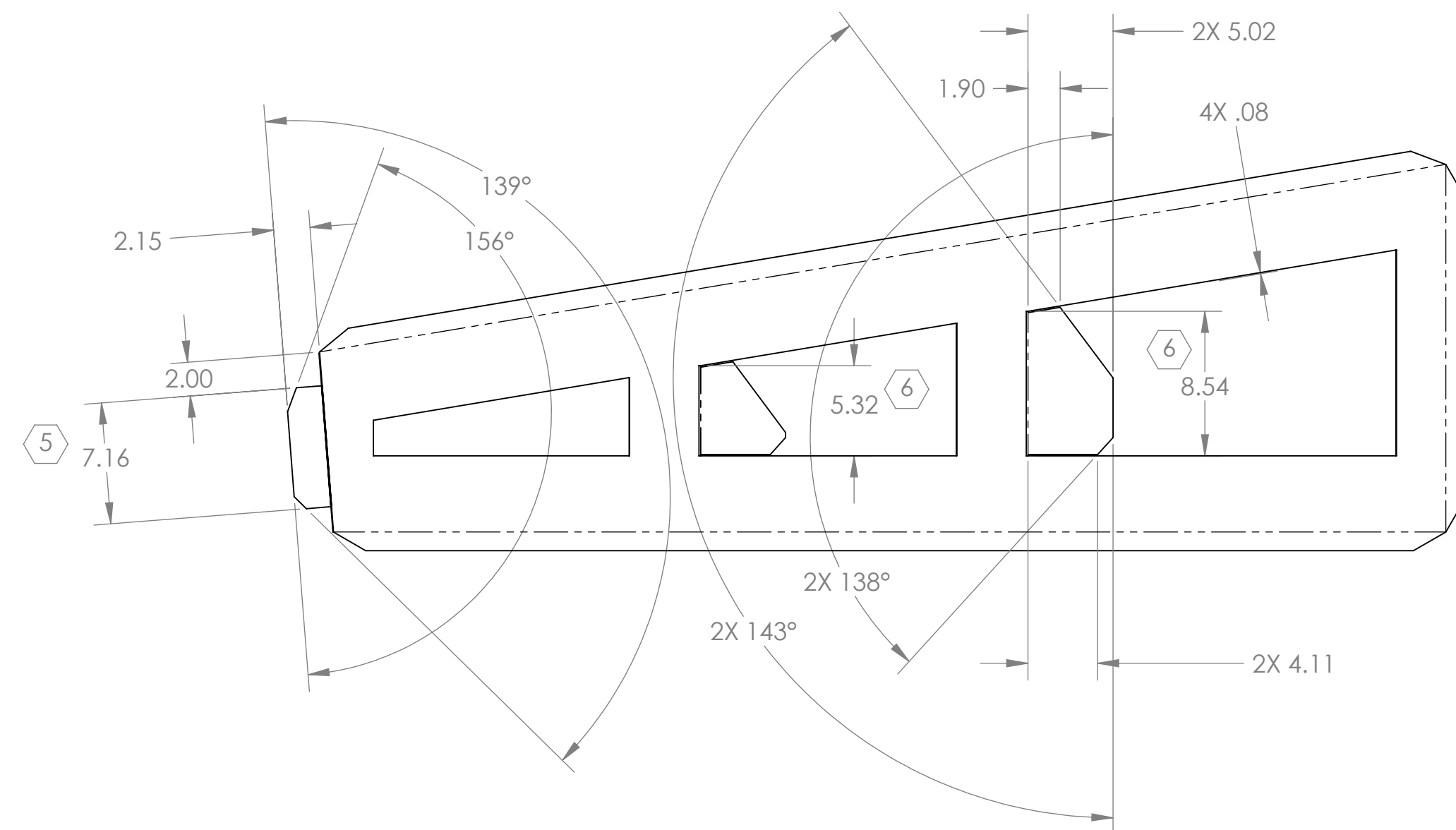

CALIFORNIA INSTITUTE OF TECHNOLOGY MASSACHUSETTS INSTITUTE OF TECHNOLOGY		
SIZE	DWG. NO.	REV.
D	D1002207	v2
SCALE: 1:8	PROJECTION:	SHEET 7 OF 10

D:\002207\duco\ACS\Ocler\RX Pier Weldment LH (PES, SBJ)\_PART PDM\_REV-X.032.DRAWING-PDM\_REV-X.035

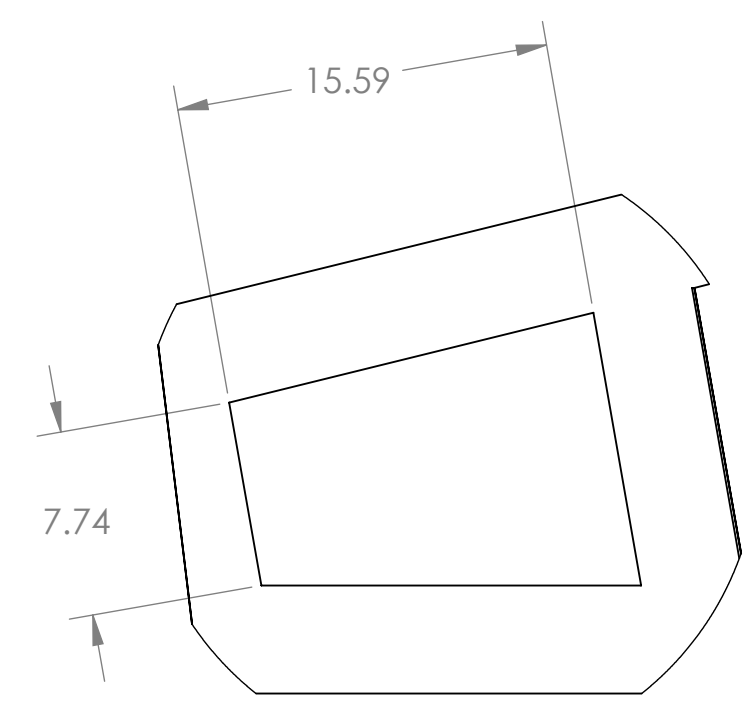

**DETAIL W**

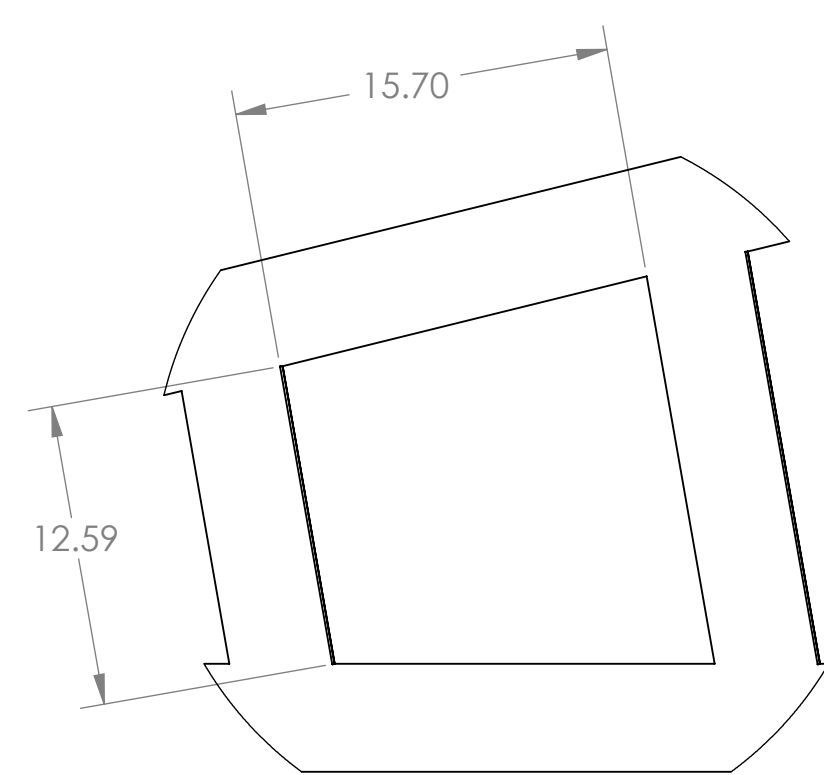

**DETAIL Y**

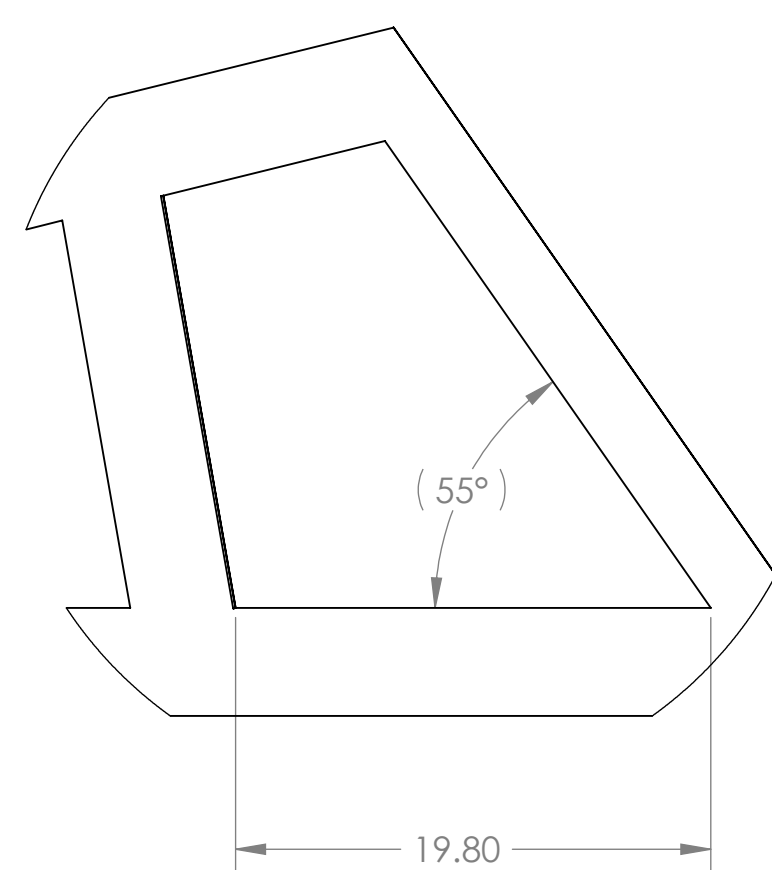

**DETAIL Z**

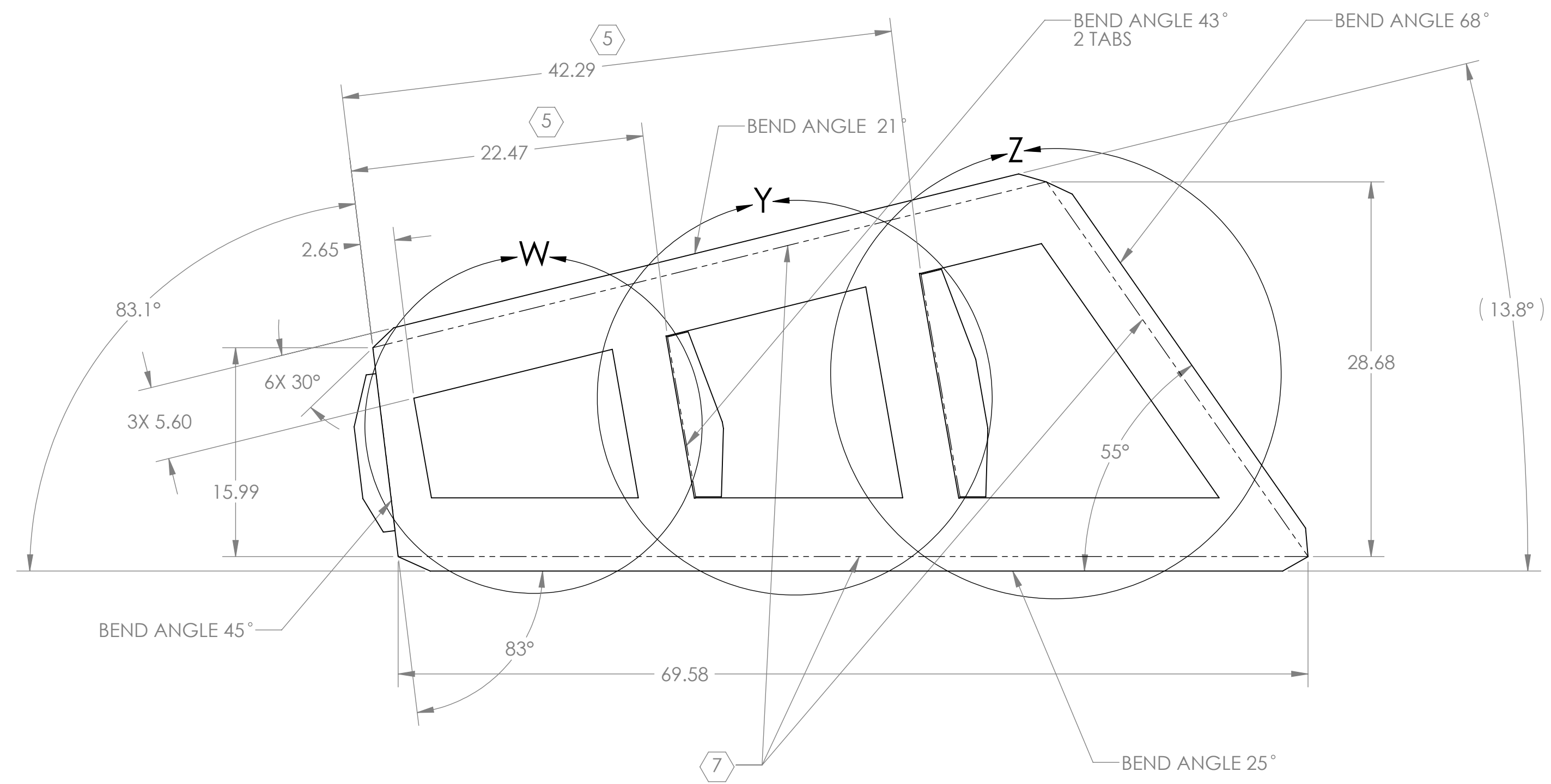

**PANEL 6**

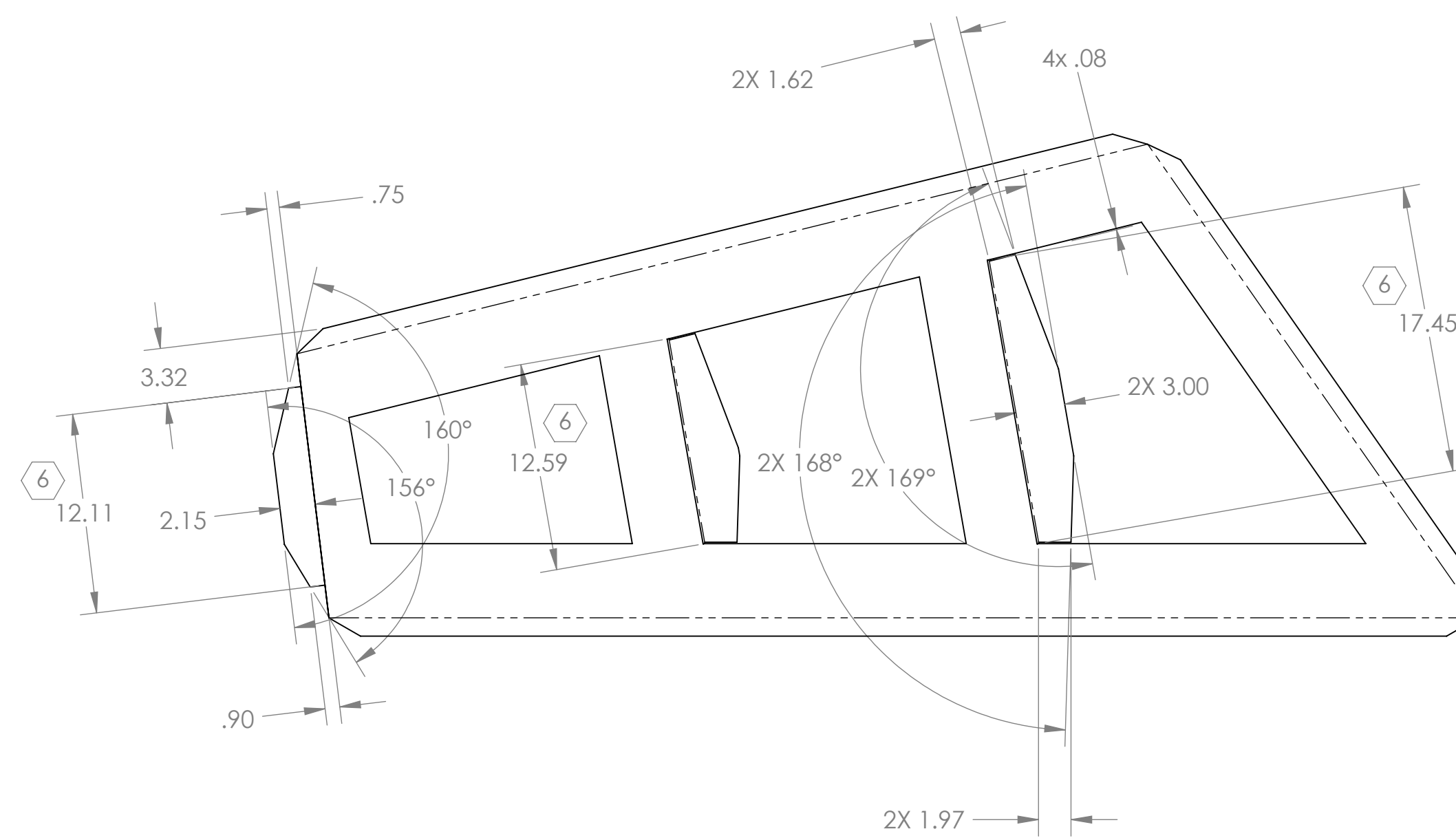

CALIFORNIA INSTITUTE OF TECHNOLOGY MASSACHUSETTS INSTITUTE OF TECHNOLOGY		
SIZE	DWG. NO.	REV.
D	D1002207	v2
SCALE: 1:8	PROJECTION:	SHEET 8 OF 10

D:\002207.dwg ACS Oct 14 10:54 AM P:\Pier Weldment LH (PES, SBJ) PART PDM REV: X.032 DRAWING PDM REV: X.035







**NOTES CONTINUED:**

1. STRUCTURE SHOWN & DIMENSIONED WITH SHARP ADJOINING PANEL CORNERS. ACTUAL PANELS TO BE BENT SIMILARLY TO D1001292 PANELS AT ADJOINING CORNERS. DIMENSIONS TO SAID SHARP CORNERS ARE FOR ESTABLISHING STRUCTURAL SIZE & SHAPE ONLY.
2. ALL BEND RADII .125.
- ③ BASES TO BE FASTENED TO FOOTING DURING WELDING OF BASES TO PANELS. FASTEN EACH BASE USING THREE 1/2-20 UNF SCREWS TO TAPPED HOLES IN FOOTING. FOOTING MUST BE REMOVABLE & RE-ATTACHABLE. POST-WELD, WITH NO BINDING OF SCREWS. WELDMENT TO BE DELIVERED WITH FOOTING ATTACHED.
- ④ WARPAGE OF BASES & FOOTING TO BE MINIMIZED USING PREFERRED METHODS, IE. SCALOPS(STITCH WELDING (50%)), HEAT SINKING.
5. THIS UNIT IS MIRROR IMAGE OPPOSITE OF D1002207. SEE DRAWING D1002207 FOR COMPLETE CONSTRUCTION DETAILS.

REV.	DATE	DCN #	DRAWING TREE #
v1	19 AUG 2010	E1000182-v1	-
-	-	-	-
-	-	-	-

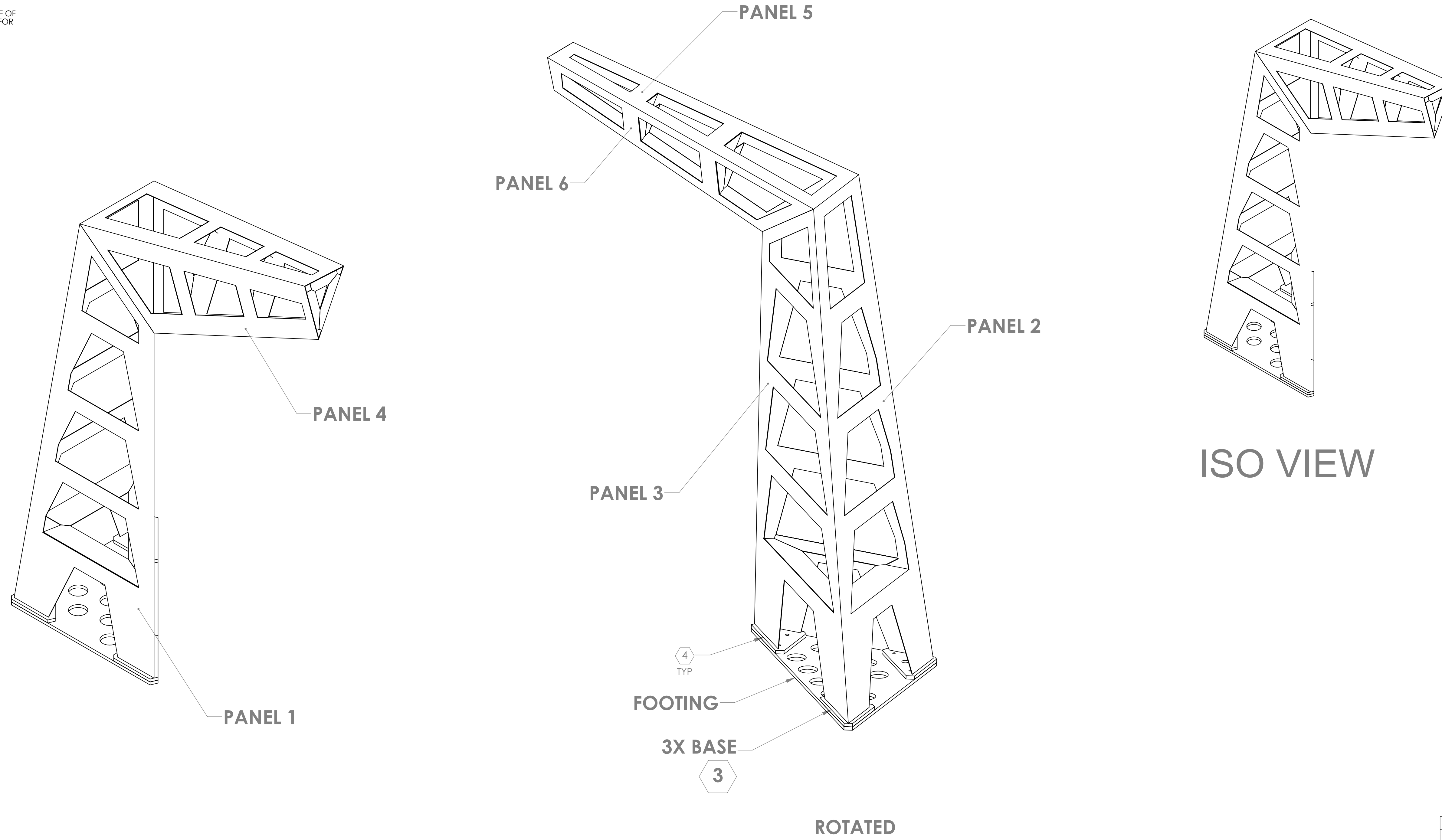

PART	MATERIAL	FINISH
PANEL 1	304 SST SHEET, 12 GAUGE	STOCK FINISH/AS RECEIVED
PANEL 2		
PANEL 3		
PANEL 4		
PANEL 5		
PANEL 6		
BASE	304 SSTL	63 micro inch
FOOTING	302 SSTL	

DIMENSIONS ARE IN INCHES TOLERANCES: .XX ± .02 .XXX ± .005 ANGULAR ± N/A °		<b>NOTES AND TOLERANCES: (UNLESS OTHERWISE SPECIFIED)</b> 1. INTERPRET DRAWING PER ASME Y14.5-1994. 2. REMOVE ALL SHARP EDGES, R.02 MIN. 3. DO NOT SCALE FROM DRAWING. 4. ALL MACHINING FLUIDS MUST BE FULLY SYNTHETIC, FULLY WATER SOLUBLE AND FREE OF SULFUR, SILICONE, AND CHLORINE.		<b>CALIFORNIA INSTITUTE OF TECHNOLOGY</b> <b>MASSACHUSETTS INSTITUTE OF TECHNOLOGY</b>		<b>PART NAME</b> <b>ALIGO AOS OPLEV</b> <b>RX PIER WELDMENT RH (SR3)</b>	
<b>MATERIAL</b> REFER TO TABLE		<b>FINISH</b> REFER TO TABLE		<b>SYSTEM</b> ADVANCED LIGO		<b>SUB-SYSTEM</b> AOS	
<b>DESIGNER</b> C CONLEY		<b>CHECKER</b> N. KILPATRICK		<b>DATE</b> 29 APR 2010		<b>SIZE</b> D	
<b>APPROVAL</b>		<b>DATE</b> 19 AUG 2010		<b>DWG. NO.</b> D1002208		<b>REV.</b> v1	
<b>SCALE:</b> 1:12		<b>PROJECTION:</b>		<b>SHEET 1 OF 1</b>			

D1002208.dwg: AOS Oplev: RX Pier Weldment RH (SR3) - H1, L1, PART PDM REV: X-003, DRAWING PDM REV: X-005

- NOTES CONTINUED:**
- ⑤ SCRIBE, ENGRAVE, OR MECHANICALLY STAMP (NO INKS OR DYES) DRAWING PART NUMBER, REVISION (AND VARIANT OR TYPE IF APPLICABLE) ON NOTED SURFACE OF PART FOLLOWED ON THE NEXT LINE WITH A THREE DIGIT SERIAL NUMBER. SERIAL NUMBERS START AT 001 FOR THE FIRST ARTICLE AND PROCEED CONSECUTIVELY. USE MINIMUM 0.12" HIGH CHARACTERS, UNLESS THE SIZE OF THE PART DICTATES SMALLER CHARACTERS. A VIBRATORY TOOL MAY BE USED. EXAMPLE: DXXXXXX-VY, TYPE-XX, S/N XXX
  - ⑥ AFTER COMPLETION OF THE WELDMENT, MACHINE AT TOP OF ITEM 3 TO NOTED SPECIFICATIONS IF NECESSARY. LEVEL THE UPPER FACE OF ITEM 3 (SQUARE WITH MACHINING HEAD) BEFORE MACHINING.
  - ⑦ FASTEN ITEMS 2 TO D1000434 FOOTING BEFORE APPLYING NOTED WELDS, TO ENSURE ALIGNMENT. FOR EACH ITEM 2, USE THREE 1/2-20 UNF SCREWS TO TAPPED HOLES IN FOOTING. FOOTING MUST BE REMOVABLE & RE-ATTACHABLE POST-WELD, WITH NO BINDING OF SCREWS. TO BE DELIVERED WITH FOOTING ATTACHED.
  - ⑧ WARPAGE OF ITEMS 2, 3, & FOOTING TO BE MINIMIZED USING PREFERRED METHODS, IE. HEAT SINKING.

REV.	DATE	DCN #	DRAWING TREE #
v1	05 AUGUST 2010	E1000182-v1	-
-	-	-	-
-	-	-	-

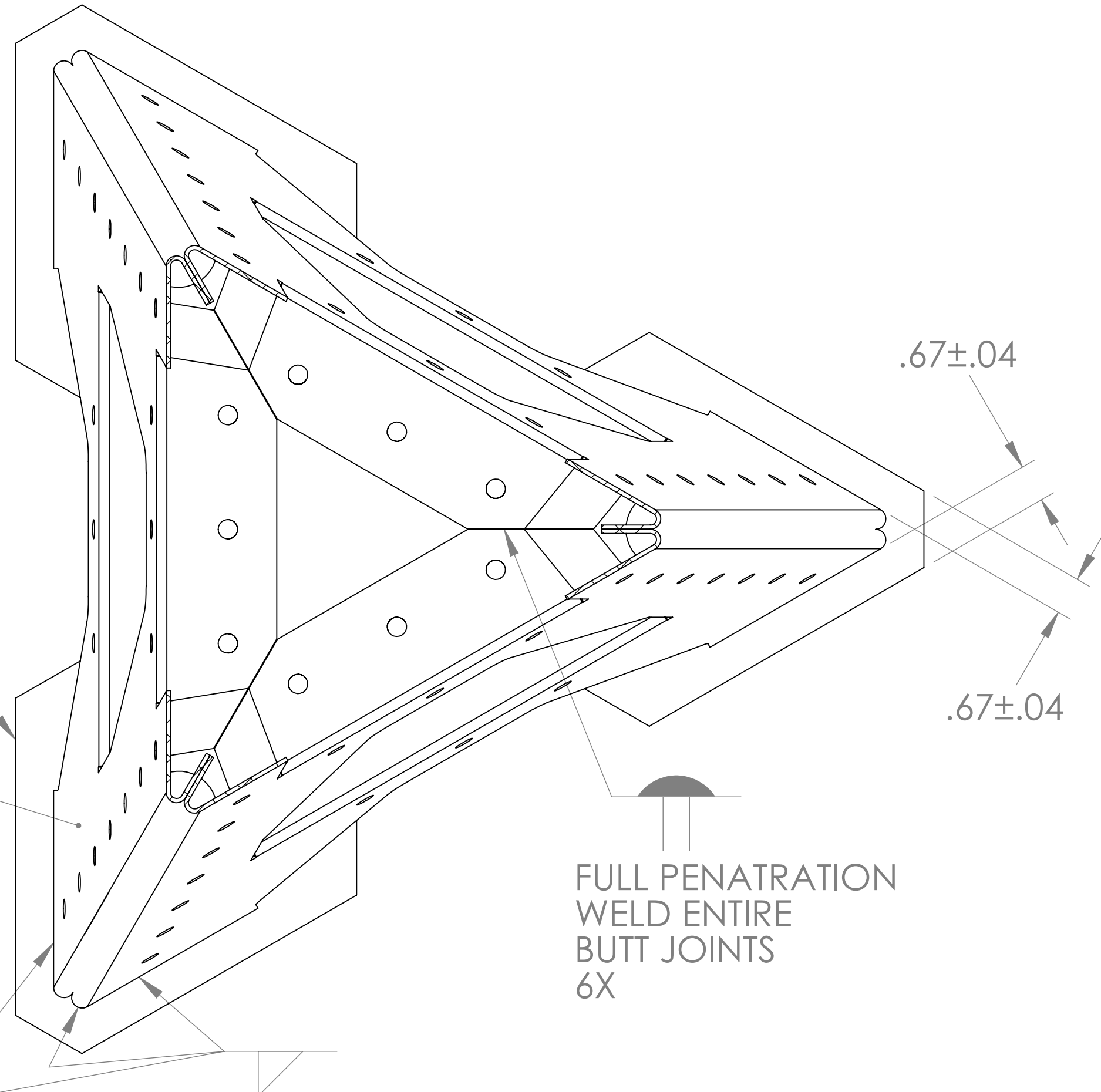

FILLET WELD ALL ITEM 1 / ITEM 2 INTERFACES (OUTSIDE ONLY) ALL THREE LOCATIONS

SECTION A-A

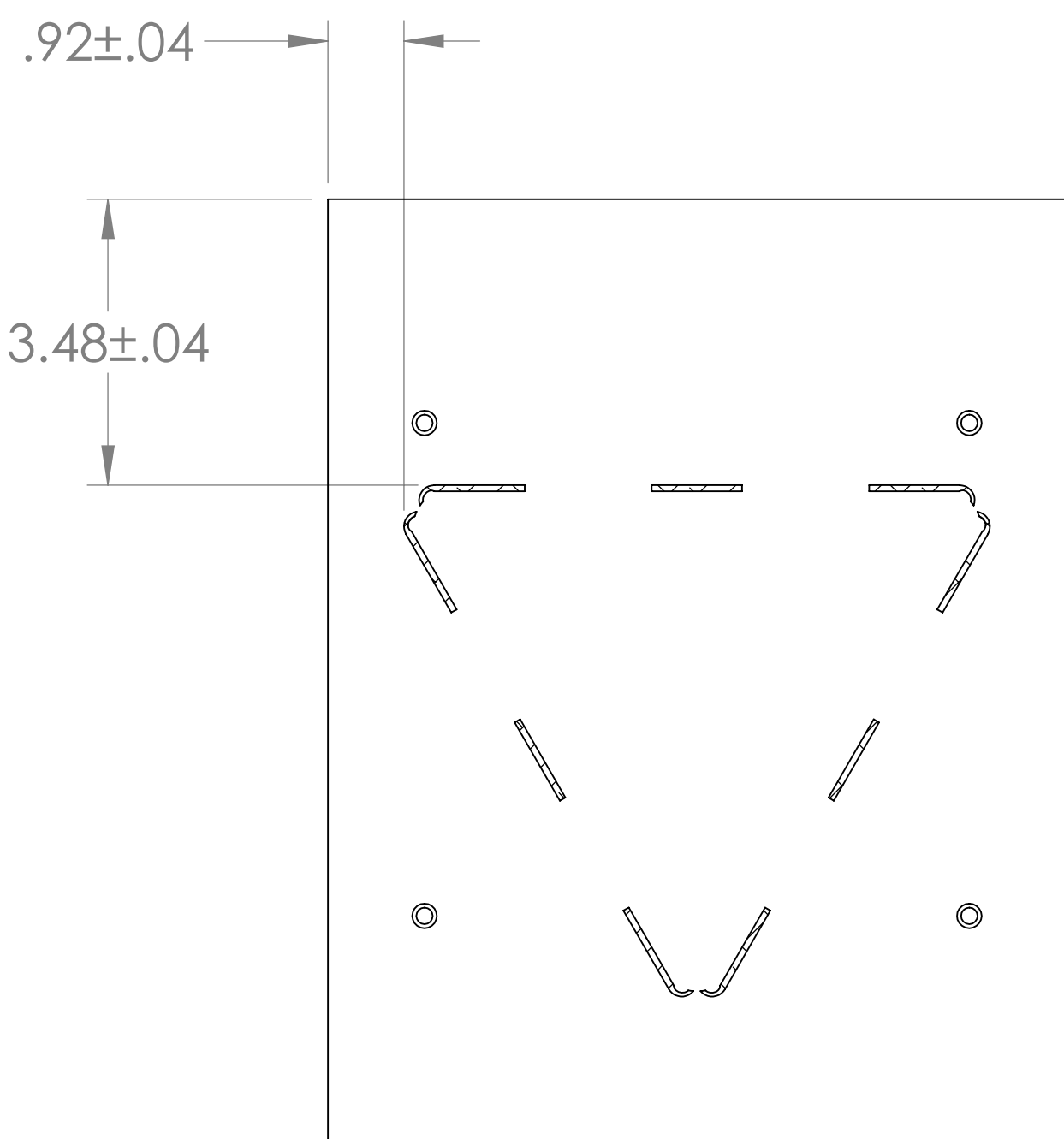

SECTION B-B  
SCALE 1 : 2

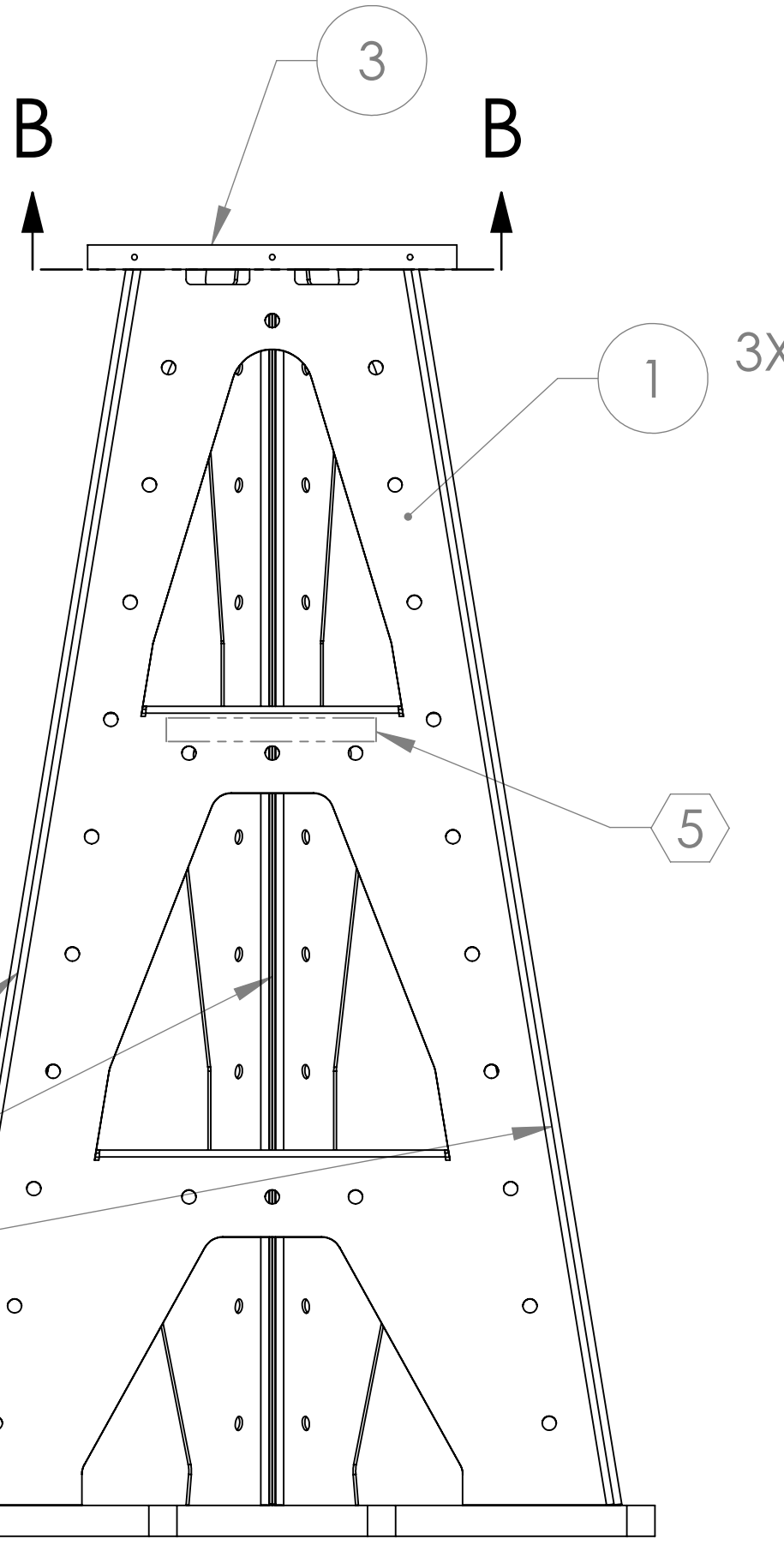
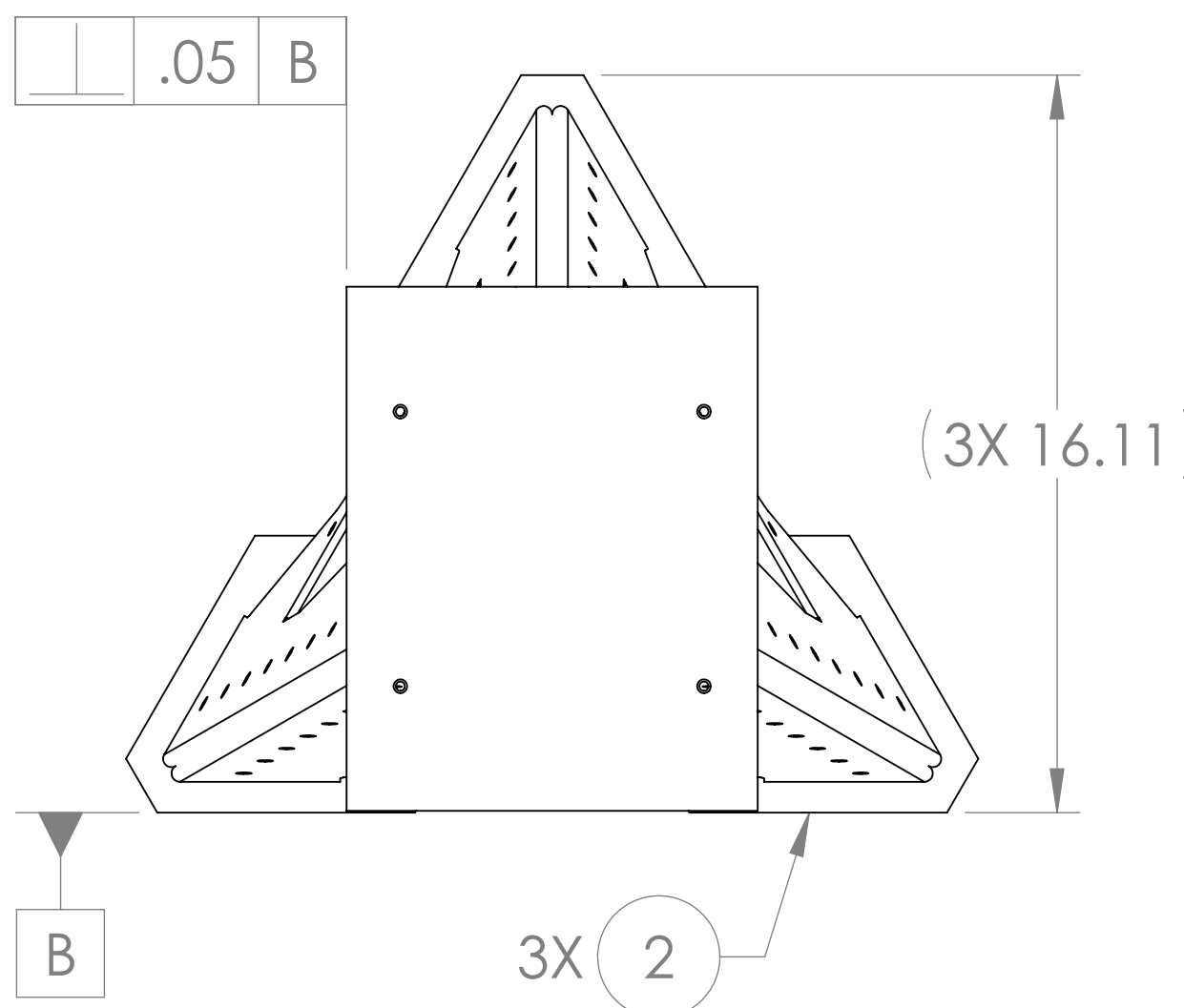

1-2  
3/8-2  
3 VERTICAL SEAMS. INTERNAL & EXTERNAL INCLUDE ENDS

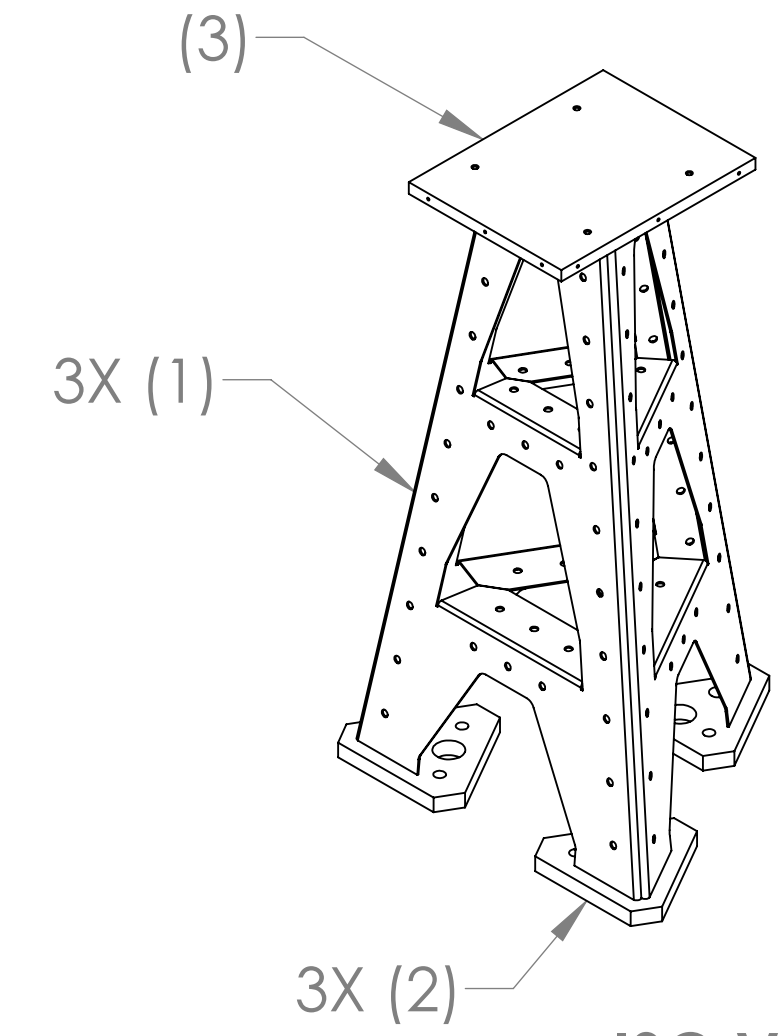

ISO VIEW

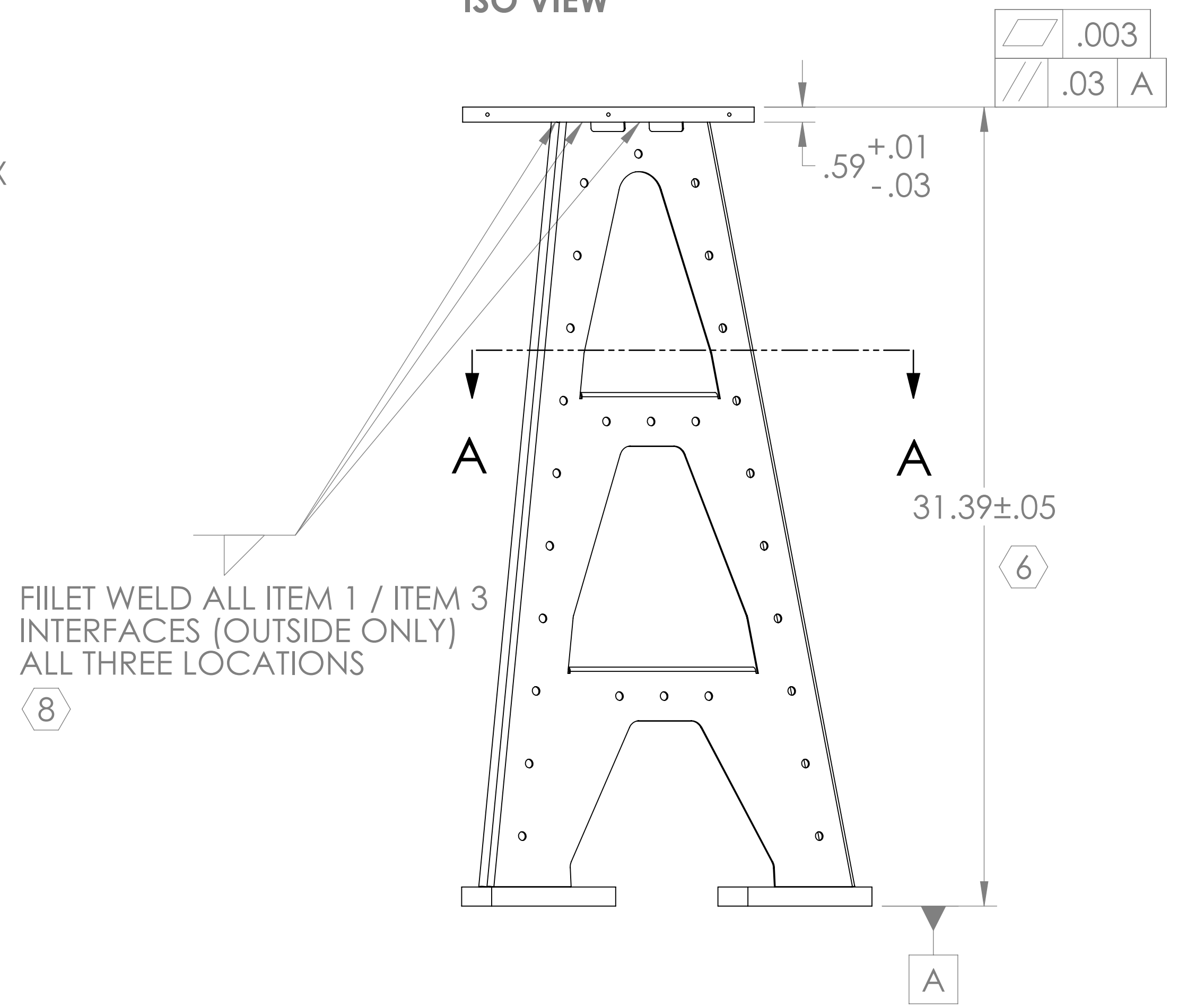

FILLET WELD ALL ITEM 1 / ITEM 3 INTERFACES (OUTSIDE ONLY) ALL THREE LOCATIONS

NOTES AND TOLERANCES: (UNLESS OTHERWISE SPECIFIED)	
DIMENSIONS ARE IN INCHES	
TOLERANCES: .XX ± N/A .XXX ± N/A	
ANGULAR ± N/A°	
MATERIAL	FINISH
N/A	N/A μinch

CALIFORNIA INSTITUTE OF TECHNOLOGY MASSACHUSETTS INSTITUTE OF TECHNOLOGY	
SYSTEM	SUB-SYSTEM
ADVANCED LIGO	AOS
NEXT ASSY	D1001851

ITEM NO.	PART NUMBER	DESCRIPTION	MATERIAL	Q/LL	O/RE	SPARE	TOTAL
3	D1001611-1	ALIGO AOS OPLEV TRX PIER TABLE (HAM)	304 SSSL	1			0
2	D1000426	ALIGO AOS PIER BASE 1	304 SSSL	3			0
1	D1001853	ALIGO AOS OPLEV TRX PIER SIDE PANEL (HAM-LLO)	304 SSSL	3			0

PART NAME		DESIGNER		DATE		SIZE		DWG. NO.		REV.	
ALIGO AOS OPLEV TRX PIER WELDMENT (HAM)		C. CONLEY		5 AUG 2010		D		D1001854		v1	
		DRAFTER		09 AUG 2010							
		CHECKER									
		APPROVAL									

SCALE: 1:4 PROJECTION: SHEET 1 OF 1

NOTES CONTINUED:  
 (1) STOCK FINISH / AS RECEIVED.

REV.	DATE	DCN #	DRAWING TREE #
v1	06 AUGUST 2010	E1000182-v1	-
-	-	-	-
-	-	-	-

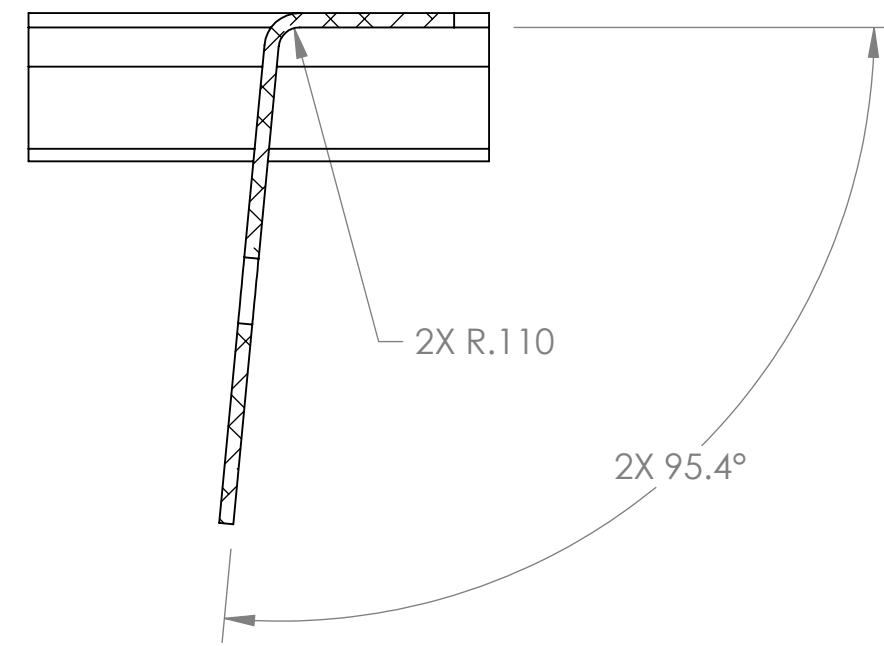

SECTION A-A  
SCALE 1 : 1

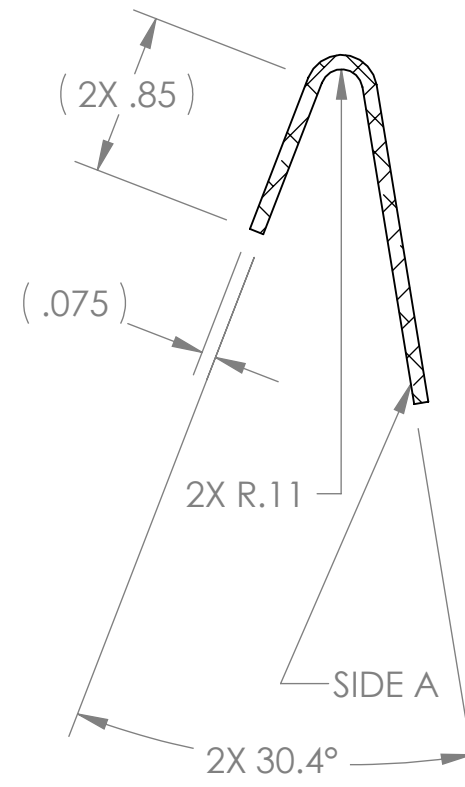

SECTION B-B  
SCALE 1 : 1

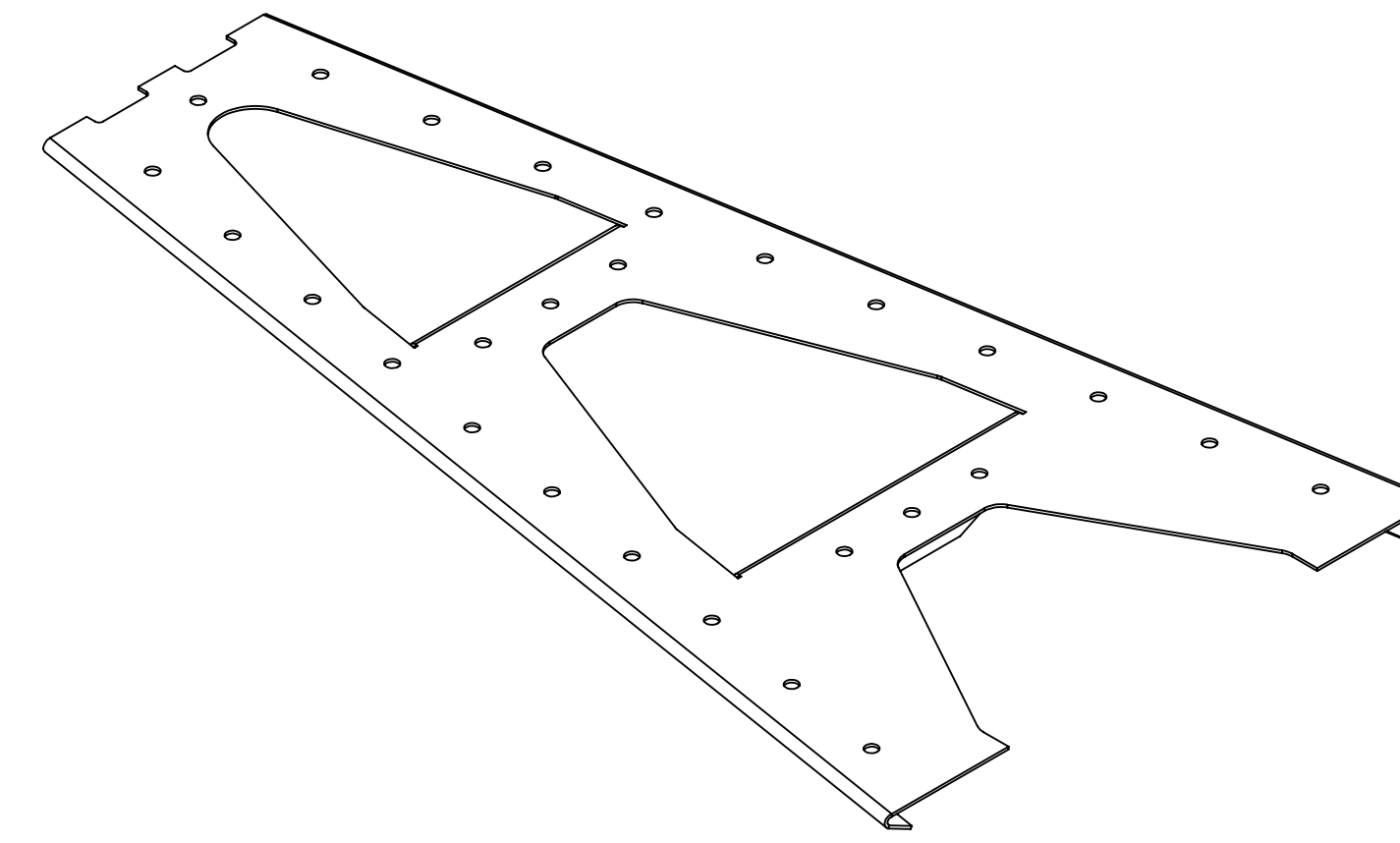

ISO VIEW

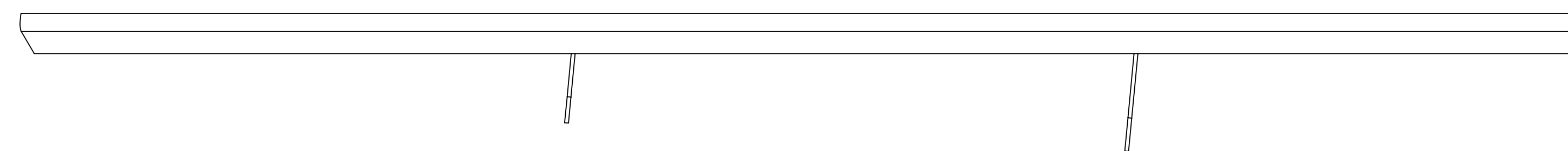
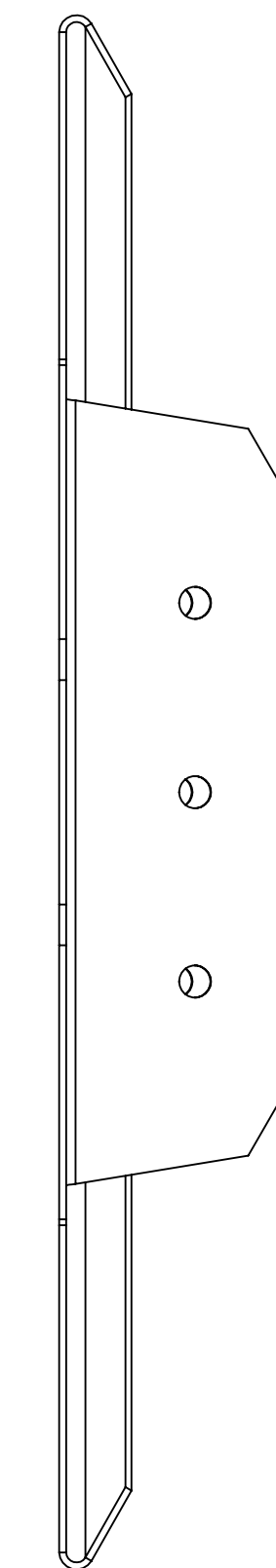
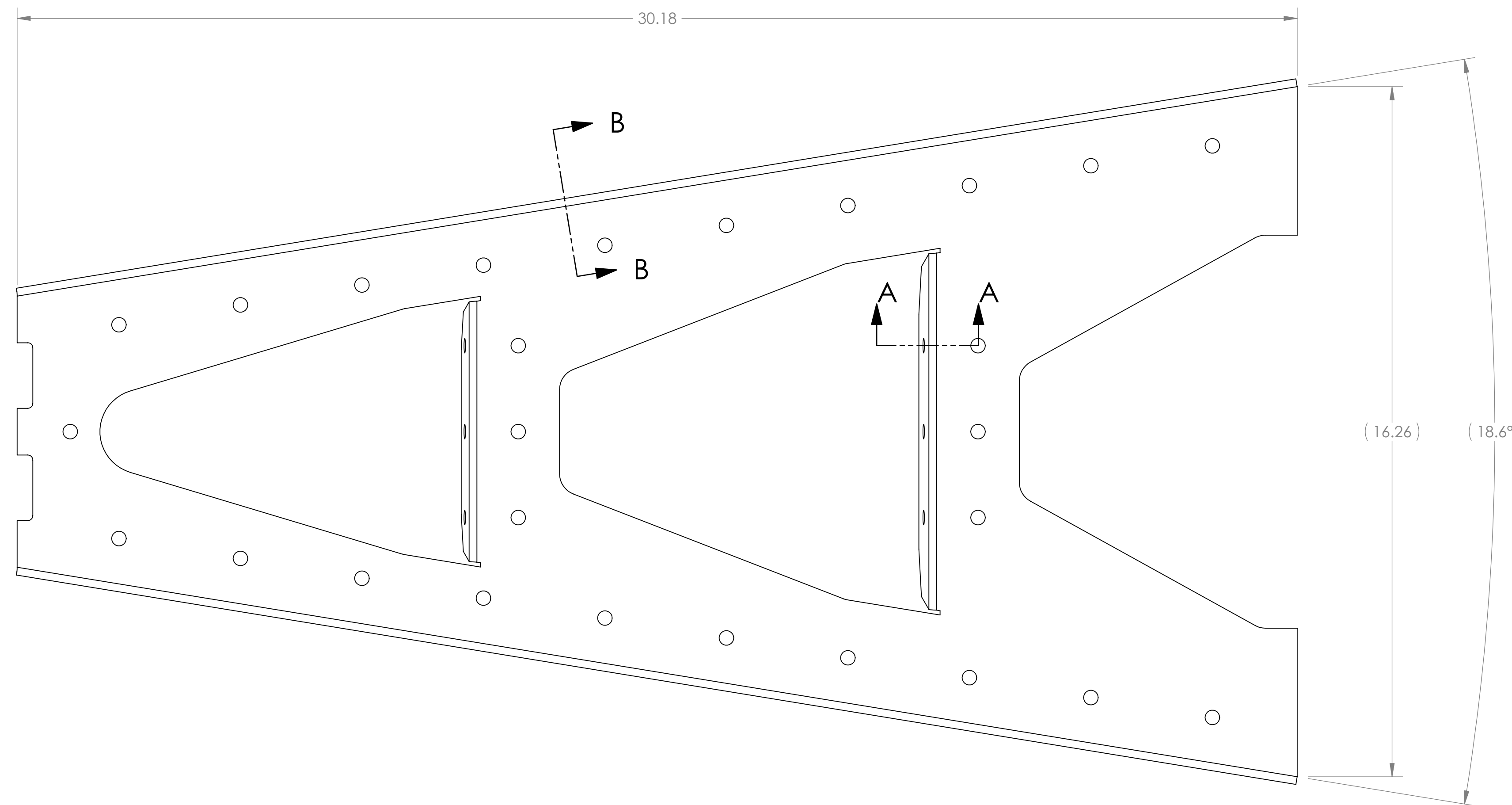
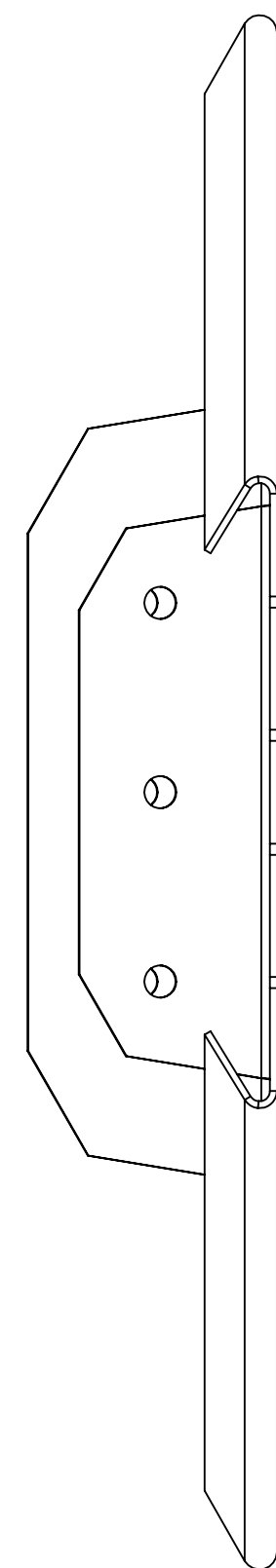

DIMENSIONS ARE IN INCHES		NOTES AND TOLERANCES: (UNLESS OTHERWISE SPECIFIED)		LIGO CALIFORNIA INSTITUTE OF TECHNOLOGY MASSACHUSETTS INSTITUTE OF TECHNOLOGY		PART NAME	
TOLERANCES: .XX ± .01 .XXX ± .005		1. INTERPRET DRAWING PER ASME Y14.5-1994. 2. REMOVE ALL SHARP EDGES, R.02 MIN. 3. DO NOT SCALE FROM DRAWING. 4. ALL MACHINING FLUIDS MUST BE FULLY SYNTHETIC, FULLY WATER SOLUBLE AND FREE OF SULFUR, SILICONE, AND CHLORINE.		ADVANCED LIGO		ALIGO AOS	
ANGULAR ± 1.0°		MATERIAL: 304 SSSL SHEET, 14 GAUGE		NEXT ASSY: D1001854		OPLEV TRX PIER SIDE PANEL (HAM)	
		FINISH: (1)		DESIGNER: C. CONLEY		SCALE: 1:2	
				DRAFTER: N. KILPATRICK		PROJECTION:	
				CHECKER:		DWG. NO. D1001853	
				APPROVAL:		REV. v1	
						SHEET 1 OF 2	

D1001853.dwg: AOS: Oplev TRX Pier Side Panel (HAM).LLO: PART PDM REV: X-000: DRAWING PDM REV: X-005

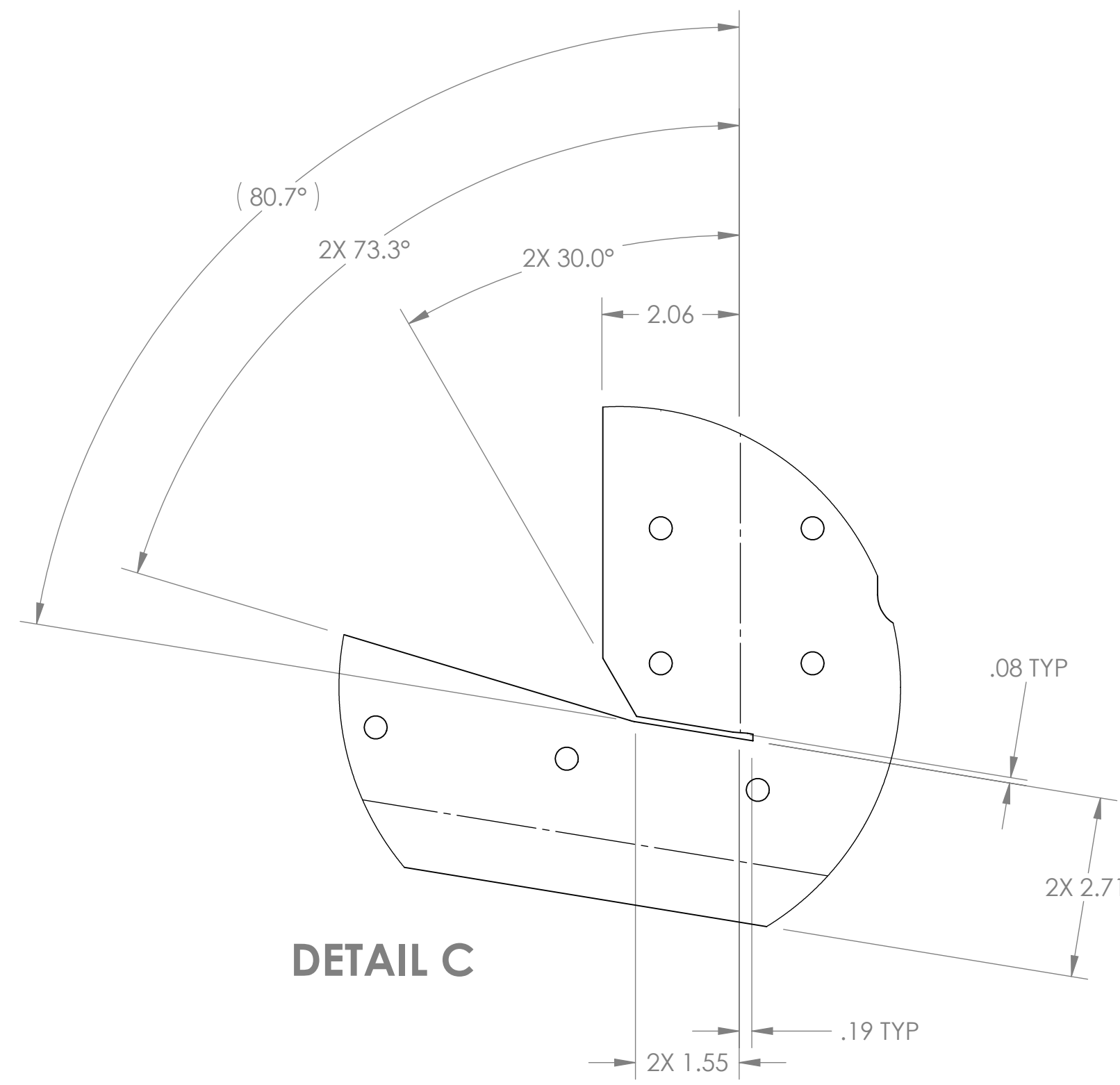

**DETAIL C**

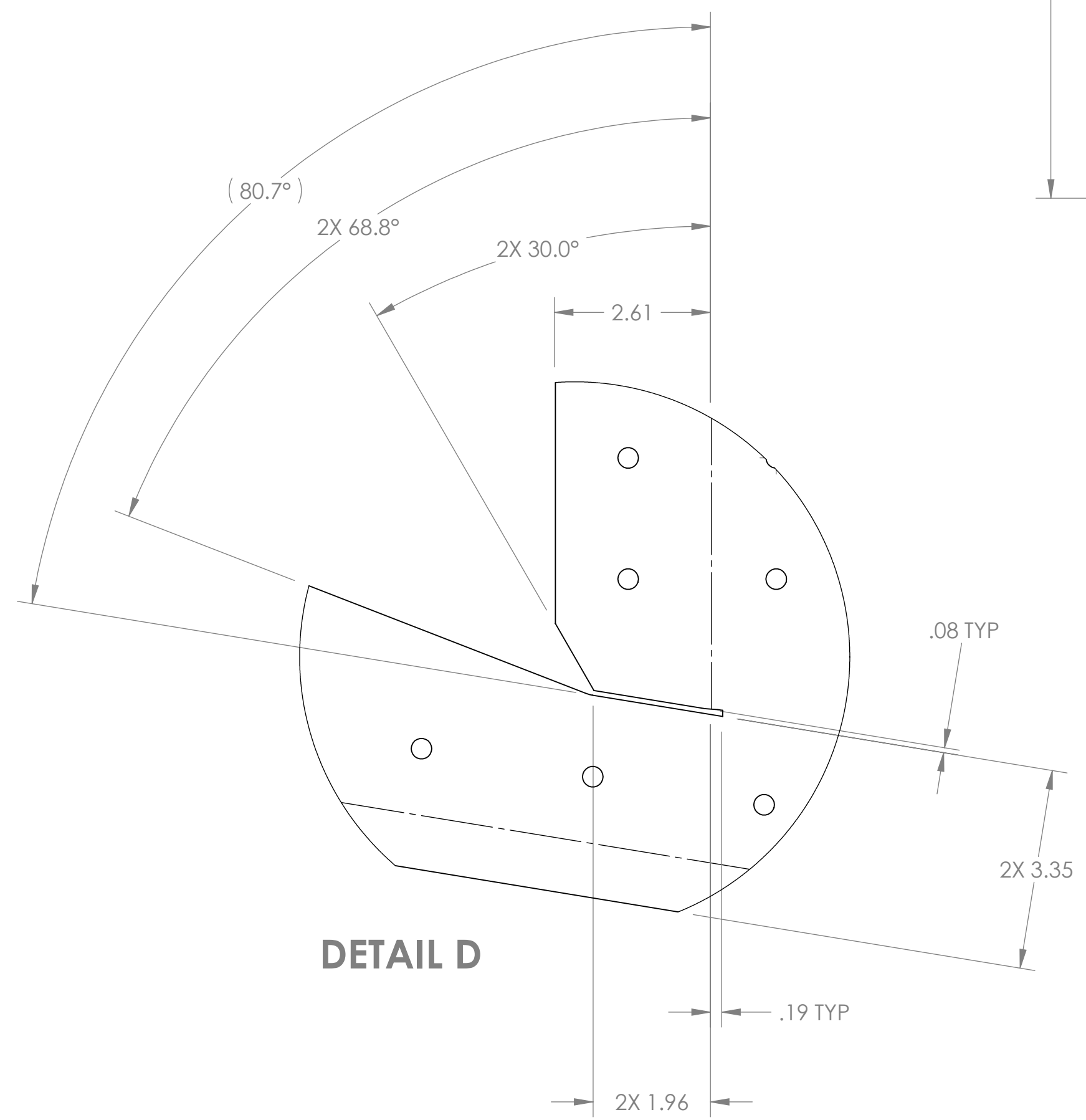

**DETAIL D**

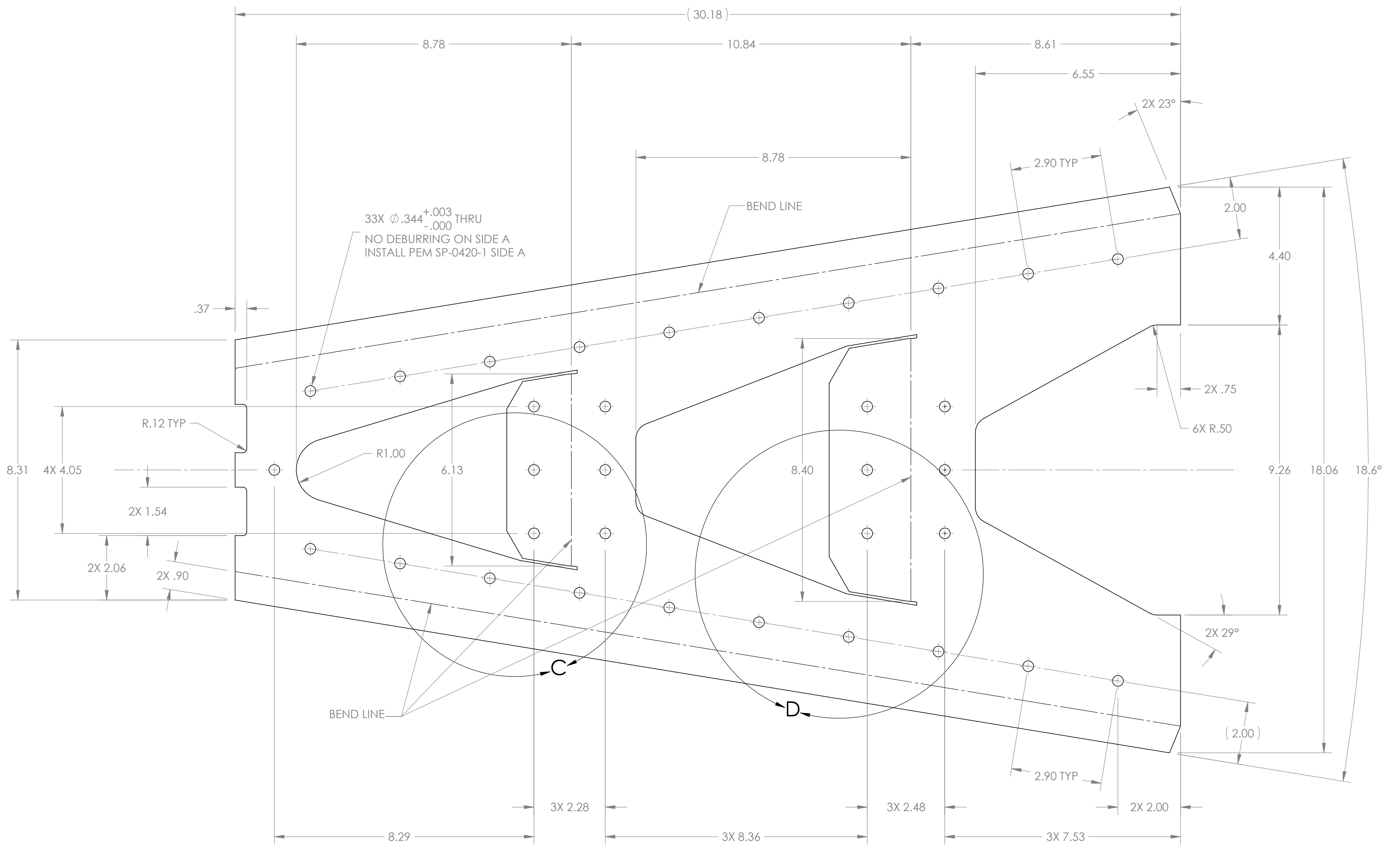

**FLAT PATTERN**

<b>LIGO</b> CALIFORNIA INSTITUTE OF TECHNOLOGY MASSACHUSETTS INSTITUTE OF TECHNOLOGY	
SIZE DWG. NO.	REV.
<b>D</b> <b>D1001853</b>	<b>v1</b>
SCALE: 1:2	PROJECTION:
SHEET 2 OF 2	

D:\001853.dwg ACS Oct 16 11:58 AM TRX File Side Panel (HAM.LLO) PART PDM REV: X-000 DRAWING PDM REV: X-005



NOTES CONTINUED:  
 5. SCRIBE, ENGRAVE, OR MECHANICALLY STAMP (NO INKS OR DYES) DRAWING PART NUMBER, REVISION (AND VARIANT OR TYPE IF APPLICABLE) ON NOTED SURFACE OF PART FOLLOWED ON THE NEXT LINE WITH A THREE DIGIT SERIAL NUMBER. SERIAL NUMBERS START AT 001 FOR THE FIRST ARTICLE AND PROCEED CONSECUTIVELY. USE MINIMUM 0.12" HIGH CHARACTERS, UNLESS THE SIZE OF THE PART DICTATES SMALLER CHARACTERS. A VIBRATORY TOOL MAY BE USED. EXAMPLE: DXXXXXX-VY, TYPE-XX, S/N XXX

6. RAPID CUTTING METHOD ACCEPTABLE FOR OUTER PROFILE AND Ø 4.00 HOLES.

REV.	DATE	DCN #	DRAWING TREE #
v1	28 MAY 2010	E1000182-v1	-
v2	15 OCT 2010	E1000182-v2	-
-	-	-	-

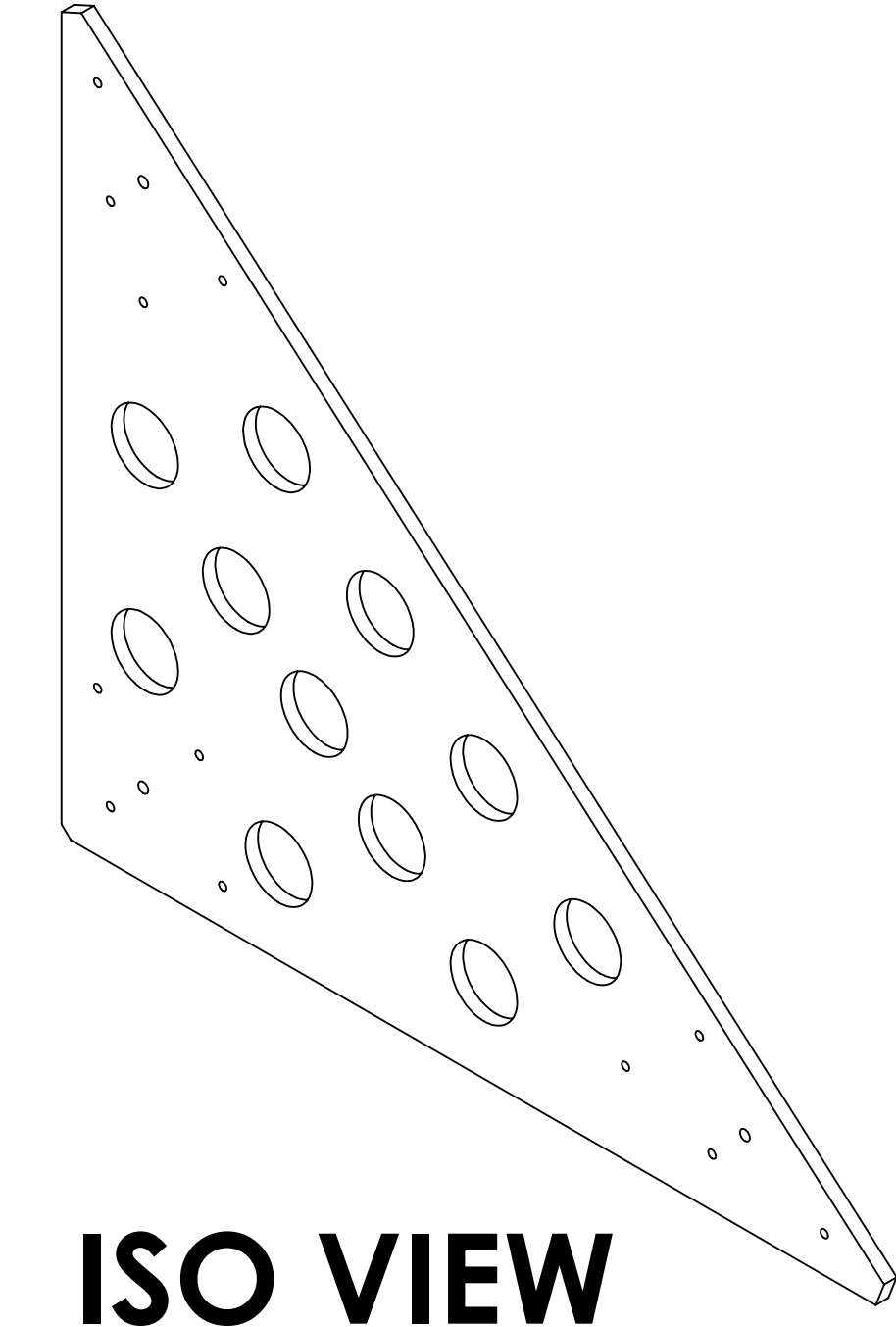
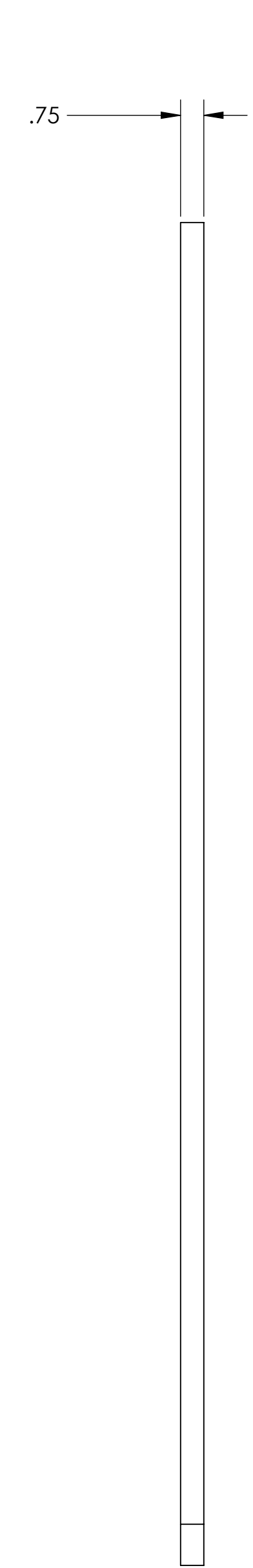
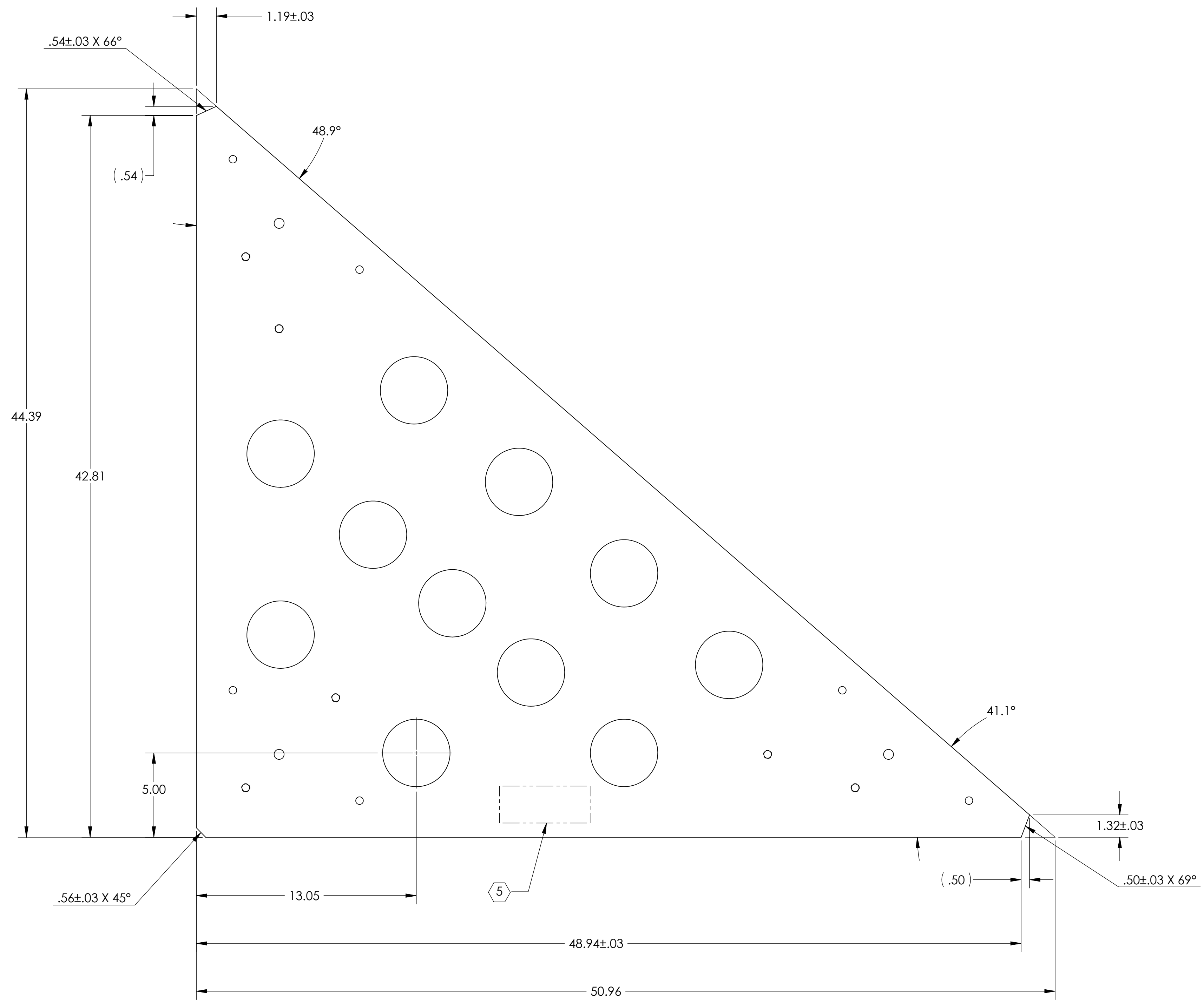

**ISO VIEW**

DIMENSIONS ARE IN INCHES		NOTES AND TOLERANCES: (UNLESS OTHERWISE SPECIFIED)		CALIFORNIA INSTITUTE OF TECHNOLOGY MASSACHUSETTS INSTITUTE OF TECHNOLOGY		PART NAME		ALIGO AOS PIER FOOTING 4	
TOLERANCES: .XX ± .01 .XXX ± .005		1. INTERPRET DRAWING PER ASME Y14.5-1994. 2. REMOVE ALL SHARP EDGES, R.02 MIN. 3. DO NOT SCALE FROM DRAWING. 4. ALL MACHINING FLUIDS MUST BE FULLY SYNTHETIC, FULLY WATER SOLUBLE AND FREE OF SULFUR, SILICONE, AND CHLORINE.		SYSTEM		DESIGNER		C. CONLEY 06 APR 2010	
ANGULAR ± 1.0°		MATERIAL		SUB-SYSTEM		DRAFTER		N. KILPATRICK 28 MAY 2010	
		302 SSSL		AOS		CHECKER		D	
		FINISH		NEXT ASSY		APPROVAL		D1000311	
		63 μinch		D1000311		SCALE: 1:4		PROJECTION:	
						SHEET 1 OF 3		REV. v2	

D1000836.dwg:ALIGO AOS Pier Footing 4, PART PDM REV: X-229, DRAWING PDM REV: X-025



8 7 6 5 4 3 2 1

H  
G  
F  
E  
D  
C  
A

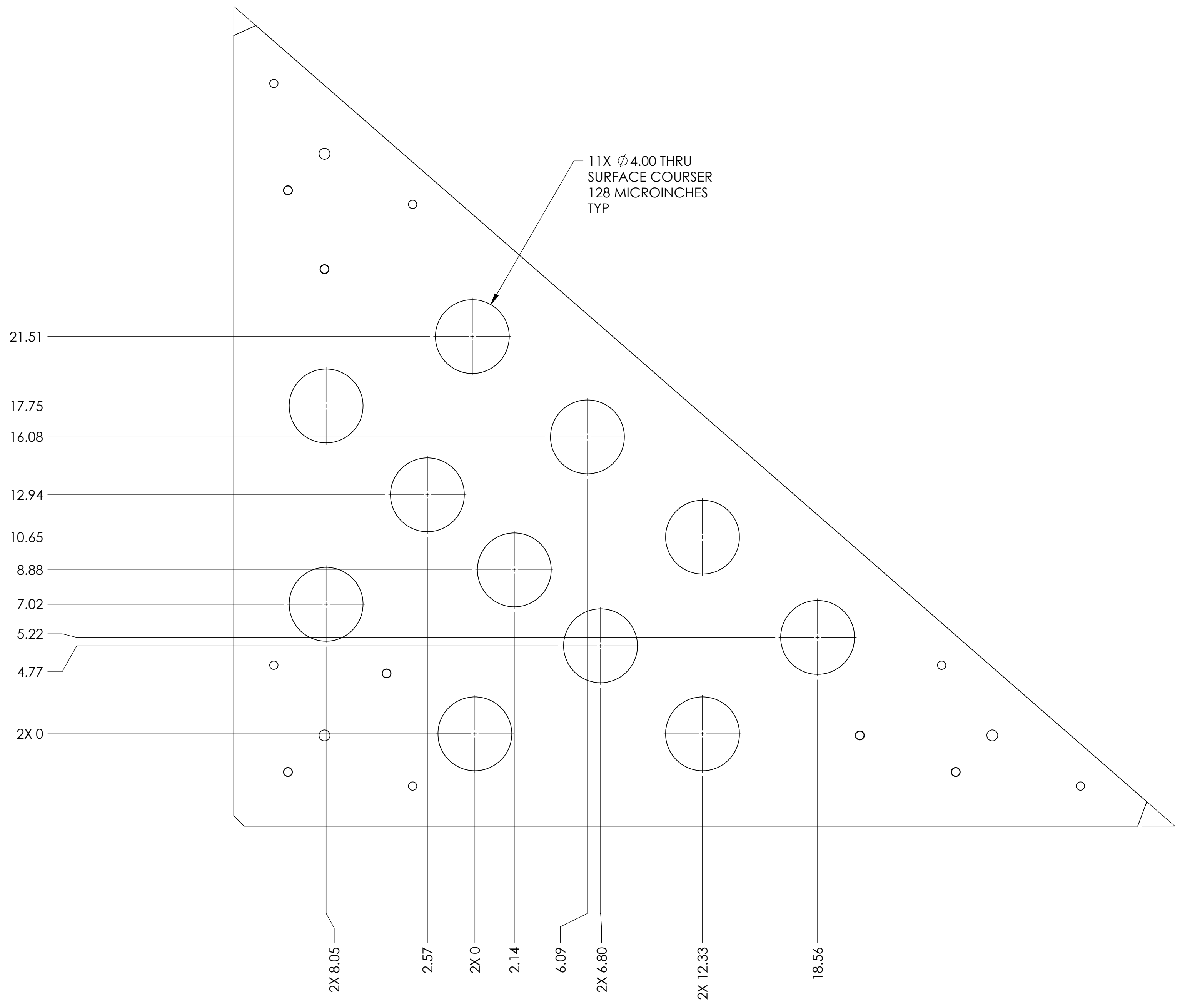

**LIGO** CALIFORNIA INSTITUTE OF TECHNOLOGY  
MASSACHUSETTS INSTITUTE OF TECHNOLOGY

SIZE	DWG. NO.	REV.
D	D1000836	v2
SCALE: 1:4	PROJECTION:	SHEET 2 OF 3

D:\000836\ligo\ACS\Ref\Footing 4.PART.PDM\REV.X-229.DRAWING.PDM\REV.X-025

8 7 6 5 4 3 2 1

H  
G  
F  
E  
D  
C  
B  
A

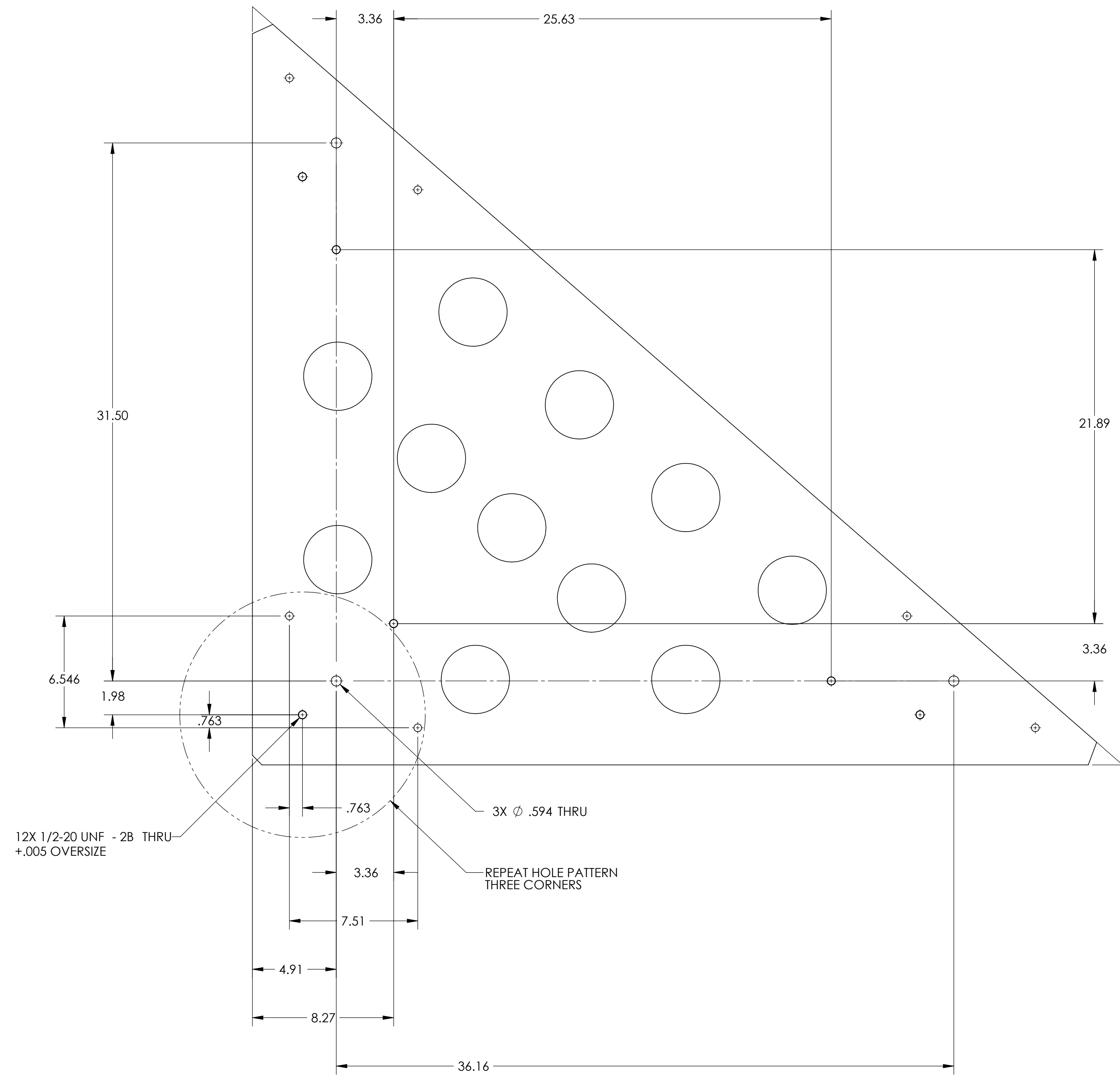

**LIGO** CALIFORNIA INSTITUTE OF TECHNOLOGY  
MASSACHUSETTS INSTITUTE OF TECHNOLOGY

SIZE	DWG. NO.	REV.
D	D1000836	v2
SCALE: 1:4	PROJECTION:	SHEET 3 OF 3

D:\000836\ligo\ACS\Part\Drawing 4.PART.PDM\REV.X-229.DRAWING.PDM.REV.X-025

8 7 6 5 4 3 2 1

D1000502 aLIGO AOS Oplev TX Height Tube, PART PDM REV: X-043, DRAWING PDM REV: X-020

8 7 6 5 4 3 2 1

NOTES CONTINUED:  
⑤ SCRIBE, ENGRAVE, OR MECHANICALLY STAMP (NO INKS OR DYES) DRAWING PART NUMBER AND REVISION ON NOTED SURFACE FOLLOWED ON THE NEXT LINE BY A THREE DIGIT SERIAL NUMBER. SERIAL NUMBERS START AT 001 FOR THE FIRST ARTICLE AND PROCEED CONSECUTIVELY. USE .07" HIGH CHARACTERS. EXAMPLE: DXXXXXX-VY, S/N 001. A VIBRATORY TOOL MAY BE USED.

REV.	DATE	DCN #	DRAWING TREE #
v1	03 JUN 2010	E1000182-v1	-
v2	26 AUG 2010	E1000168	-
v3	24 NOV 2010	E1000182-v2	-

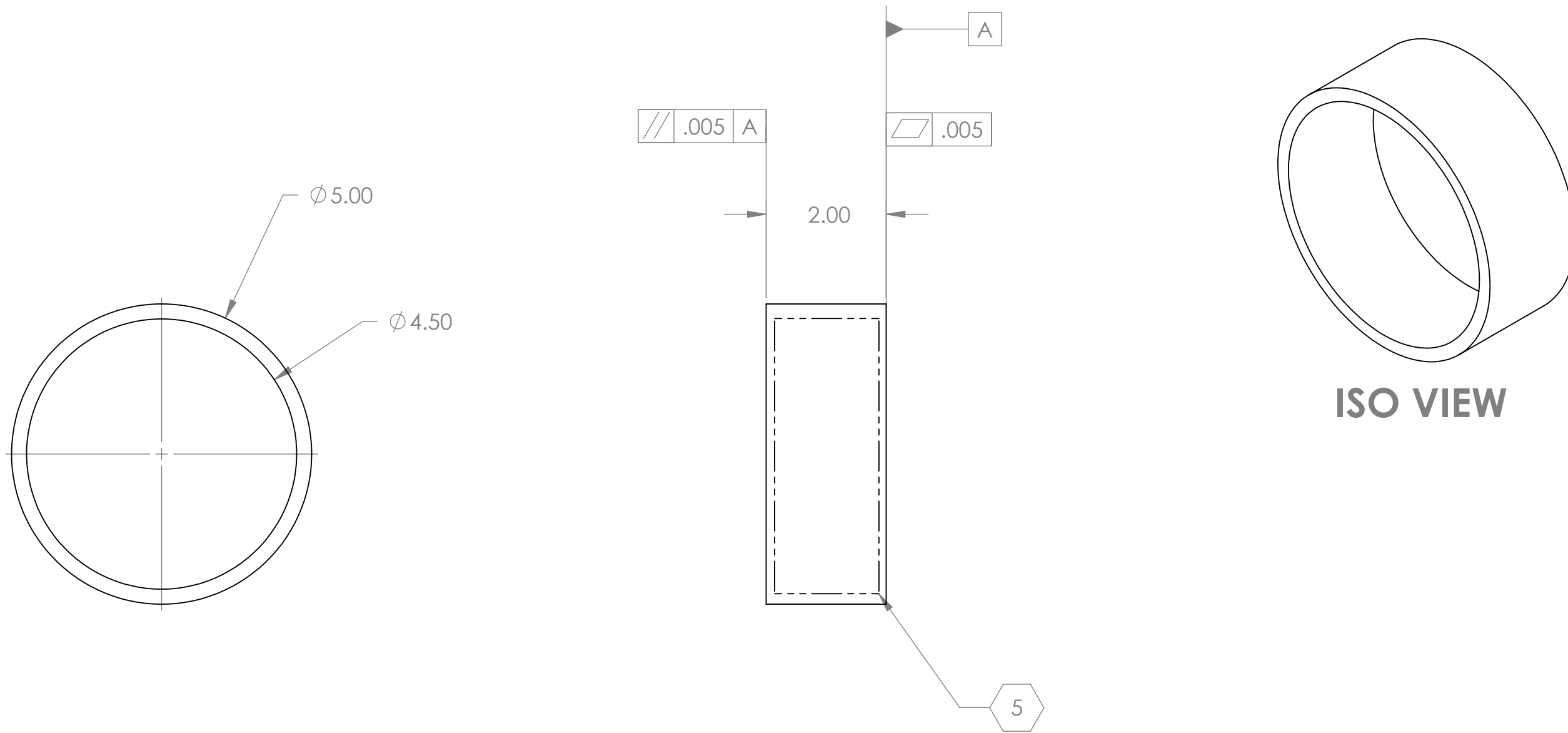

- 8. MACHINEALL SURFACES TO REMOVE OXCIDES AN MILL FINISH, USE OF ABRASIVE TECHNIQUES IS NOT ALLOWED.
- 7. DO NOT USE SANDPAPER, SCOTCH BRITE OR SIMILAR PRODUCTS.
- 6. ALL PARTS SHALL BE MANUFACTURED IN ACCORDANCE WITH LIGO SPECIFICATION E0900363.

NOTES AND TOLERANCES: (UNLESS OTHERWISE SPECIFIED)	
DIMENSIONS ARE IN INCHES	
TOLERANCES: .XX ± .01 .XXX ± .005 ANGULAR ± 1.0°	
1. INTERPRET DRAWING PER ASME Y14.5-1994. 2. REMOVE ALL SHARP EDGES, R.02 MIN. 3. DO NOT SCALE FROM DRAWING. 4. ALL MACHINING FLUIDS MUST BE FULLY SYNTHETIC, FULLY WATER SOLUBLE AND FREE OF SULFUR, SILICONE, AND CHLORINE.	
MATERIAL	FINISH
6061-T6 Al	63 μinch

CALIFORNIA INSTITUTE OF TECHNOLOGY MASSACHUSETTS INSTITUTE OF TECHNOLOGY		PART NAME		ALIGO AOS	
SYSTEM		SUB-SYSTEM		OPLEV PIER TX HEIGHT TUBE	
ADVANCED LIGO		AOS		DESIGNER	C. CONLEY 05 MAR 2010
NEXT ASSY		D1000308		DRAFTER	N. KILPATRICK 3 JUNE 2010
				CHECKER	
				APPROVAL	
				SIZE	DWG. NO.
				B	D1000502
				SCALE:	1:1
				PROJECTION:	
				SHEET 1 OF 1	

8 7 6 5 4 3 2 1

NOTES CONTINUED:  
 ⑤ SCRIBE, ENGRAVE, OR MECHANICALLY STAMP (NO INKS OR DYES) DRAWING PART NUMBER, REVISION (AND VARIANT OR TYPE IF APPLICABLE) ON NOTED SURFACE OF PART FOLLOWED ON THE NEXT LINE WITH A THREE DIGIT SERIAL NUMBER. SERIAL NUMBERS START AT 001 FOR THE FIRST ARTICLE AND PROCEED CONSECUTIVELY. USE MINIMUM 0.12" HIGH CHARACTERS, UNLESS THE SIZE OF THE PART DICTATES SMALLER CHARACTERS. A VIBRATORY TOOL MAY BE USED. EXAMPLE: DXXXXXX-VY, TYPE-XX, S/N XXX

REV.	DATE	DCN #	DRAWING TREE #
v1	03 JUNE 2010	E1000182-V1	-
-	-	-	-
-	-	-	-

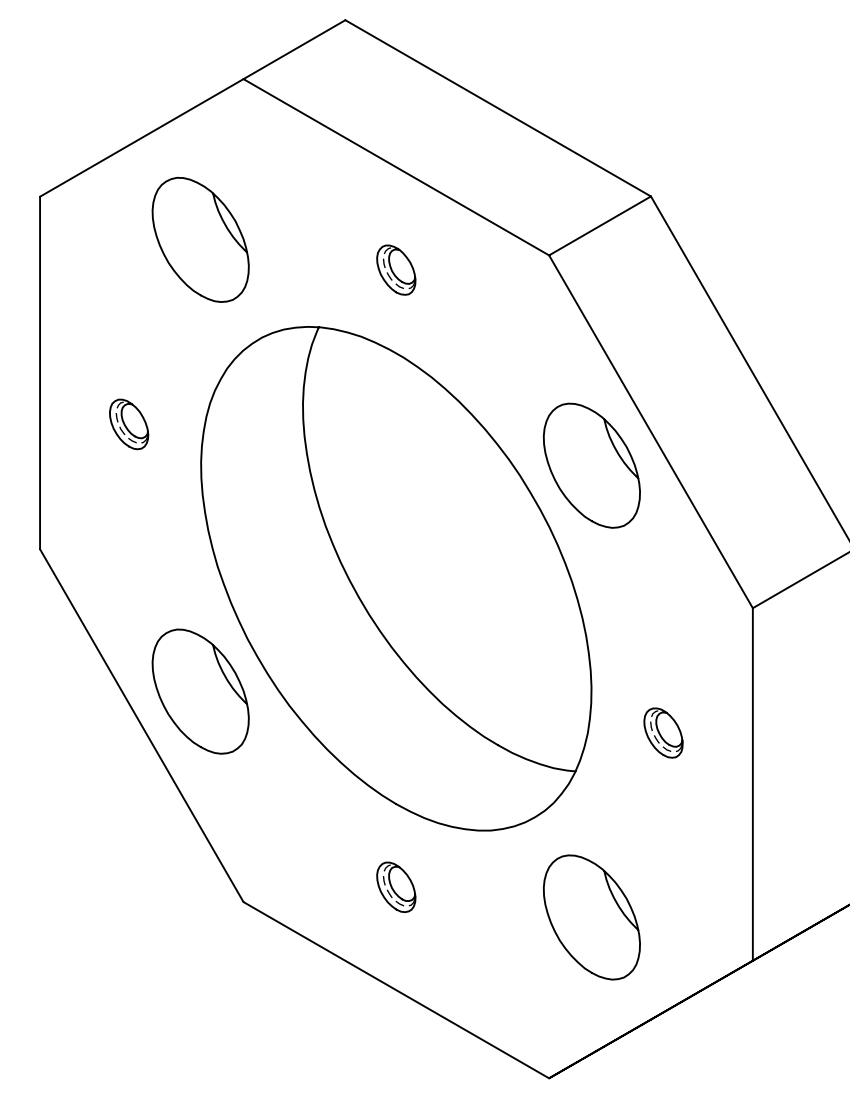

ISO VIEW

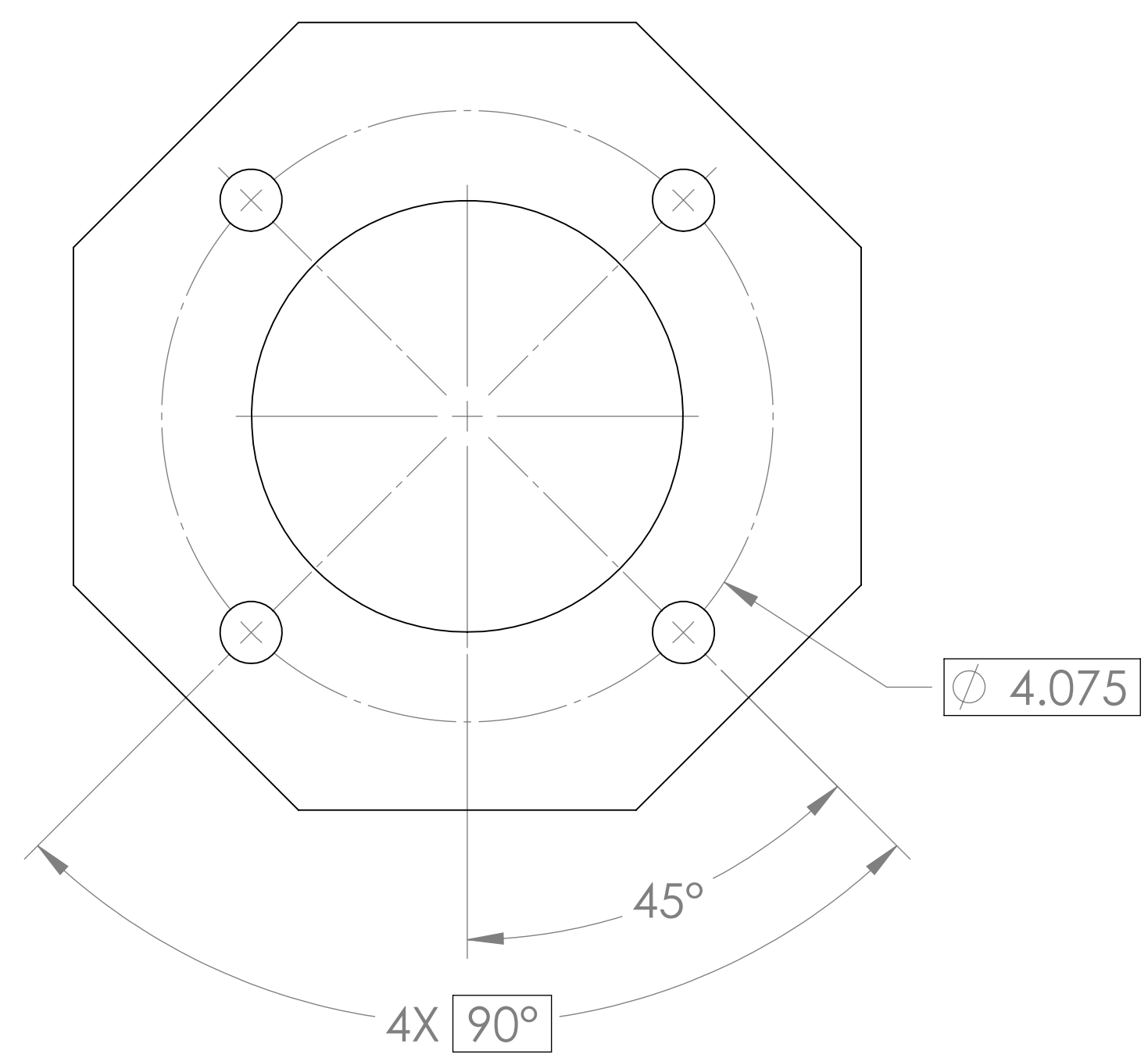
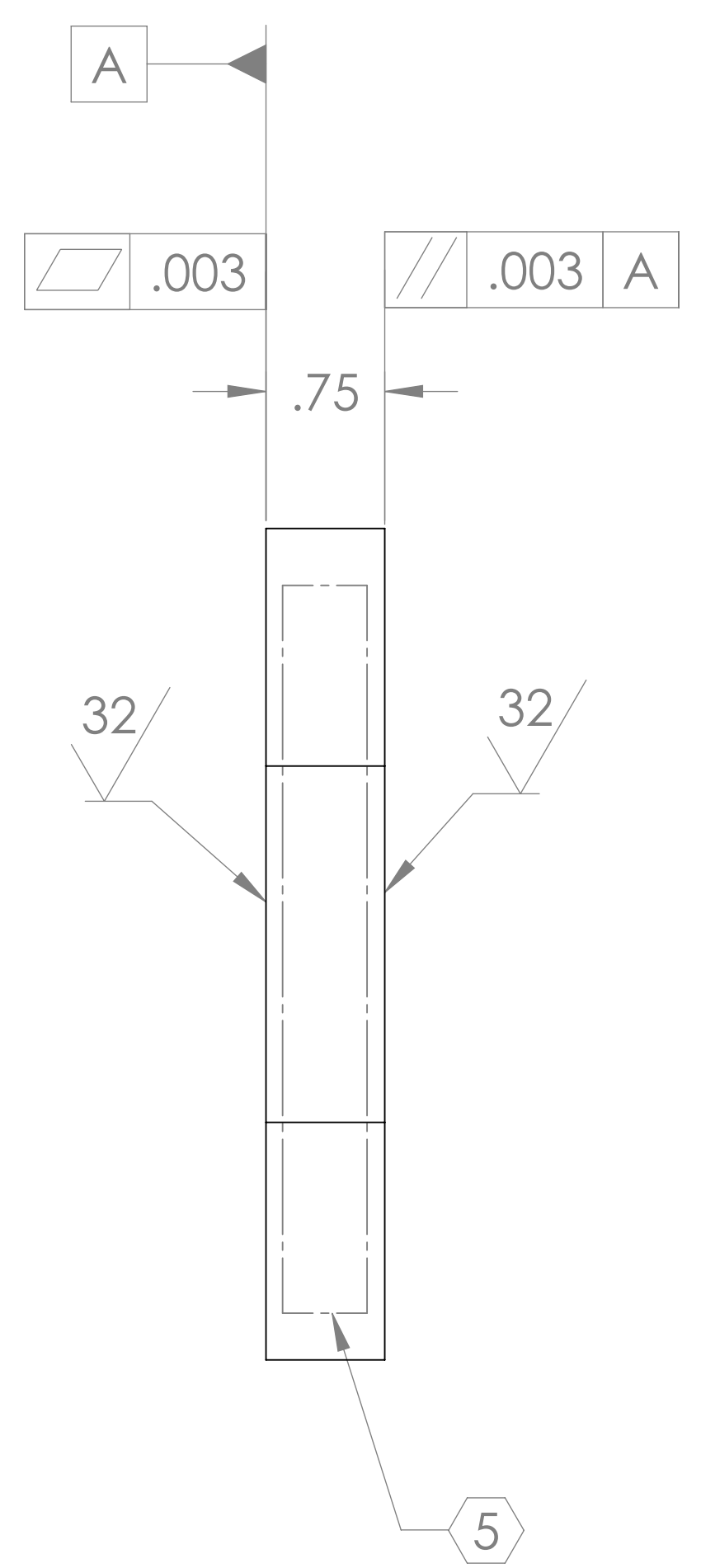
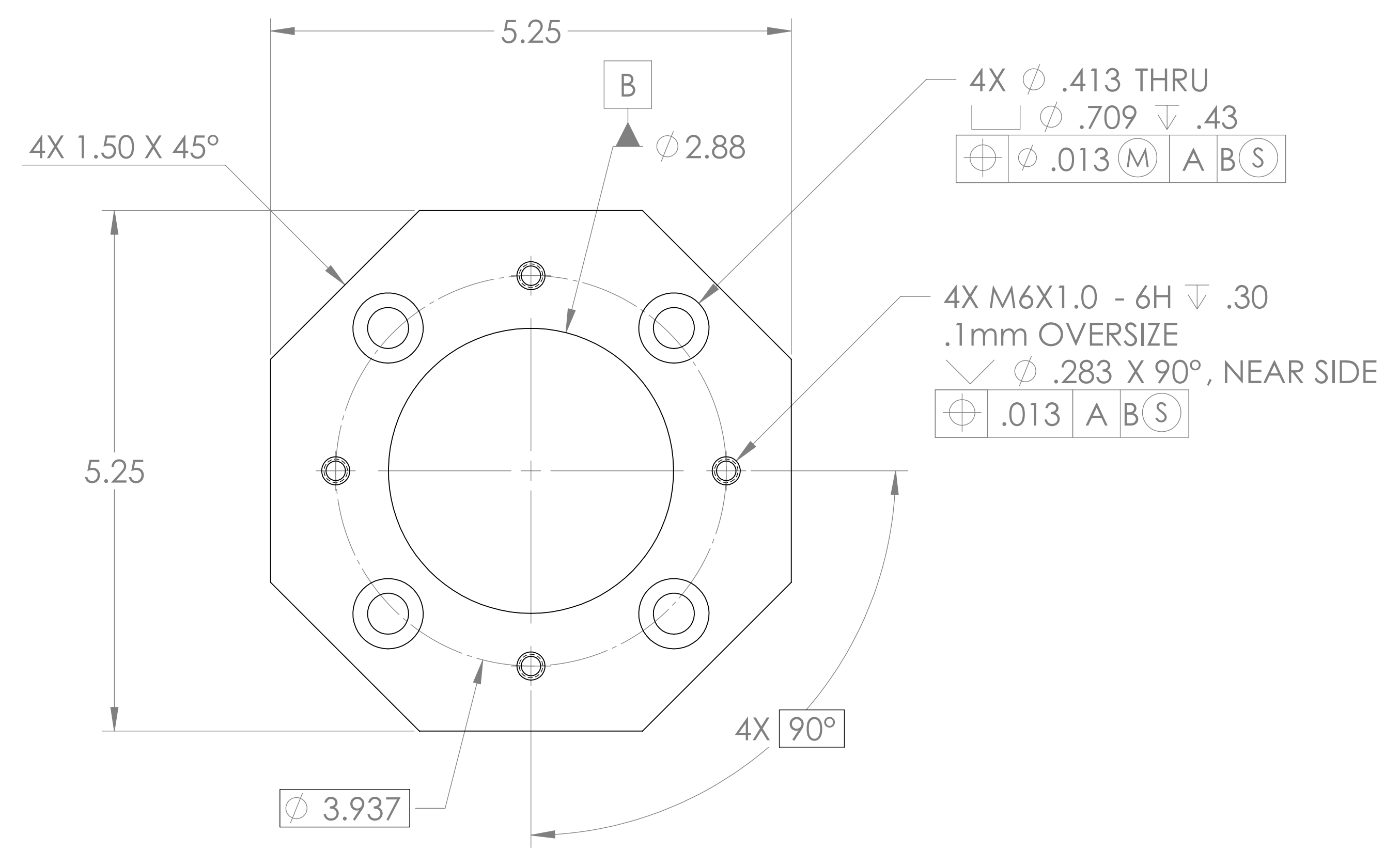

DIMENSIONS ARE IN INCHES		NOTES AND TOLERANCES: (UNLESS OTHERWISE SPECIFIED)		LIGO CALIFORNIA INSTITUTE OF TECHNOLOGY MASSACHUSETTS INSTITUTE OF TECHNOLOGY		PART NAME	
TOLERANCES: .XX ± .01 .XXX ± .005		1. INTERPRET DRAWING PER ASME Y14.5-1994. 2. REMOVE ALL SHARP EDGES, R.02 MIN. 3. DO NOT SCALE FROM DRAWING. 4. ALL MACHINING FLUIDS MUST BE FULLY SYNTHETIC, FULLY WATER SOLUBLE AND FREE OF SULFUR, SILICONE, AND CHLORINE.		SYSTEM ADVANCED LIGO		ALIGO AOS OPLEV TX MOUNTING PLATE	
ANGULAR ± 1.0°		MATERIAL 304 SSSL		SUB-SYSTEM AOS		DESIGNER C. CONLEY 05 MAR 2009	
		FINISH 63 μinch		NEXT ASSY D1000308		DRAFTER N. KILPATRICK 03 JUNE 2010	
						CHECKER	
						APPROVAL	
						SCALE: 1:1 PROJECTION:	
						SHEET 1 OF 1	

D1000509 ALIGO AOS Oplev TX Mounting Plate, PART PDM REV: X.021, DRAWING PDM REV: X.022

NOTES CONTINUED:  
 ⑤ SCRIBE, ENGRAVE, OR MECHANICALLY STAMP (NO INKS OR DYES) DRAWING PART NUMBER, REVISION (AND VARIANT OR TYPE IF APPLICABLE) ON NOTED SURFACE OF PART FOLLOWED ON THE NEXT LINE WITH A THREE DIGIT SERIAL NUMBER. SERIAL NUMBERS START AT 001 FOR THE FIRST ARTICLE AND PROCEED CONSECUTIVELY. USE MINIMUM 0.12" HIGH CHARACTERS, UNLESS THE SIZE OF THE PART DICTATES SMALLER CHARACTERS. A VIBRATORY TOOL MAY BE USED. EXAMPLE: DXXXXXX-VY, TYPE-XX, S/N XXX

REV.	DATE	DCN #	DRAWING TREE #
v1	03 JUNE 2010	E1000182-V1	-
-	-	-	-
-	-	-	-

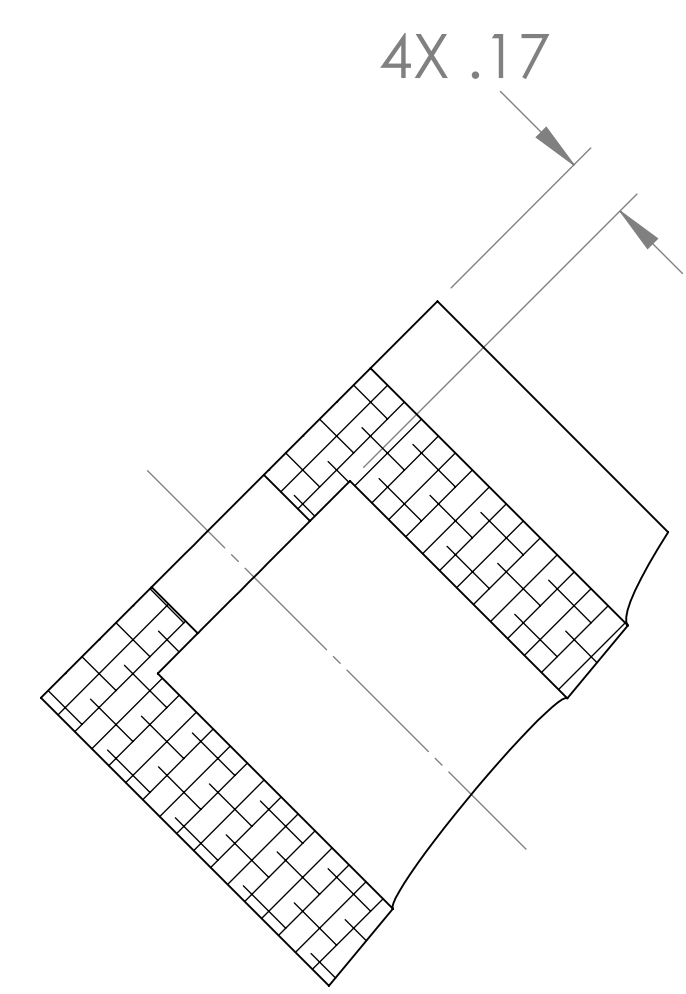

SECTION B-B  
SCALE 2:1

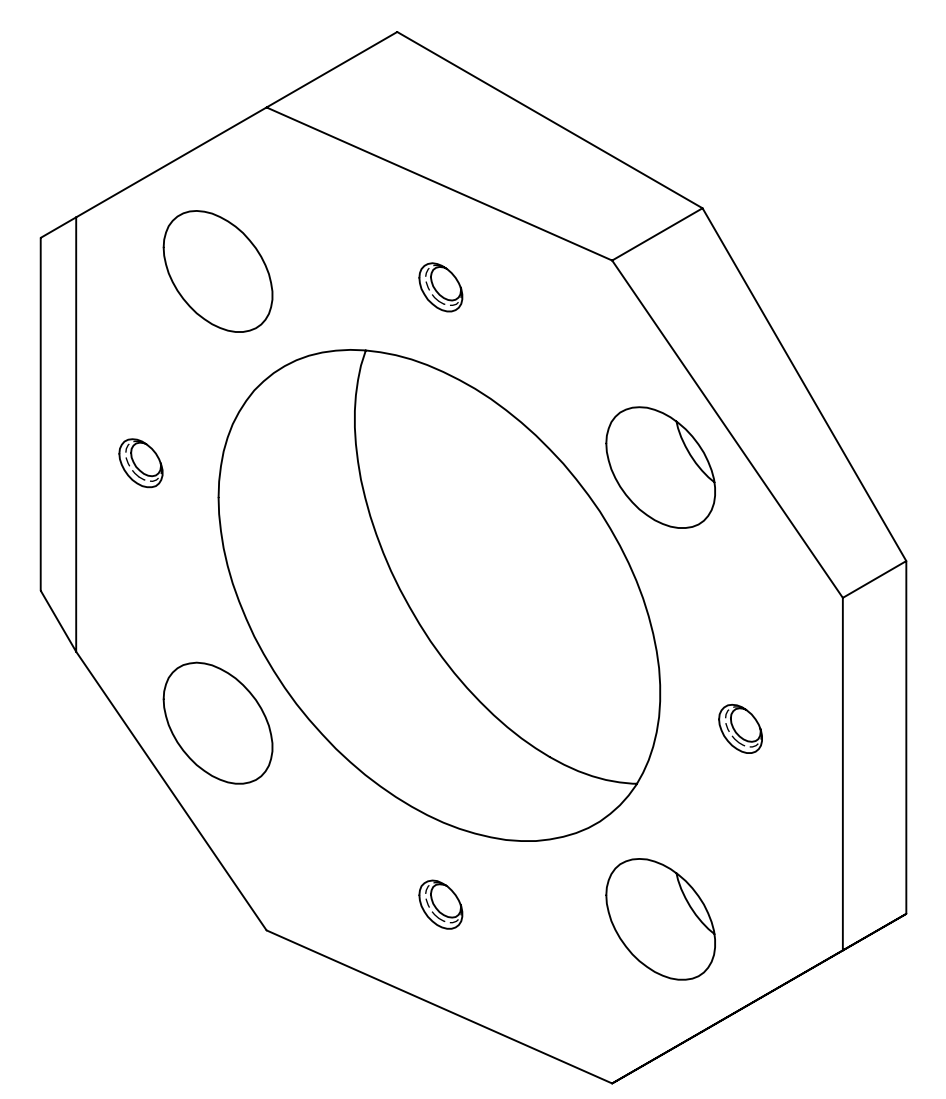
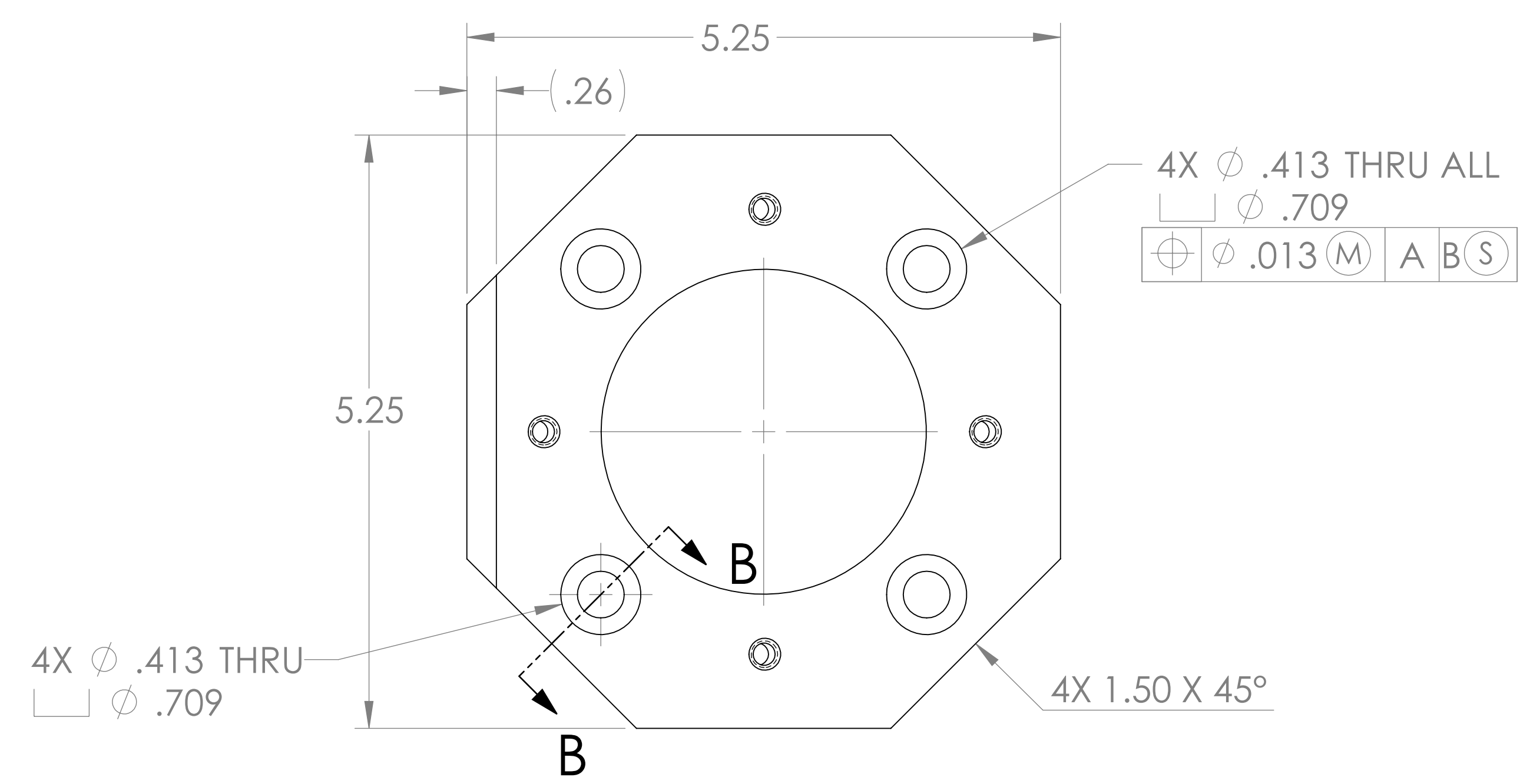

ISO VIEW

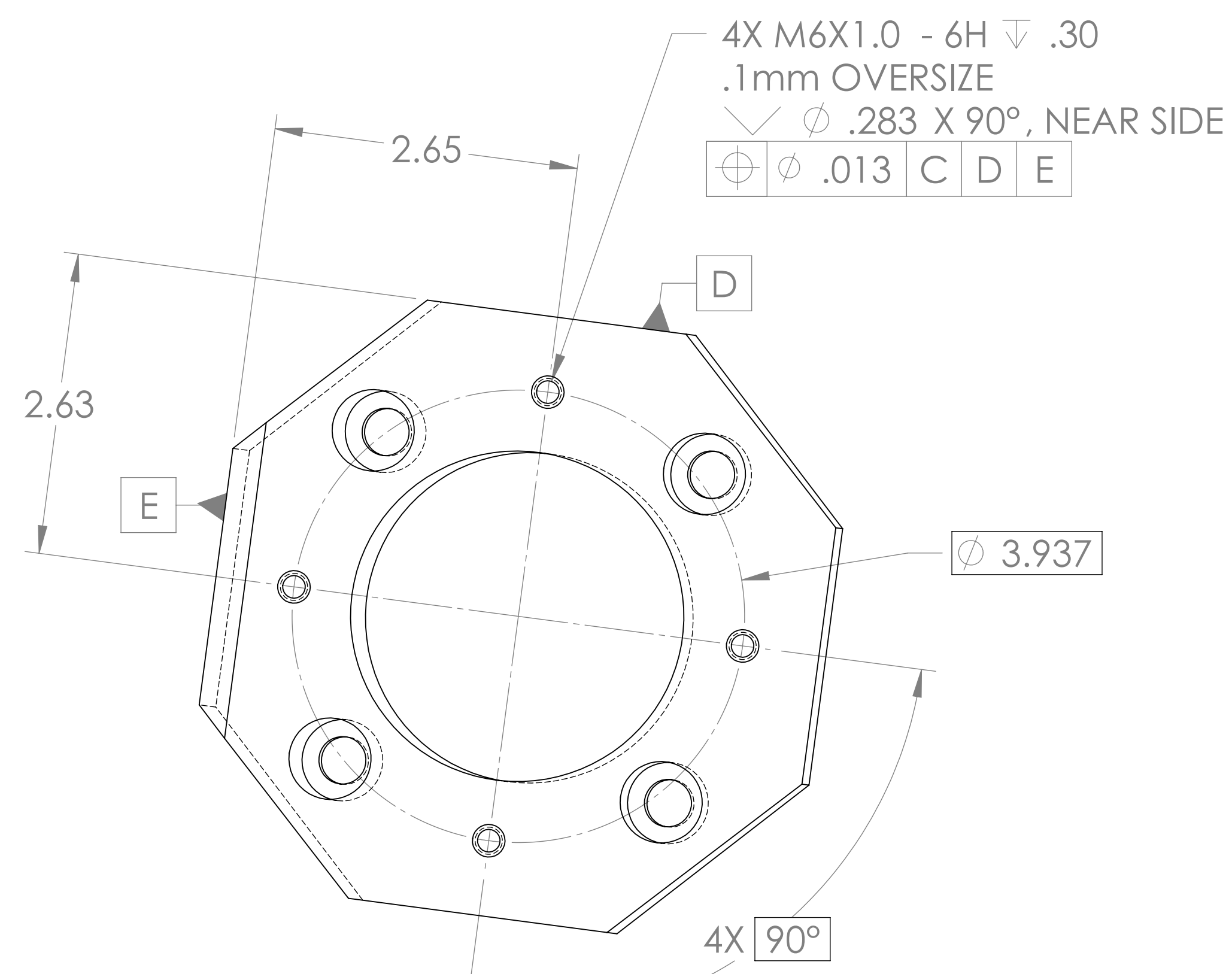
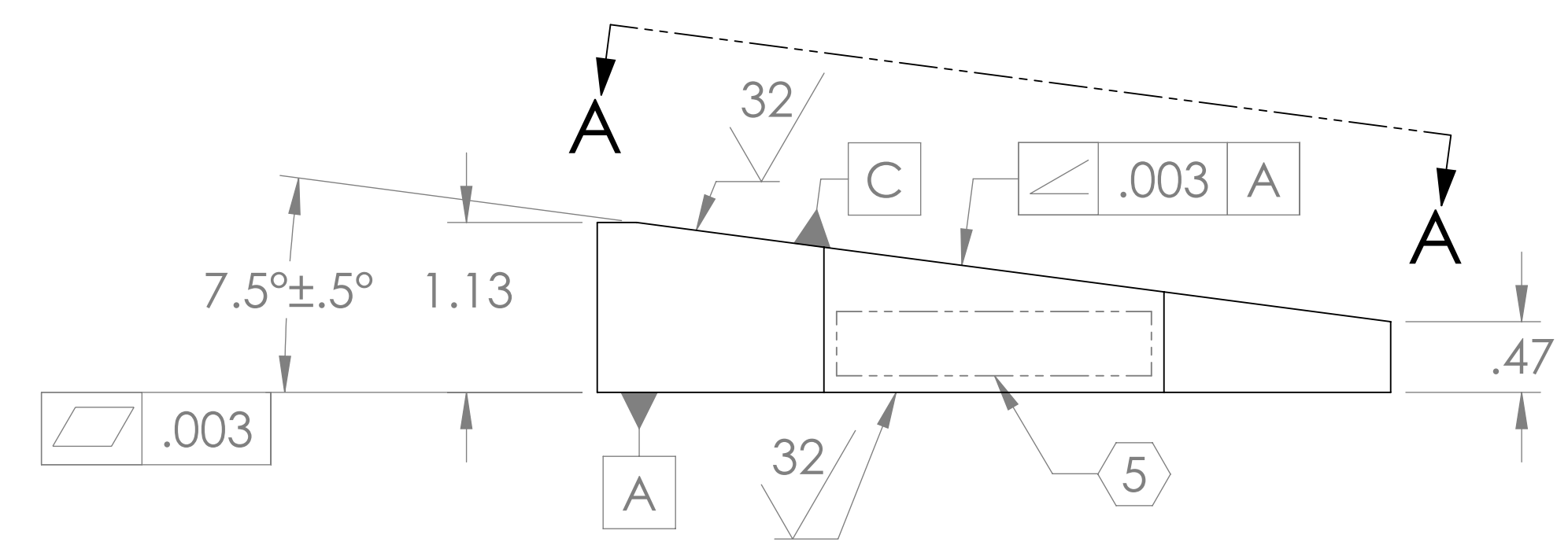

VIEW A-A

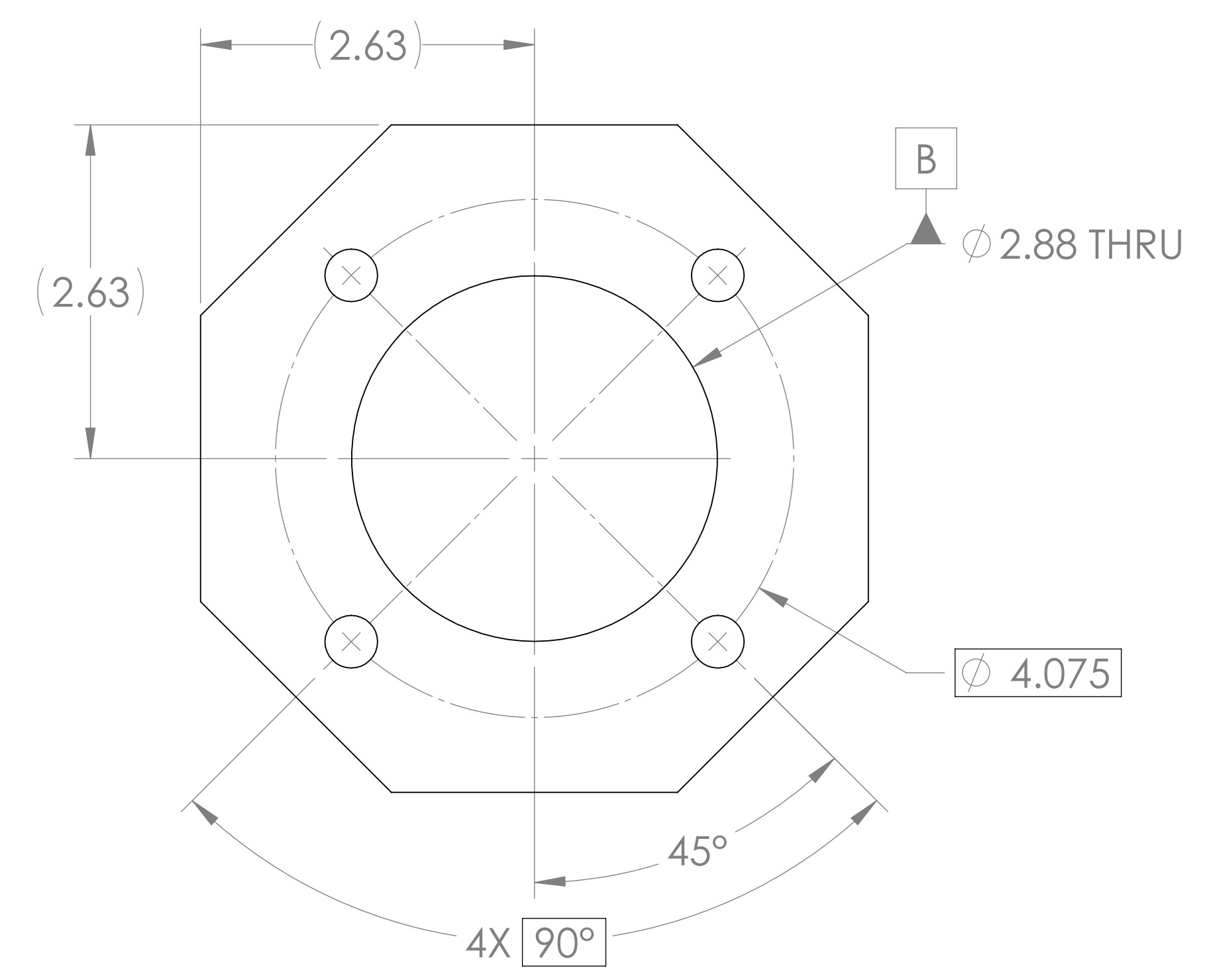

DIMENSIONS ARE IN INCHES		NOTES AND TOLERANCES: (UNLESS OTHERWISE SPECIFIED)		CALIFORNIA INSTITUTE OF TECHNOLOGY MASSACHUSETTS INSTITUTE OF TECHNOLOGY		PART NAME			
TOLERANCES: .XX ± .01 .XXX ± .005		1. INTERPRET DRAWING PER ASME Y14.5-1994. 2. REMOVE ALL SHARP EDGES, R.02 MIN. 3. DO NOT SCALE FROM DRAWING. 4. ALL MACHINING FLUIDS MUST BE FULLY SYNTHETIC, FULLY WATER SOLUBLE AND FREE OF SULFUR, SILICONE, AND CHLORINE.		SYSTEM <b>ADVANCED LIGO</b>		SUB-SYSTEM <b>AOS</b>		<b>ALIGO AOS OPLEV          TX MOUNTING PLATE, 7.5 DEG WEDGE</b>	
ANGULAR ± 1.0°		MATERIAL		NEXT ASSY		DESIGNER		SIZE DWG. NO.	
		304 SSSL		63 $\mu$ inch		D1000308		D <b>D1000510</b>	
		FINISH		APPROVAL		DESIGNER C. CONLEY 05 MAR 2009		CHECKER N. KILPATRICK 03 JUNE 2010	
						APPROVAL		SCALE: 1:1 PROJECTION:	
								SHEET 1 OF 1	

D1000510 ALIGO AOS Oplev TX Mounting Plate, 7.5 deg. Wedge, PART FROM REV. X-013, DRAWING FROM REV. X-015

NOTES CONTINUED:  
 ⑤ SCRIBE, ENGRAVE, OR MECHANICALLY STAMP (NO INKS OR DYES) DRAWING PART NUMBER, REVISION (AND VARIANT OR TYPE IF APPLICABLE ON NOTED SURFACE OR PART FOLLOWED ON THE NEXT LINE WITH A THREE DIGIT SERIAL NUMBER. SERIAL NUMBERS START AT 001 FOR THE FIRST ARTICLE AND PROCEED CONSECUTIVELY. USE MINIMUM 0.12" HIGH CHARACTERS UNLESS THE SIZE OF THE PART DICTATES SMALLER CHARACTERS. EXAMPLE: DXXXXXX-VY, TYPE-XX, S/N XXX. A VIBRATORY TOOL MAY BE USED.

REV.	DATE	DCN #	DRAWING TREE #
v1	07 JUNE 2010	E1000182-v1	-
v2	15 OCT 2010	E1000182-v2	-
-	-	-	-

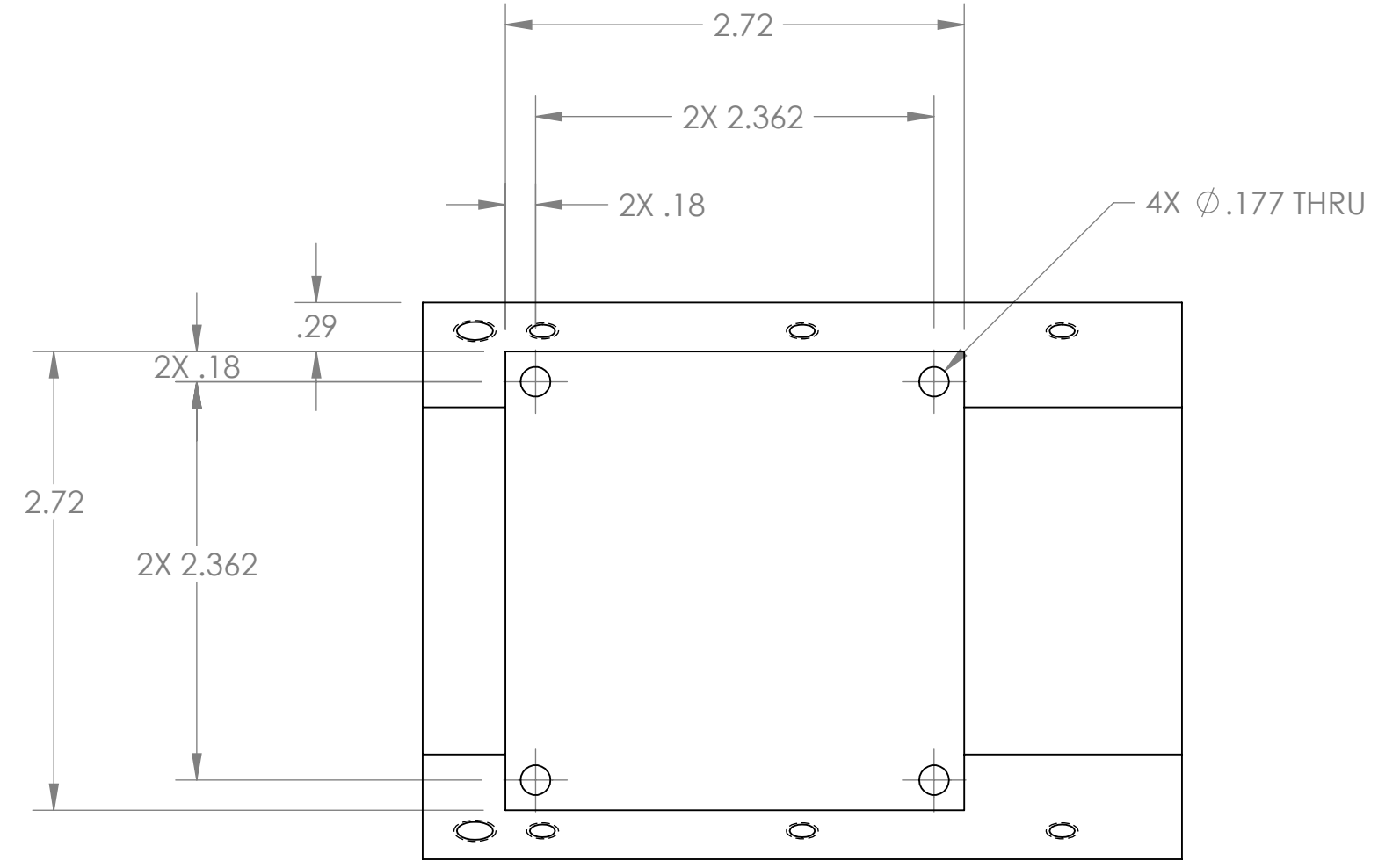
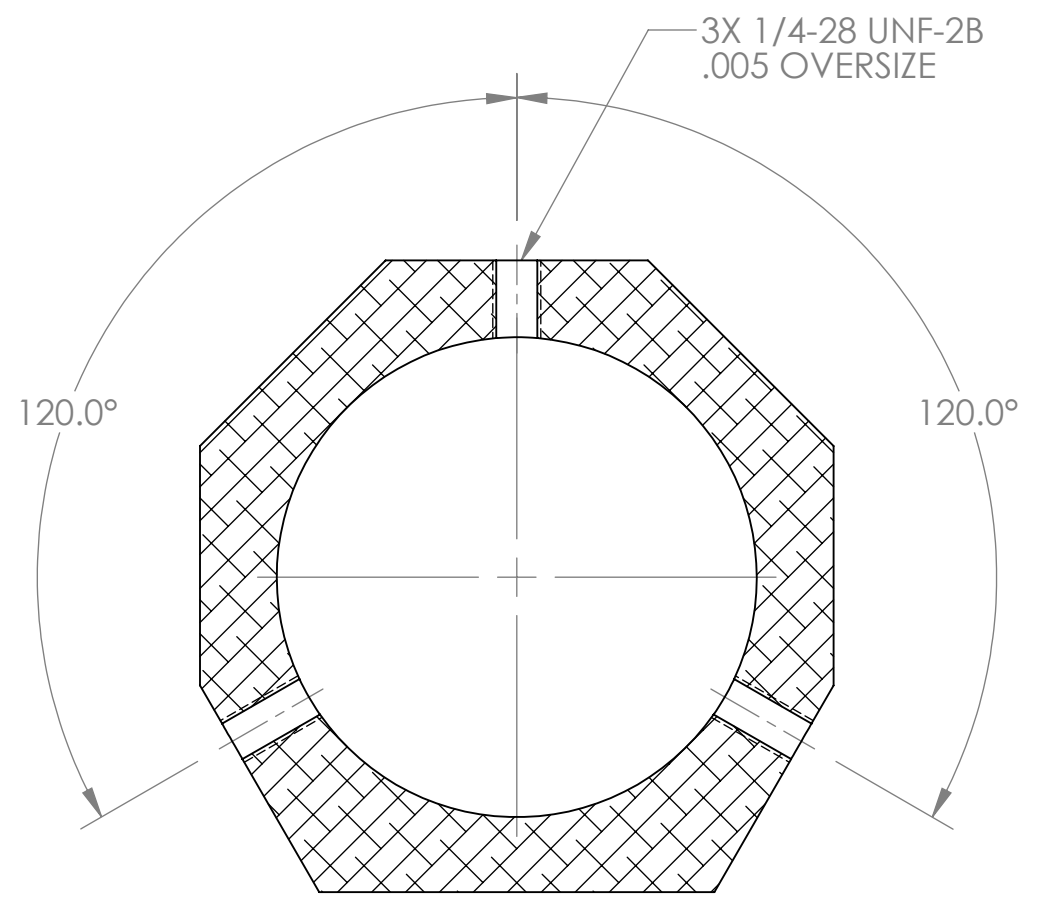
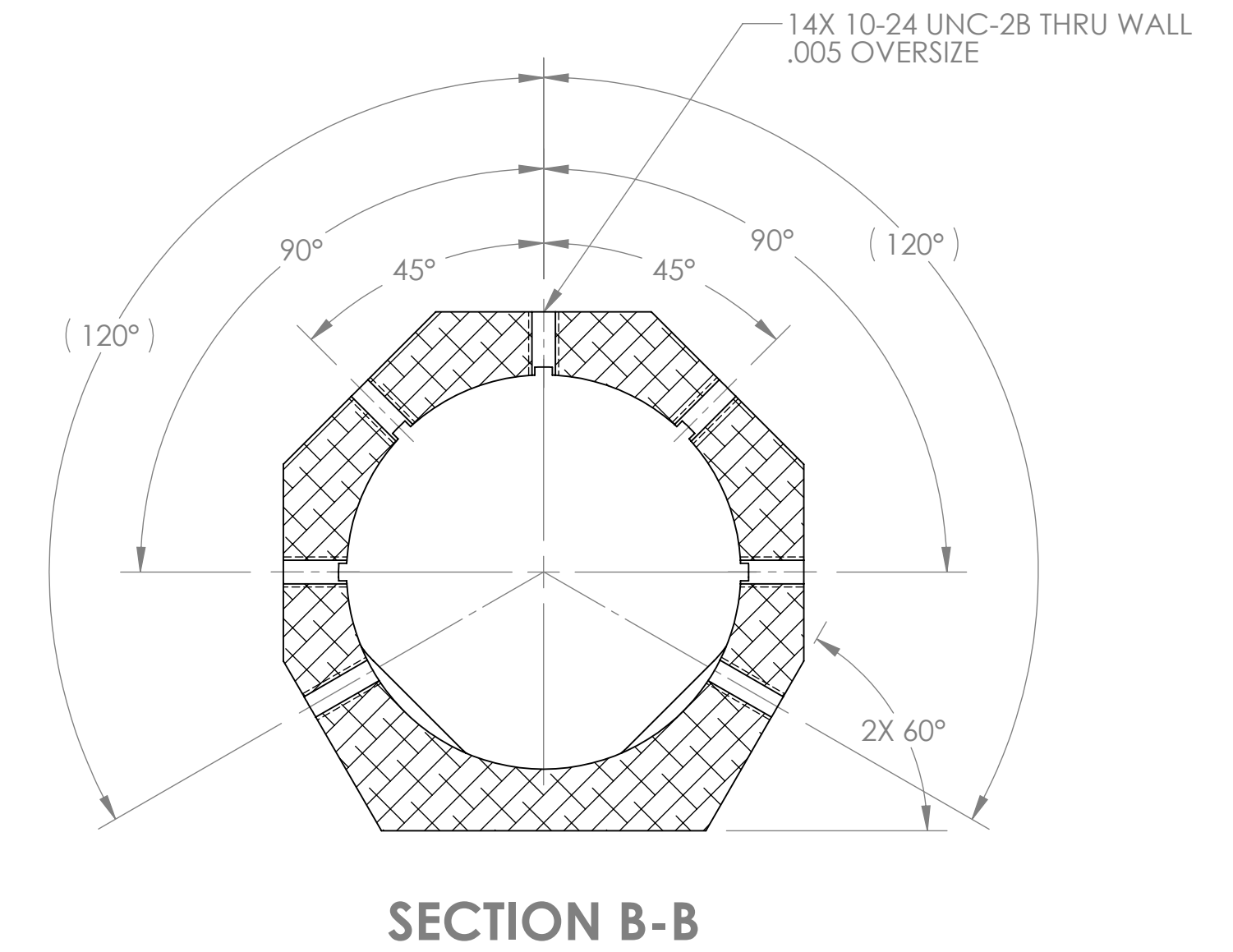
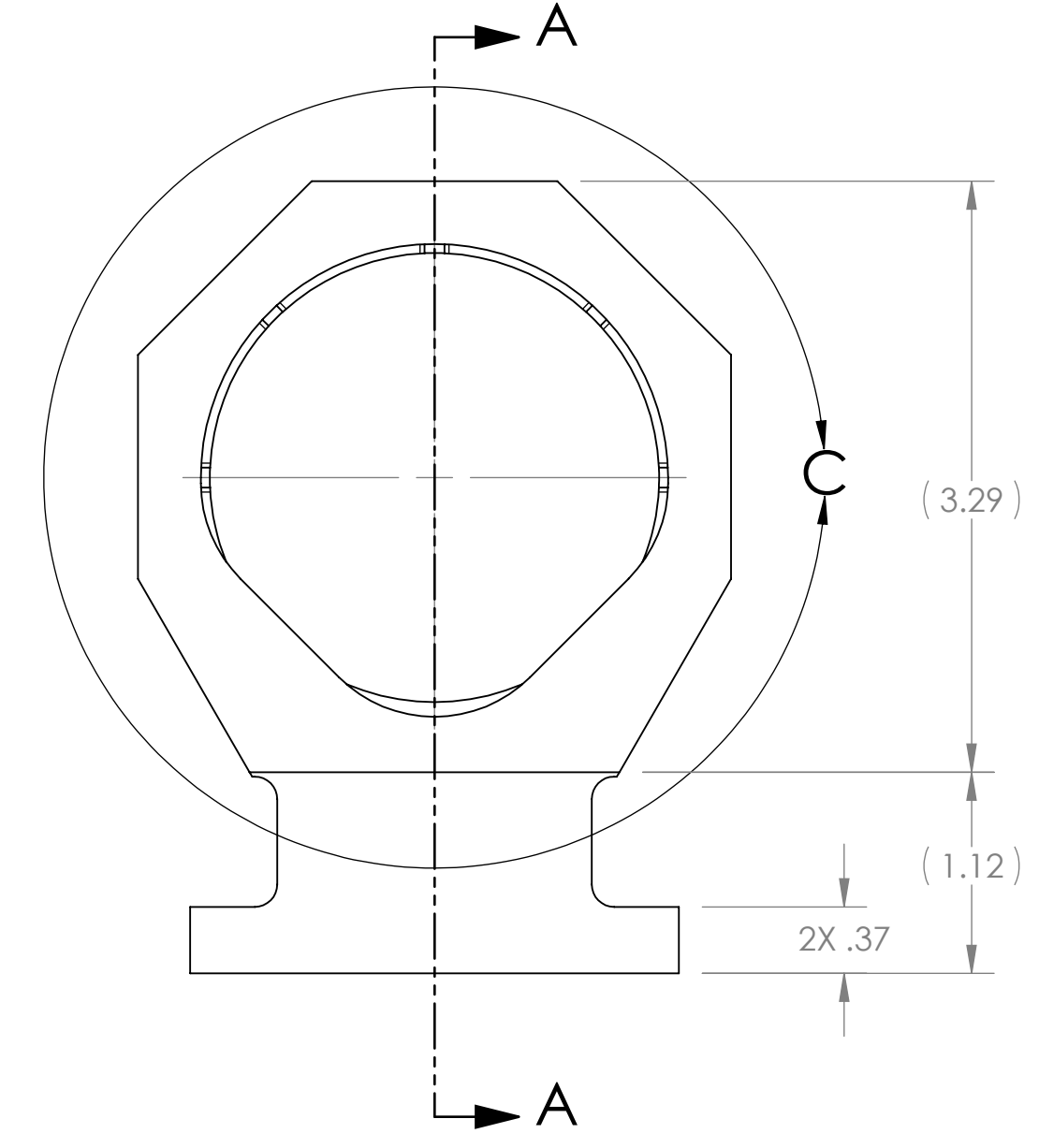
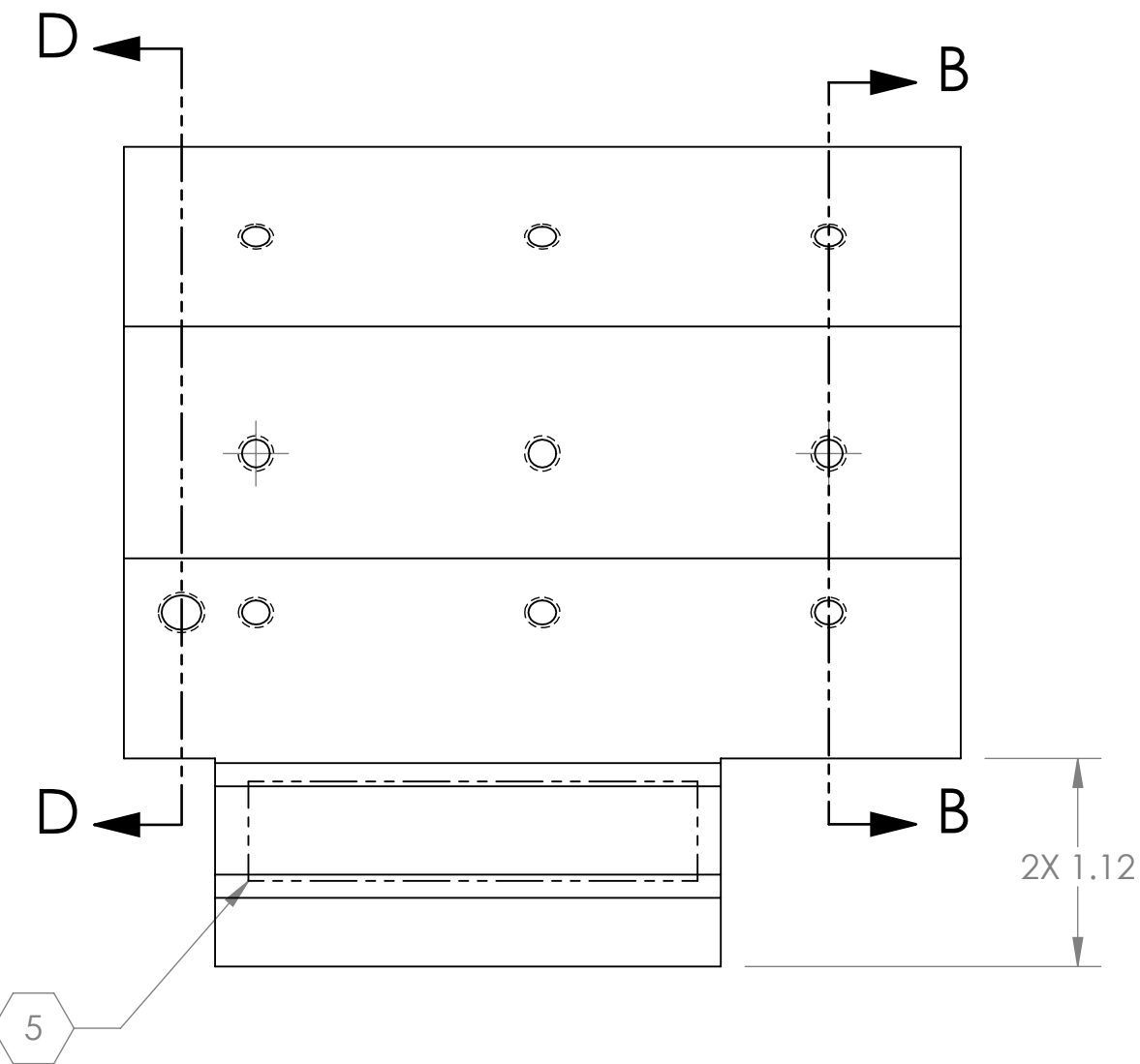
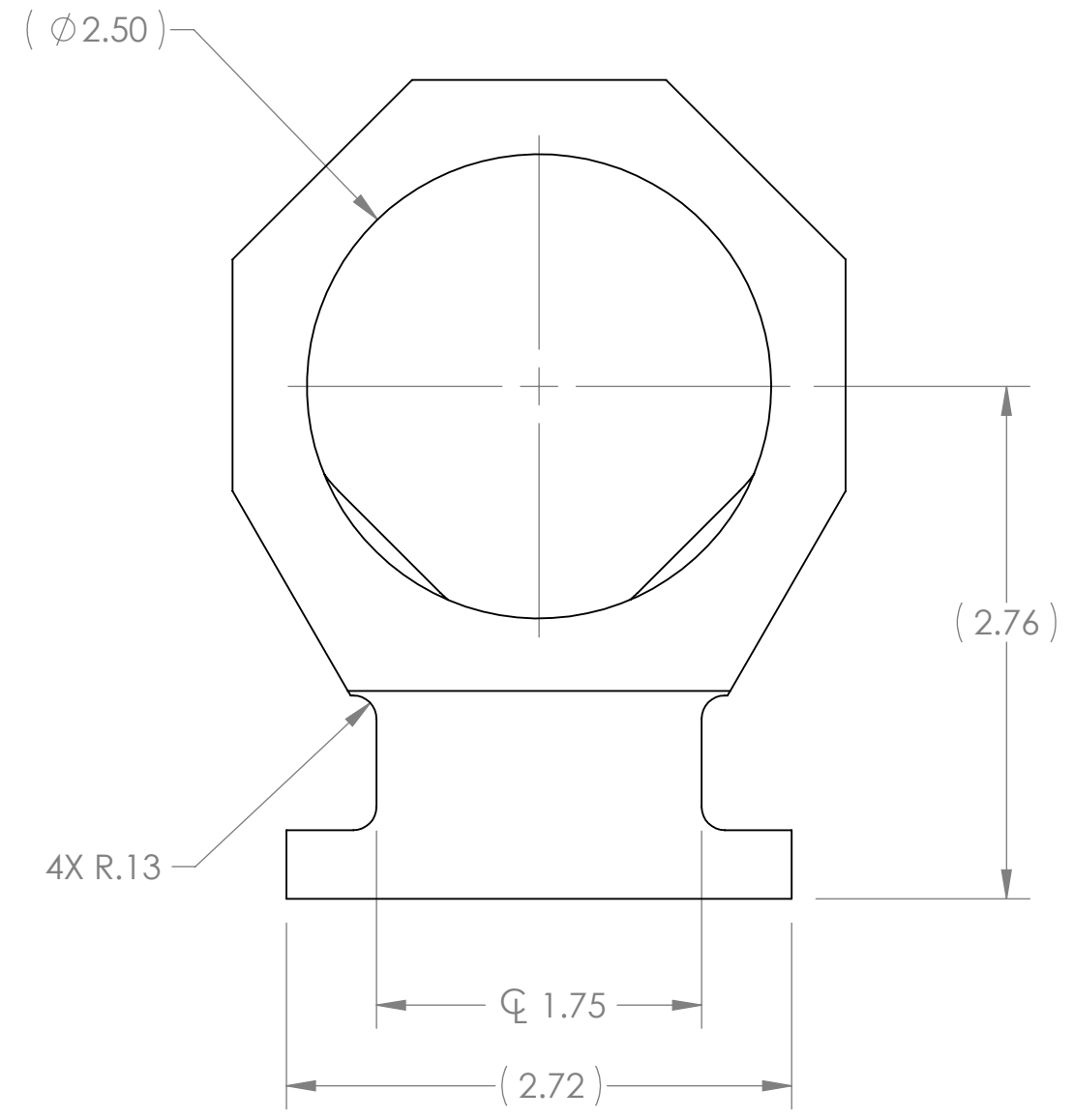
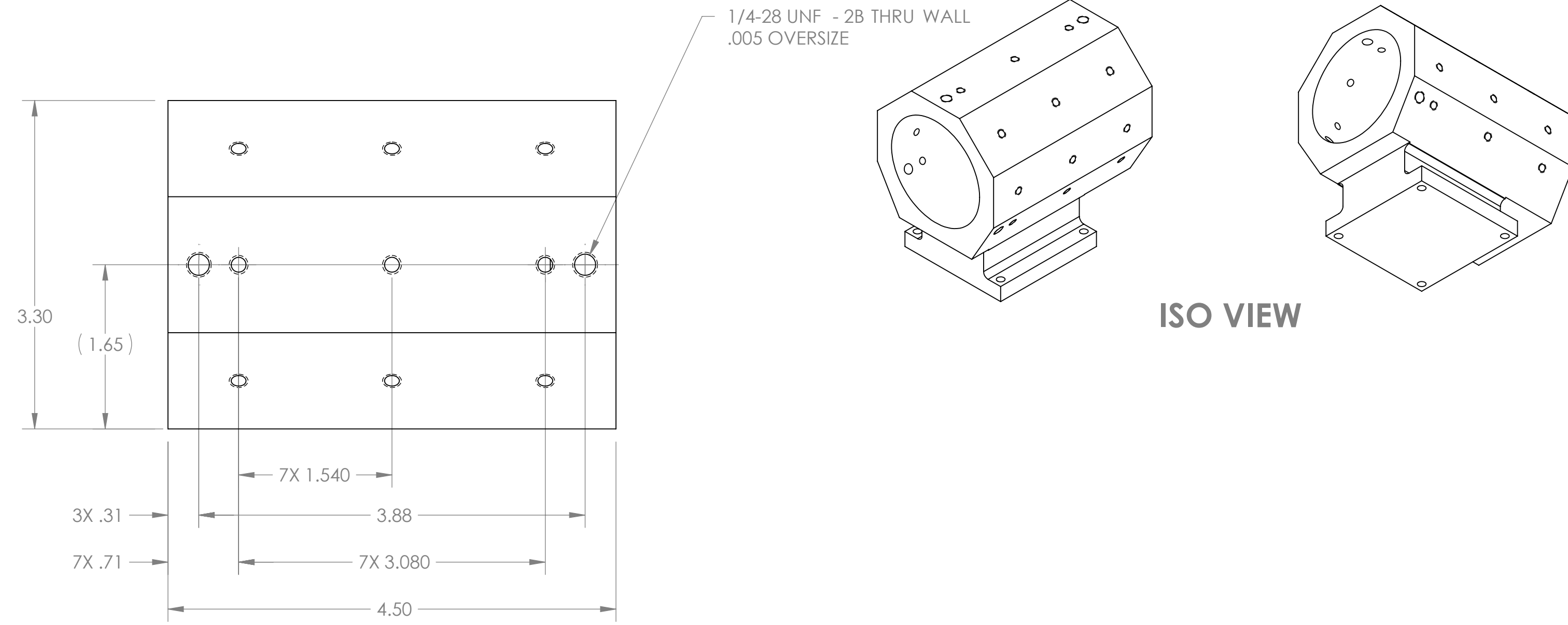

DIMENSIONS ARE IN INCHES		NOTES AND TOLERANCES: (UNLESS OTHERWISE SPECIFIED)		CALIFORNIA INSTITUTE OF TECHNOLOGY MASSACHUSETTS INSTITUTE OF TECHNOLOGY		PART NAME	
TOLERANCES: .XX ± .01 .XXX ± .005		1. INTERPRET DRAWING PER ASME Y14.5-1994. 2. REMOVE ALL SHARP EDGES, R.02 MIN. 3. DO NOT SCALE FROM DRAWING. 4. ALL MACHINING FLUIDS MUST BE FULLY SYNTHETIC, FULLY WATER SOLUBLE AND FREE OF SULFUR, SILICONE, AND CHLORINE.		SYSTEM <b>ADVANCED LIGO</b>		SUB-SYSTEM <b>AOS</b>	
ANGULAR ± 1.0°		MATERIAL		NEXT ASSY		DESIGNER C. CONLEY 06 JUN 2010	
		6061-T6 Al		D1001335 D1001339		SIZE DWG. NO. <b>D D1001449</b>	
		FINISH				CHECKER N. KILPATRICK 07 JUNE 2010	
		63 µinch				APPROVAL SCALE: 1:1 PROJECTION:	
						REV. <b>v2</b>	
						SHEET 1 OF 2	

D1001449 ALIGO AOS Oplev Large Telescope Mount PART PDM REV: X.011 DRAWING PDM REV: X.010

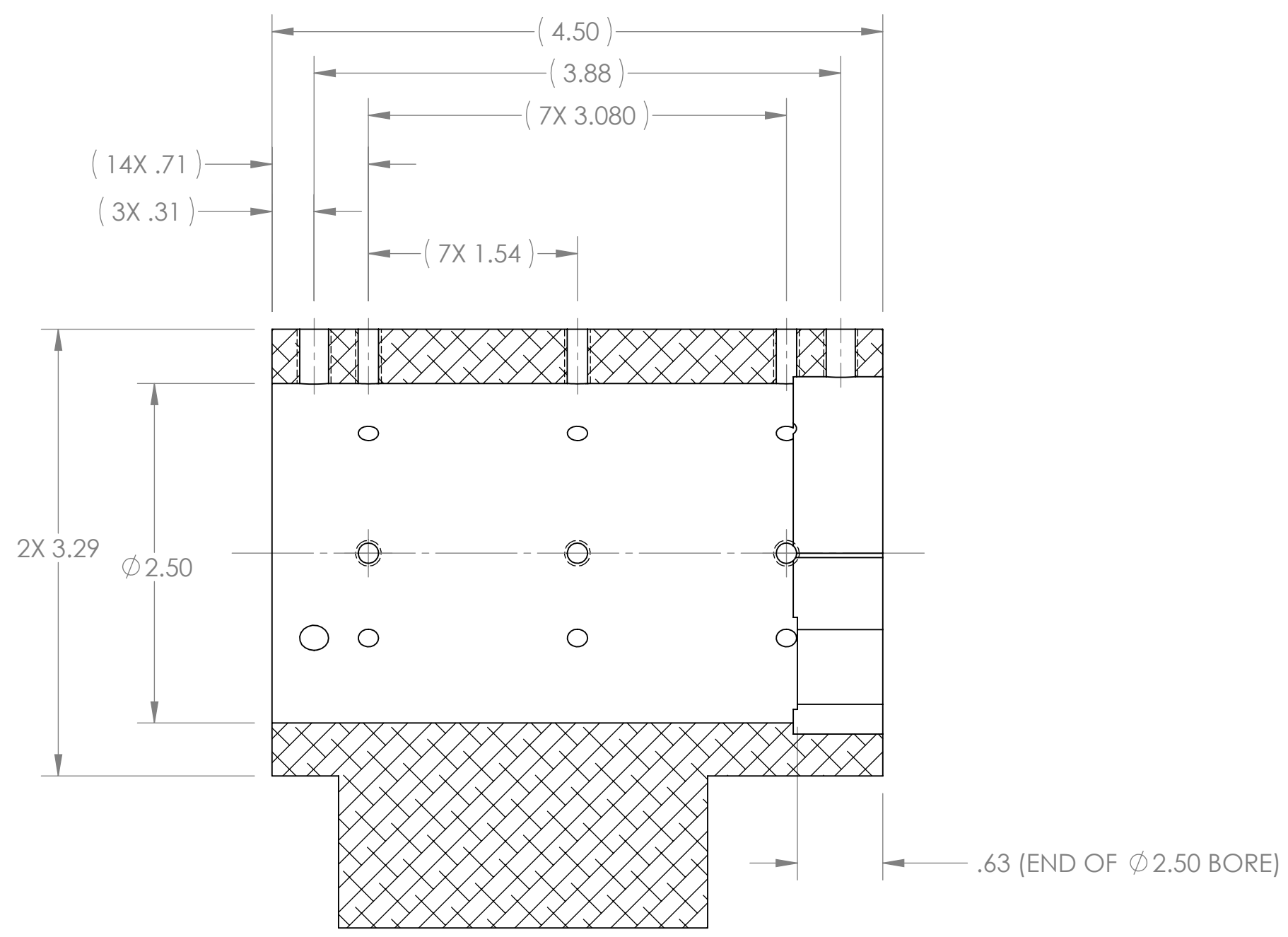

SECTION A-A

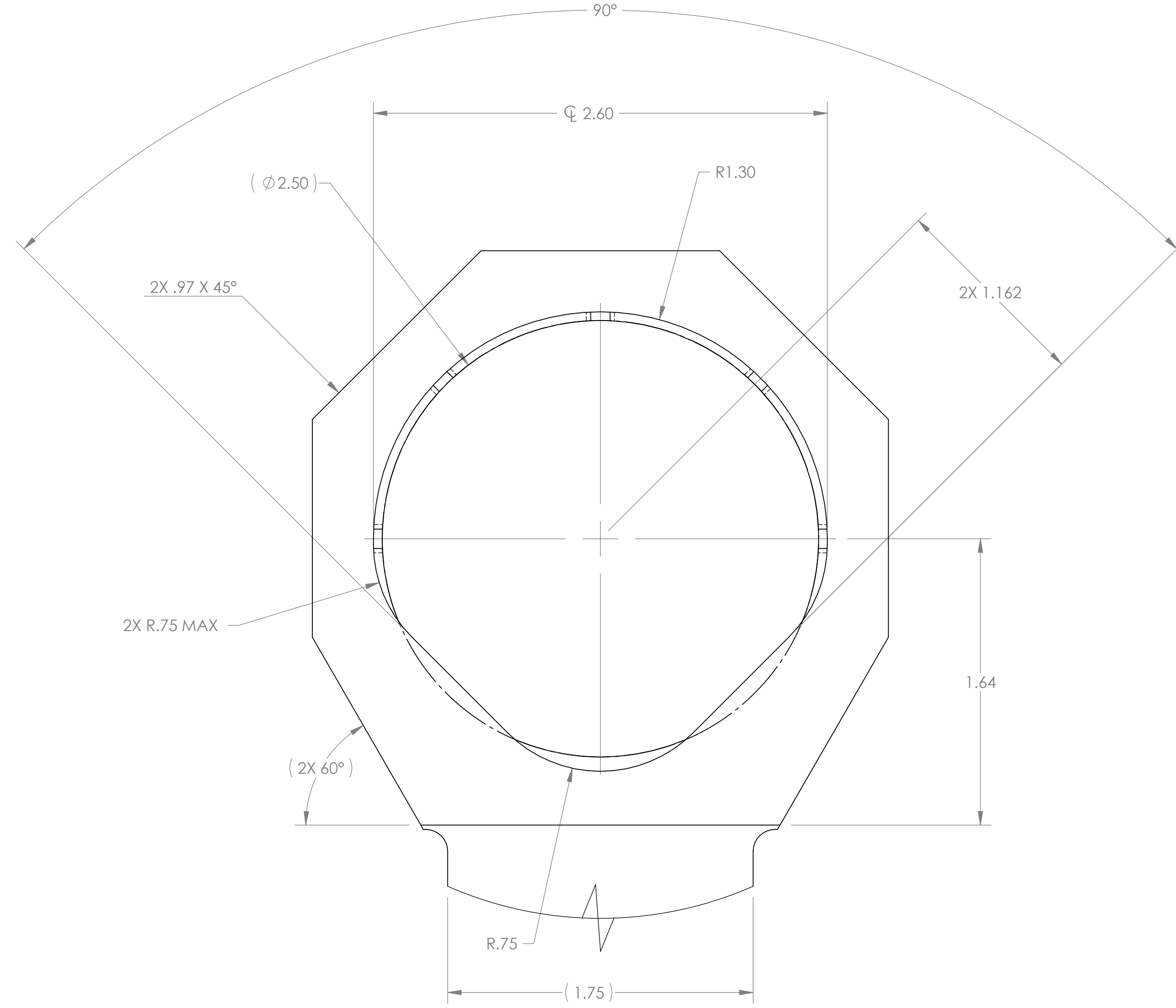

DETAIL C  
SCALE 2 : 1

D1001449.dwg ACS C:\lsc\lsc\Large Telescope Mount\_PART PDM REV: X.011, DRAWING PDM REV: X.010

NOTES CONTINUED:  
 ⑤ SCRIBE, ENGRAVE, OR MECHANICALLY STAMP (NO INKS OR DYES) DRAWING PART NUMBER, REVISION (AND VARIANT OR TYPE IF APPLICABLE) ON NOTED SURFACE OF PART FOLLOWED ON THE NEXT LINE WITH A THREE DIGIT SERIAL NUMBER. SERIAL NUMBERS START AT 001 FOR THE FIRST ARTICLE AND PROCEED CONSECUTIVELY. USE MINIMUM 0.12" HIGH CHARACTERS, UNLESS THE SIZE OF THE PART DICTATES SMALLER CHARACTERS. A VIBRATORY TOOL MAY BE USED. EXAMPLE: DXXXXXX-VY, TYPE-XX, S/N XXX

REV.	DATE	DCN #	DRAWING TREE #
v1	10 JUNE 2010	E1000182-v1	-
-	-	-	-
-	-	-	-

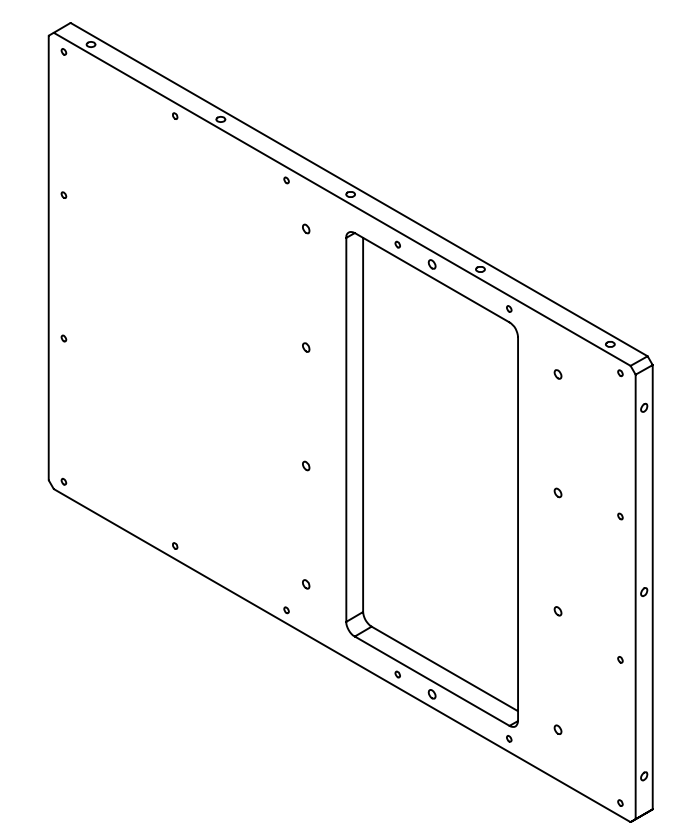
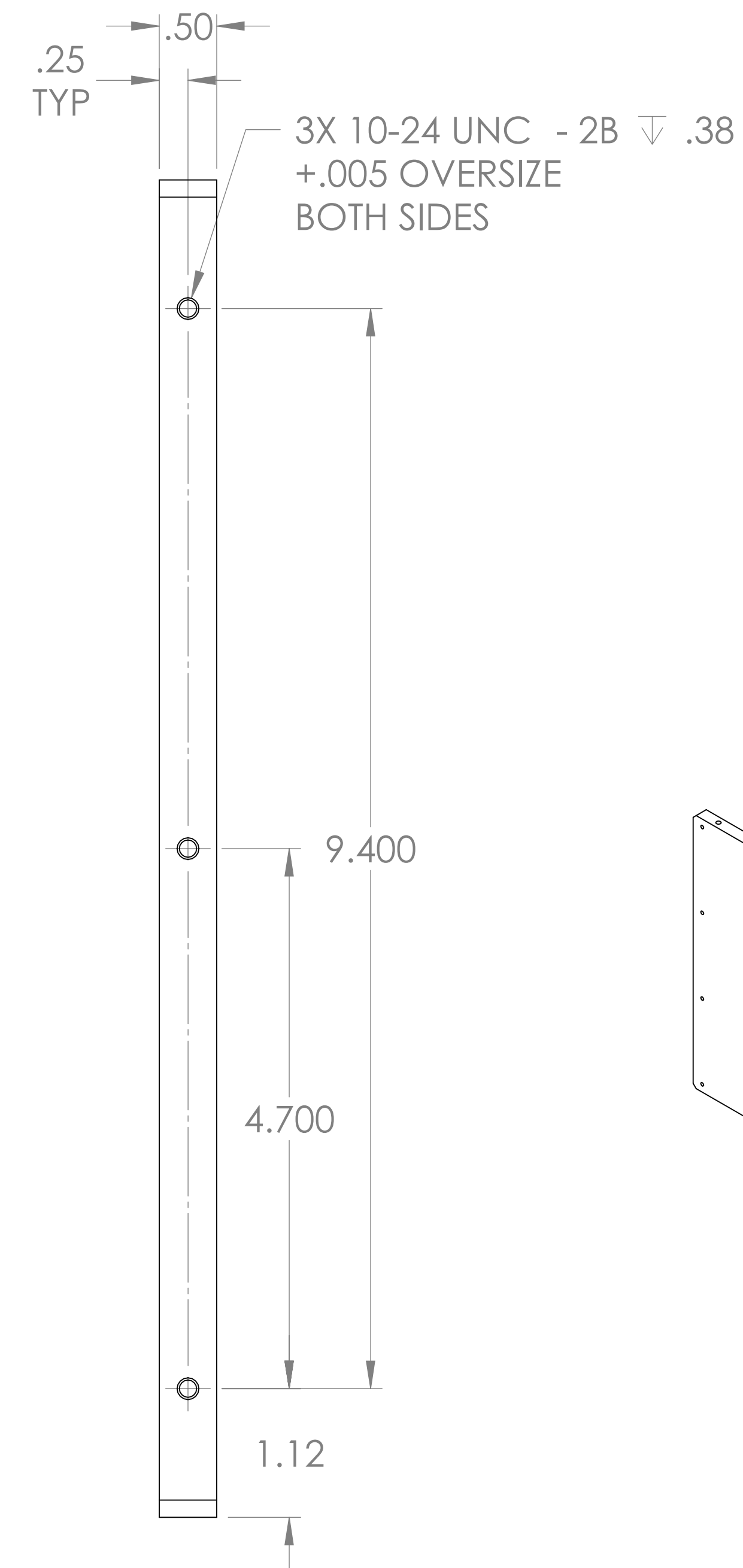
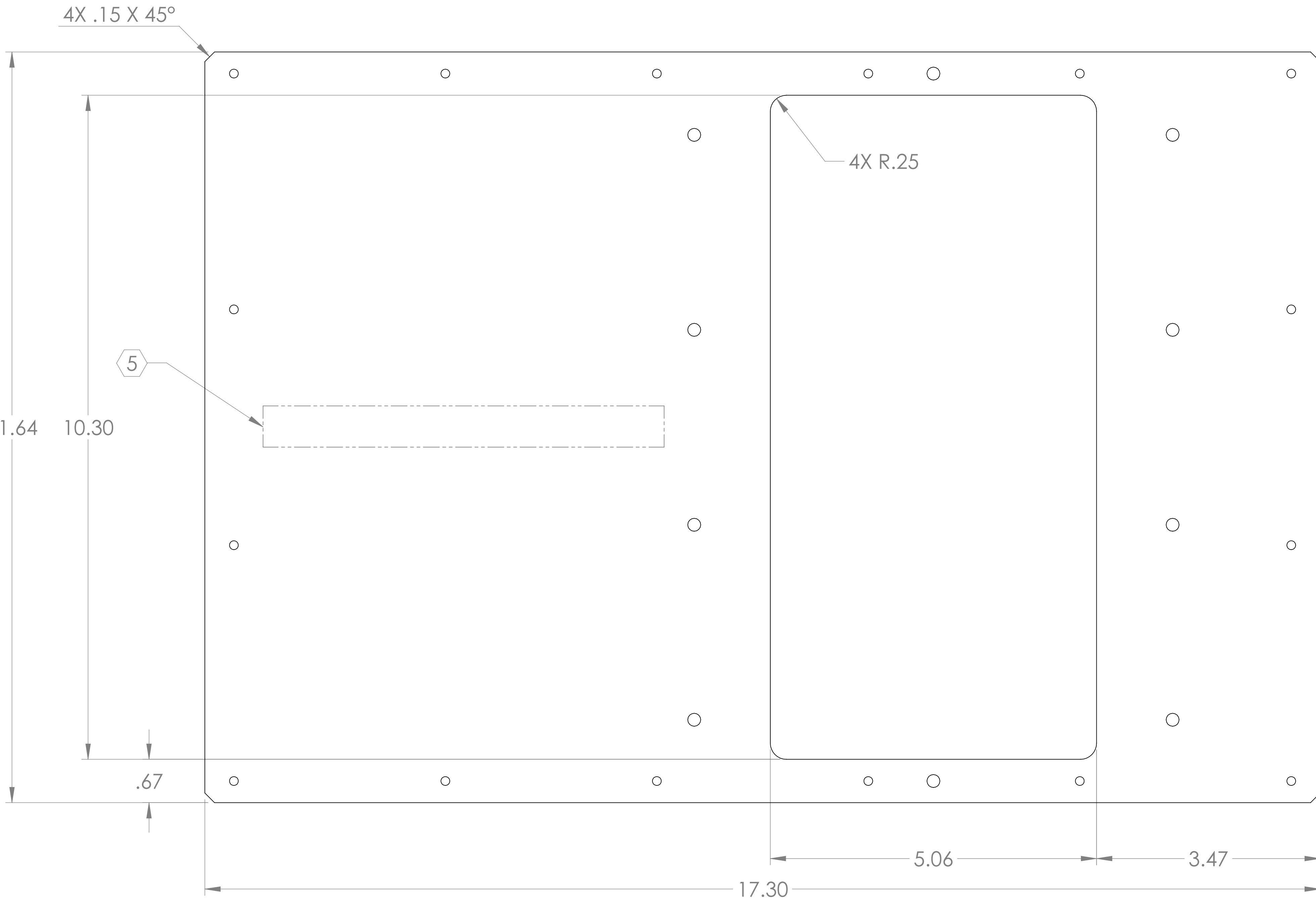
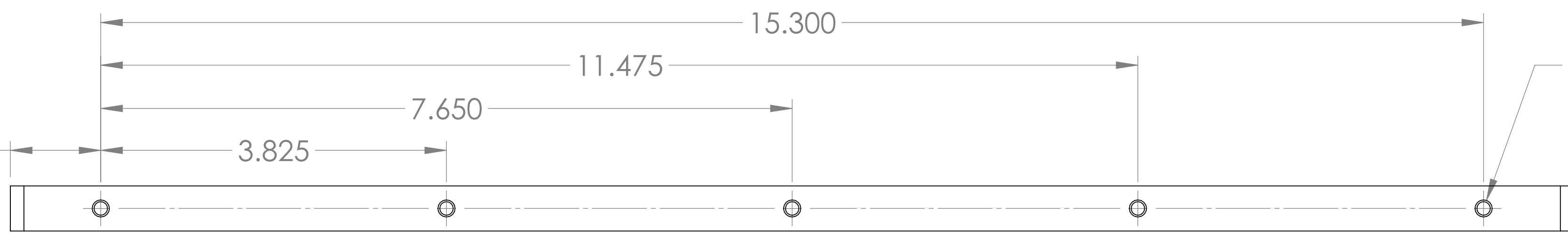

ISO VIEW

DIMENSIONS ARE IN INCHES		NOTES AND TOLERANCES: (UNLESS OTHERWISE SPECIFIED)		CALIFORNIA INSTITUTE OF TECHNOLOGY MASSACHUSETTS INSTITUTE OF TECHNOLOGY		PART NAME	
TOLERANCES: .XX ± .01 .XXX ± .005		1. INTERPRET DRAWING PER ASME Y14.5-1994. 2. REMOVE ALL SHARP EDGES, R.02 MIN. 3. DO NOT SCALE FROM DRAWING. 4. ALL MACHINING FLUIDS MUST BE FULLY SYNTHETIC, FULLY WATER SOLUBLE AND FREE OF SULFUR, SILICONE, AND CHLORINE.		SYSTEM ADVANCED LIGO SUB-SYSTEM AOS		ALIGO AOS OPLEV TX ENCLOSURE BASE	
ANGULAR ± 1.0°		MATERIAL 304 SSSL FINISH 63 μinch		NEXT ASSY D1000308 D1001335 D1001339		DESIGNER C. CONLEY 06 JUN 2010 DRAFTER N. KILPATRICK 10 JUNE 2010 CHECKER APPROVAL	
						SIZE DWG. NO. D D1001452 SCALE: 1:1 PROJECTION:	
						REV. v1 SHEET 1 OF 2	

D1001452.dwg AOS Oplev TX Enclosure Base PART FDM REV: X-023 DRAWING FDM REV: X-017



8 7 6 5 4 3 2 1

H  
G  
F  
E  
D  
C  
B  
A

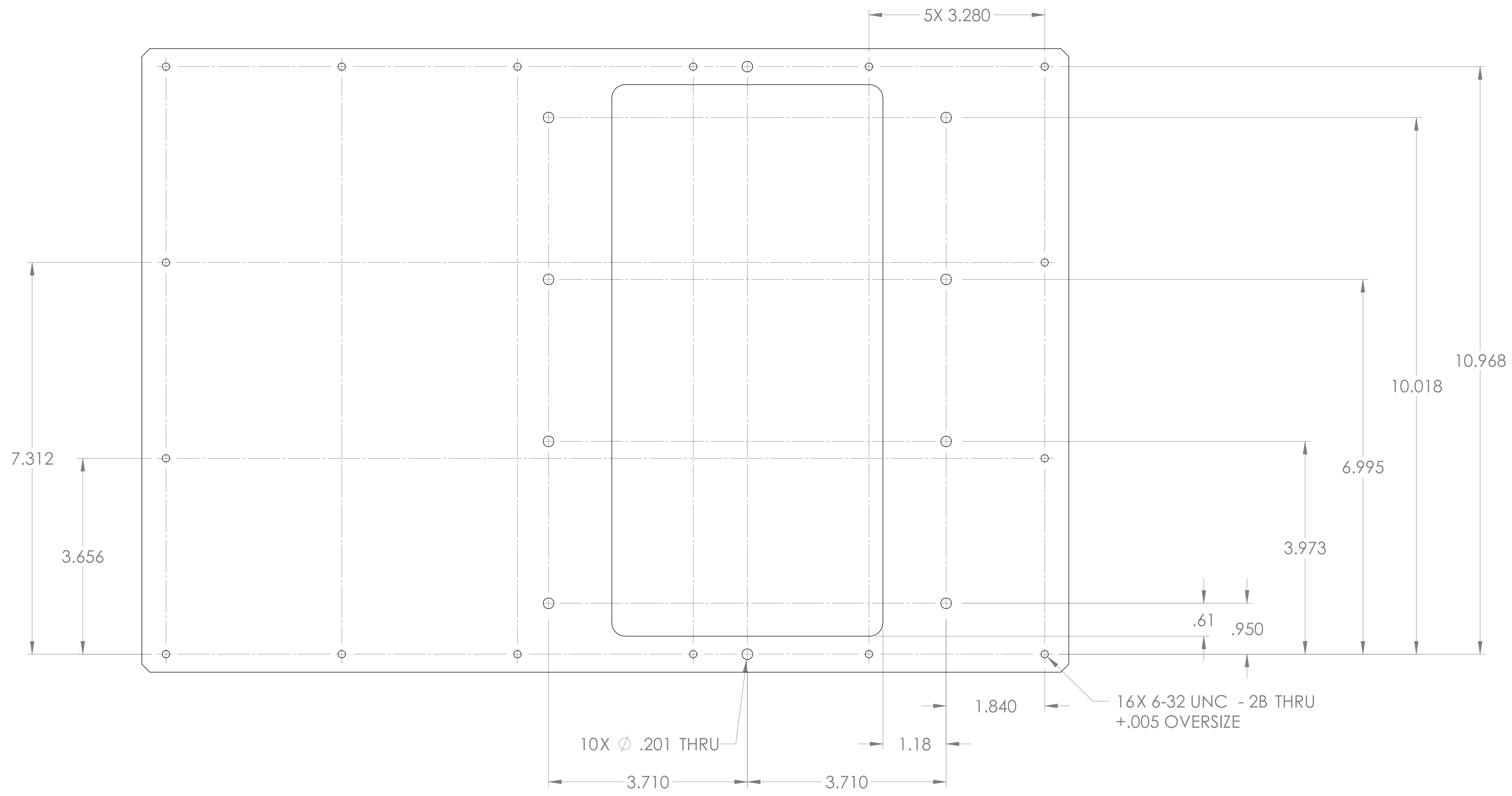

**LIGO** CALIFORNIA INSTITUTE OF TECHNOLOGY  
MASSACHUSETTS INSTITUTE OF TECHNOLOGY

SIZE	DWG. NO.	REV.
D	D1001452	v1
SCALE: 1:1	PROJECTION:	SHEET 2 OF 2

D:\001452.dwg\ACS Client\TX Enclosure Base PART FDM REV: X-023 DRAWING FDM REV: X-017

8 7 6 5 4 3 2 1

8 7 6 5 4 3 2 1

**NOTES CONTINUED:**  
 5. SCRIBE, ENGRAVE, OR MECHANICALLY STAMP (NO INKS OR DYES) DRAWING PART NUMBER, REVISION (AND VARIANT OR "TYPE" IF APPLICABLE) ON NOTED SURFACE OF PART FOLLOWED ON THE NEXT LINE WITH A THREE DIGIT SERIAL NUMBER. SERIAL NUMBERS START AT 001 FOR THE FIRST ARTICLE AND PROCEED CONSECUTIVELY. USE MINIMUM 0.12" HIGH CHARACTERS, UNLESS THE SIZE OF THE PART DICTATES SMALLER CHARACTERS. A VIBRATORY TOOL MAY BE USED.  
 EXAMPLE: DXXXXXX-VY, TYPE-XX, S/N XXX

REV.	DATE	DCN #	DRAWING TREE #
v1	19 AUG 2010	E1000182-v1	-
-	-	-	-
-	-	-	-

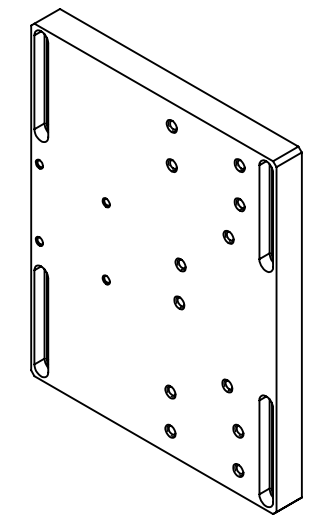
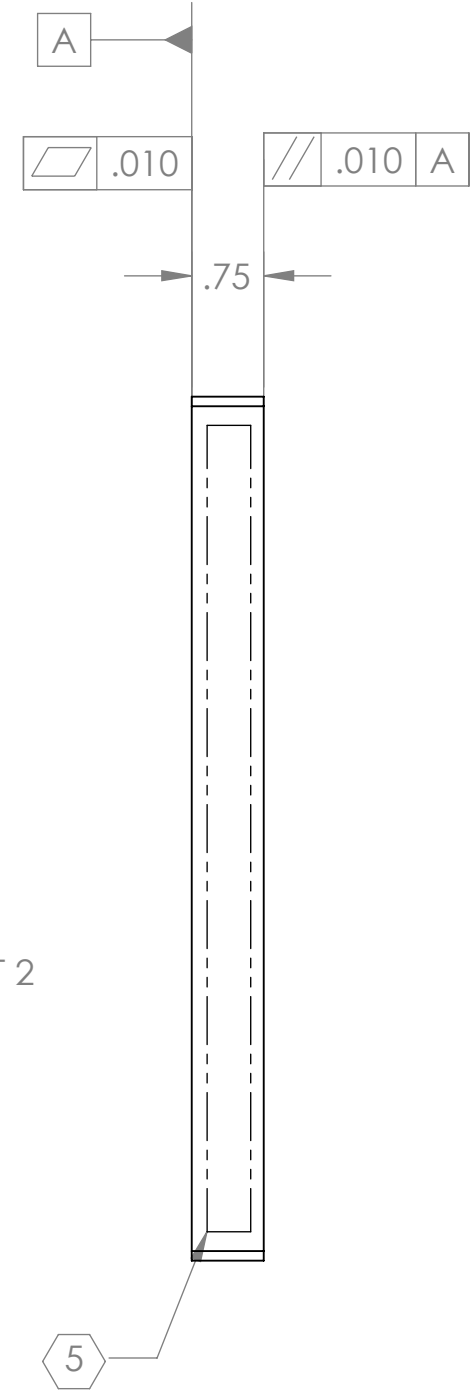
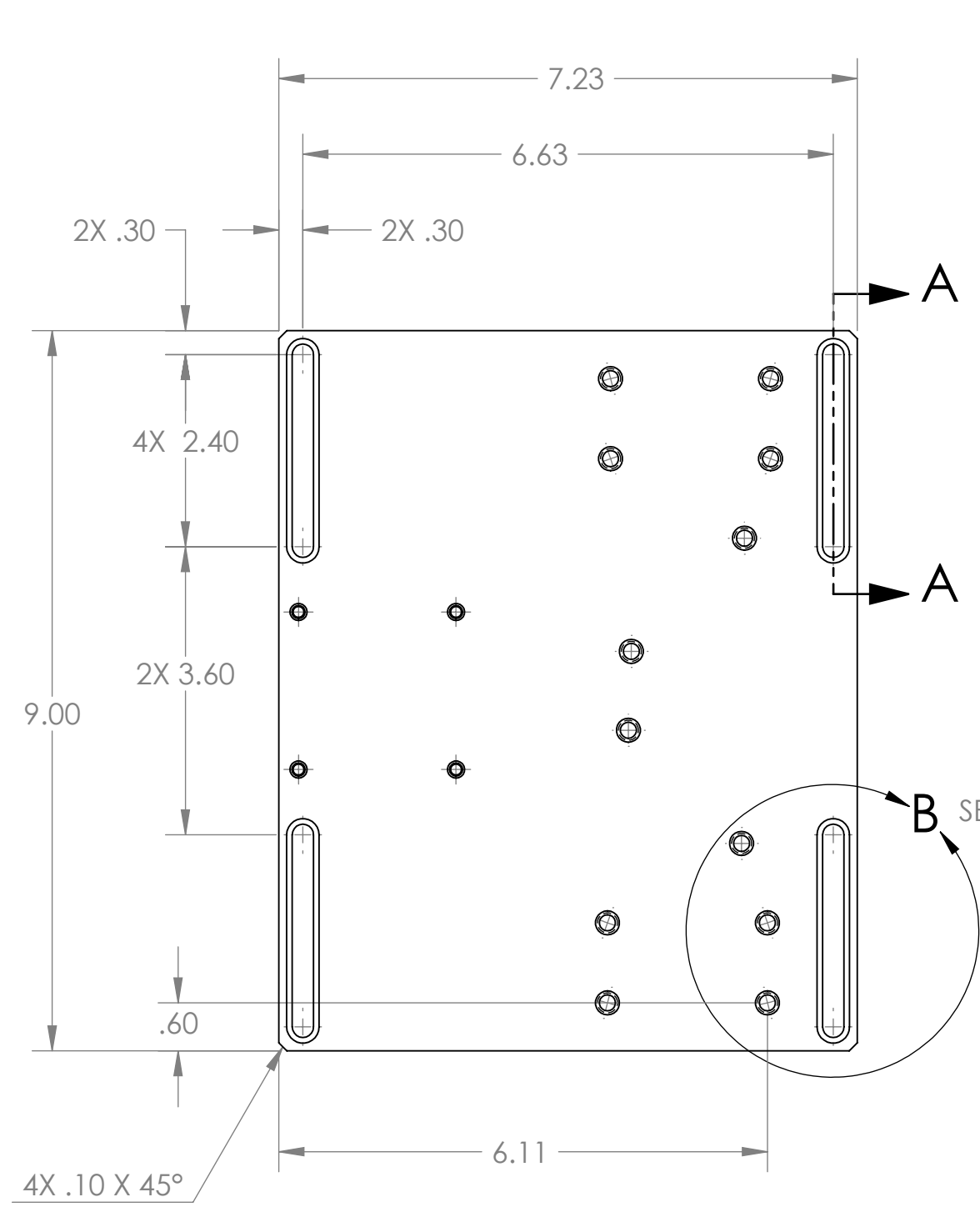

**ISO VIEW**

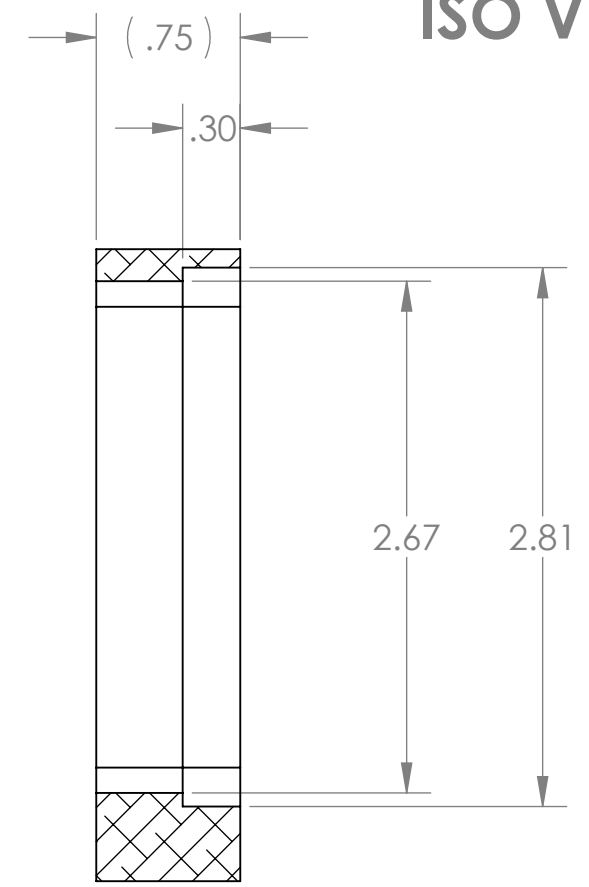

**SECTION A-A  
SCALE 1 : 1**

- 8. MACHINE ALL SURFACES TO REMOVE OXIDES AND MILL FINISH, USE OF ABRASIVE TECHNIQUES IS NOT ALLOWED.
- 7. DO NOT USE SANDPAPER, SCOTCH BRITE OR SIMILAR PRODUCTS.
- 6. ALL PARTS SHALL BE MANUFACTURED IN ACCORDANCE WITH LIGO SPECIFICATION E0900364.

NOTES AND TOLERANCES: (UNLESS OTHERWISE SPECIFIED)	
DIMENSIONS ARE IN INCHES	
TOLERANCES: .XX ± .01 .XXX ± .005	
ANGULAR ± 1.0°	
1. INTERPRET DRAWING PER ASME Y14.5-1994. 2. REMOVE ALL SHARP EDGES, R.02 MIN. 3. DO NOT SCALE FROM DRAWING. 4. ALL MACHINING FLUIDS MUST BE FULLY SYNTHETIC, FULLY WATER SOLUBLE AND FREE OF SULFUR, SILICONE, AND CHLORINE.	
MATERIAL	6061-T6 Al
FINISH	N/A μinch

CALIFORNIA INSTITUTE OF TECHNOLOGY MASSACHUSETTS INSTITUTE OF TECHNOLOGY		PART NAME		ALIGO AOS	
SYSTEM		SUB-SYSTEM		OPLEV MOUNTING PLATE (HAM)	
ADVANCED LIGO		AOS		DESIGNER	C. CONLEY 07 MAY 2009
NEXT ASSY		D0900423		DRAFTER	N. KILPATRICK 19 AUG 2010
				CHECKER	
				APPROVAL	
				SIZE	DWG. NO.
				B	D1001627
				SCALE:	1:2
				PROJECTION:	ASME
				SHEET 1 OF 2	

D1001627 alIGO AOS Oplev Mounting Plate (HAM), PART PDM REV: X-011, DRAWING PDM REV: X-005

8 7 6 5 4 3 2 1

D1001627 dLIGO AOS Oplev Mounting Plate (HAM), PART PDM REV: X-011, DRAWING PDM REV: X-005

12X 1/4-20 UNC - 2B THRU  
∠  $\phi$  .300 X 90°, NEAR SIDE  
+.005" OVERSIZE

4X 8-32 UNC - 2B  $\nabla$  .328  
∠  $\phi$  .214 X 90°, NEAR SIDE  
+.005" OVERSIZE TAP

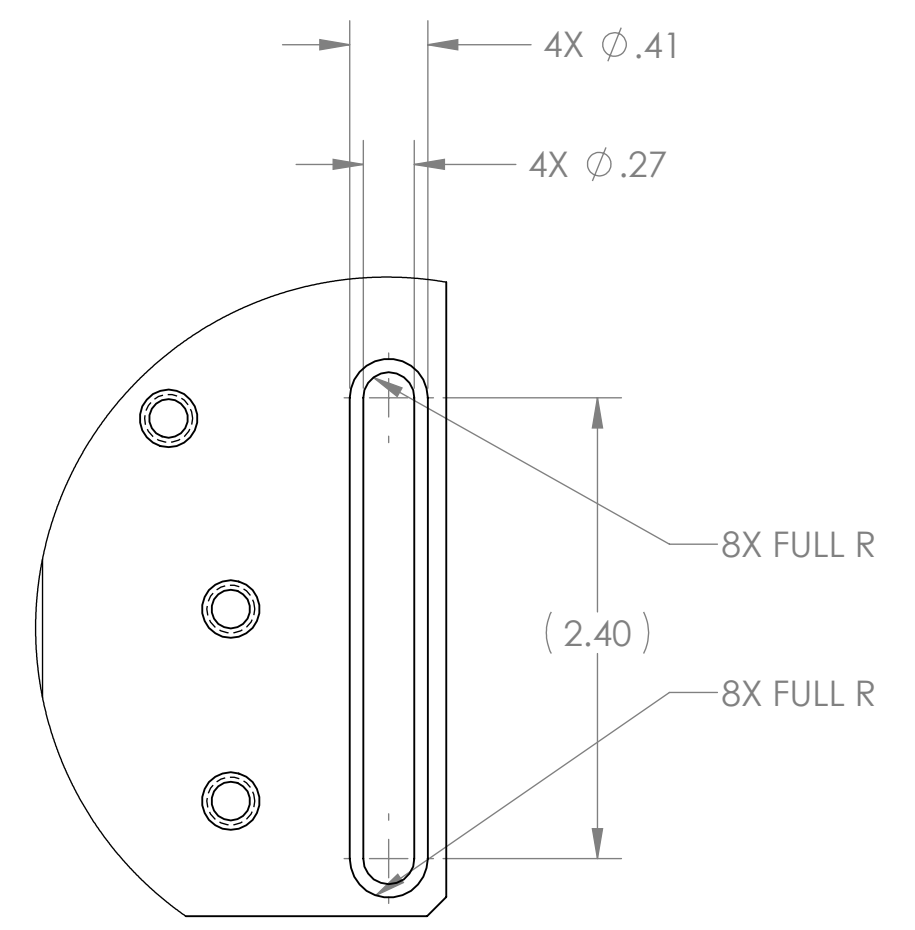
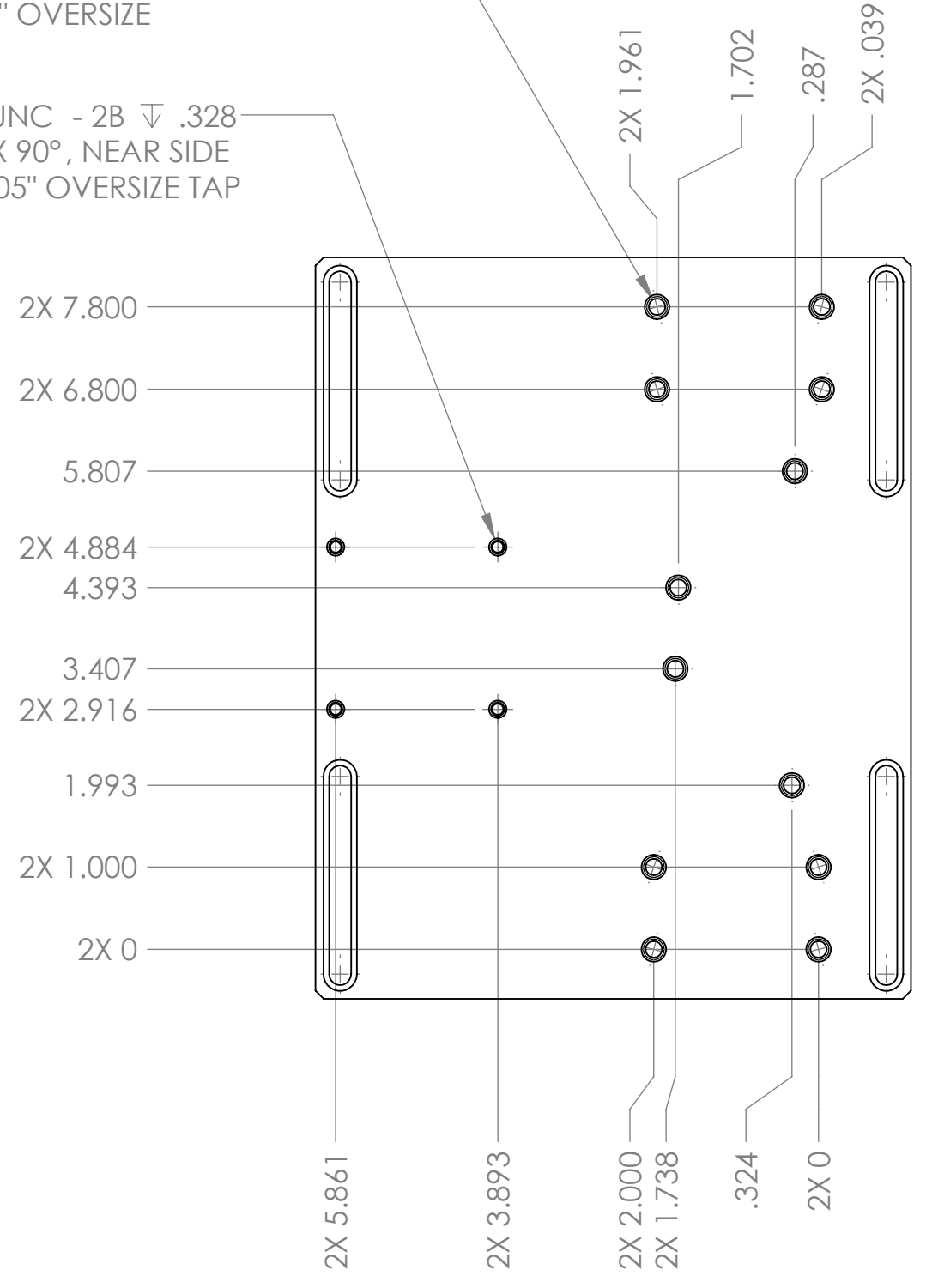

**LIGO** CALIFORNIA INSTITUTE OF TECHNOLOGY  
MASSACHUSETTS INSTITUTE OF TECHNOLOGY

SIZE	DWG. NO.	REV.
B	D1001627	v1
SCALE: 1:2	PROJECTION:	SHEET 2 OF 2

8 7 6 5 4 3 2 1

**NOTES CONTINUED:**  
 5. SCRIBE, ENGRAVE, OR MECHANICALLY STAMP (NO INKS OR DYES) DRAWING PART NUMBER, REVISION (AND VARIANT OR "TYPE" IF APPLICABLE) ON NOTED SURFACE OF PART FOLLOWED ON THE NEXT LINE WITH A THREE DIGIT SERIAL NUMBER. SERIAL NUMBERS START AT 001 FOR THE FIRST ARTICLE AND PROCEED CONSECUTIVELY. USE MINIMUM 0.12" HIGH CHARACTERS, UNLESS THE SIZE OF THE PART DICTATES SMALLER CHARACTERS. A VIBRATORY TOOL MAY BE USED.  
 EXAMPLE: DXXXXXX-VY, TYPE-XX, S/N XXX

REV.	DATE	DCN #	DRAWING TREE #
v1	24 AUG 2010	E100182-v1	-
-	-	-	-
-	-	-	-

D  
C  
B  
A

D  
C  
B  
A

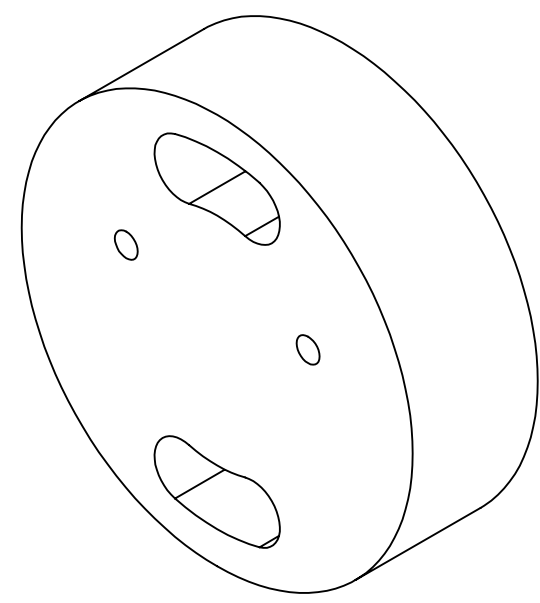
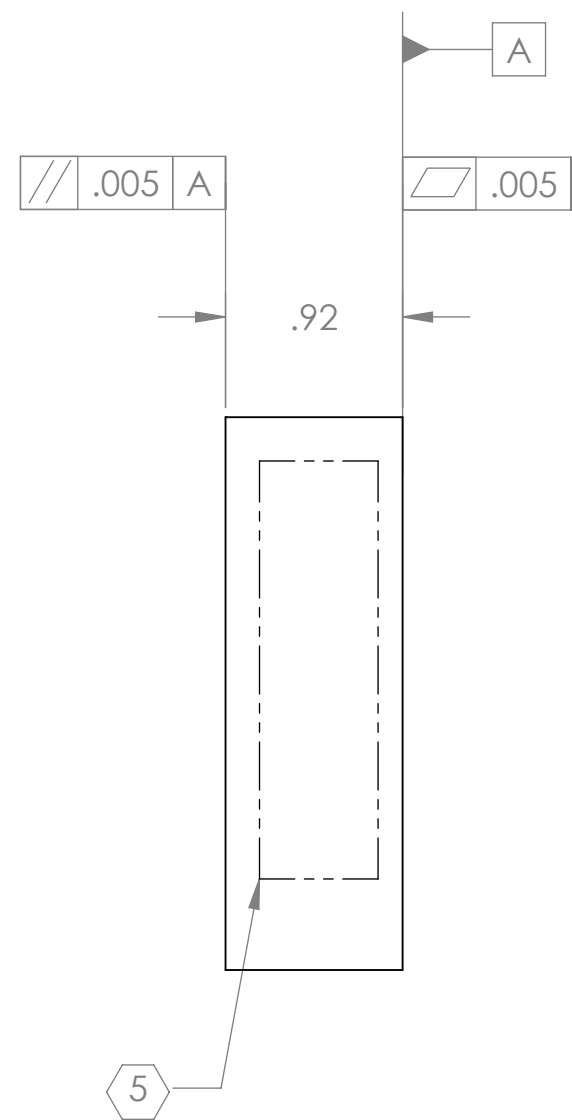
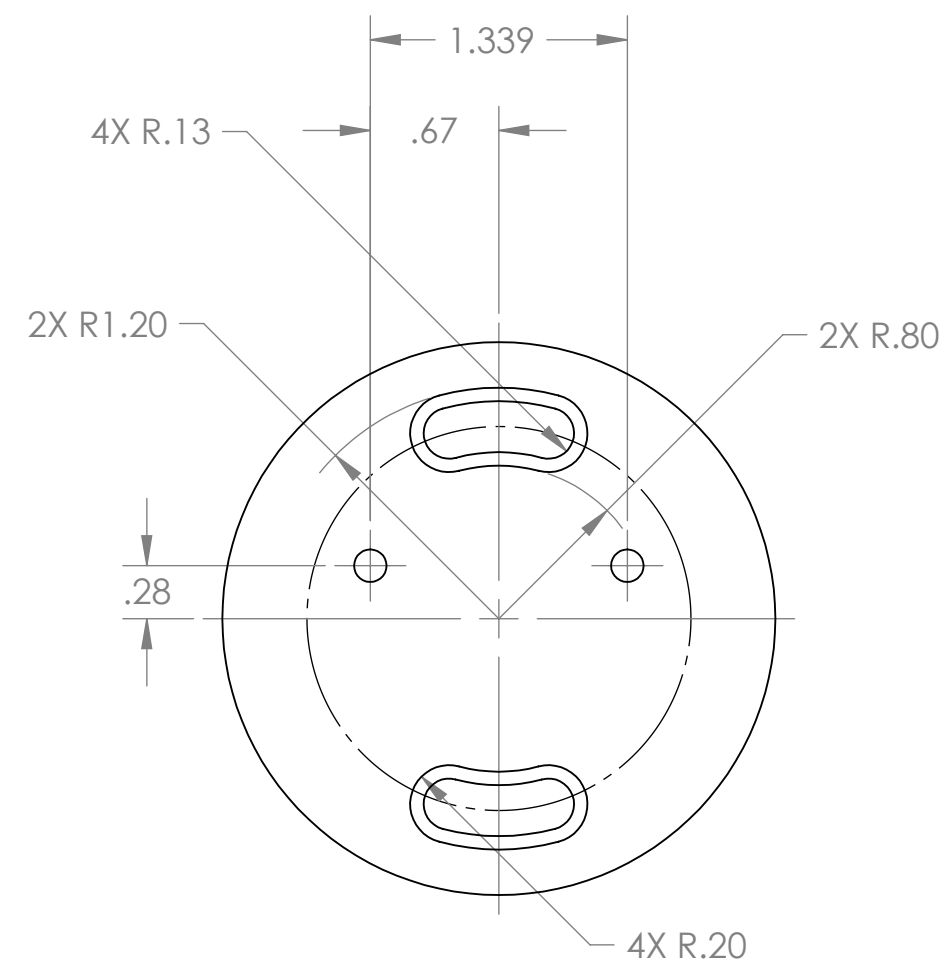

**ISO VIEW**

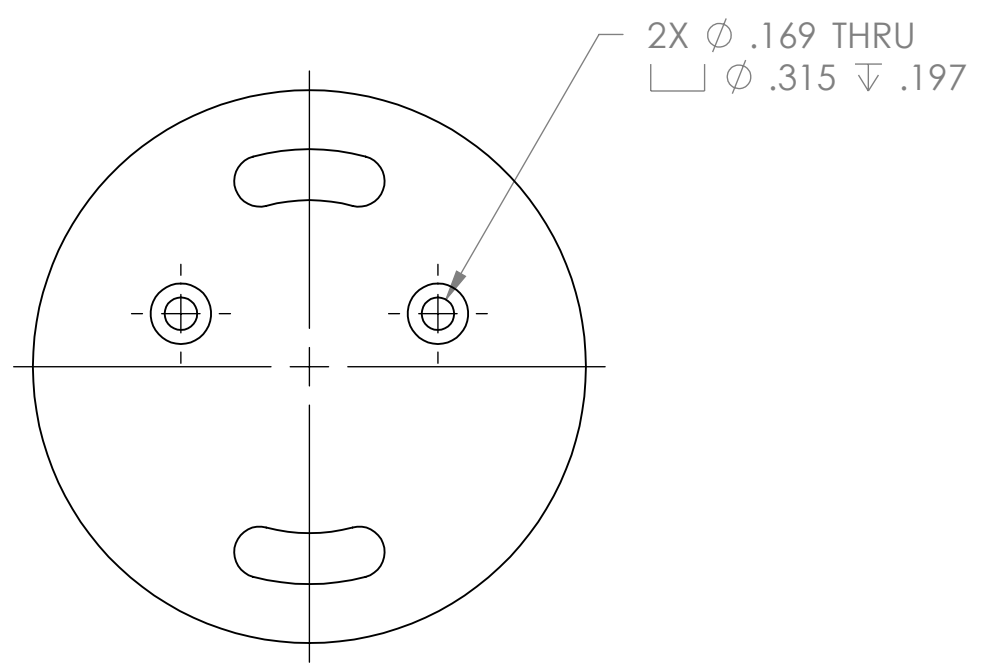

- 8. MACHINE ALL SURFACES TO REMOVE OXIDES AND MILL FINISH, USE OF ABRASIVE TECHNIQUES IS NOT ALLOWED.
- 7. DO NOT USE SANDPAPER, SCOTCH BRITE OR SIMILAR PRODUCTS.
- 6. ALL PARTS SHALL BE MANUFACTURED IN ACCORDANCE WITH LIGO SPECIFICATION E0900364.

NOTES AND TOLERANCES: (UNLESS OTHERWISE SPECIFIED)	
DIMENSIONS ARE IN INCHES	
TOLERANCES: .XX ± .01 .XXX ± .005	
ANGULAR ± 1.0°	
1. INTERPRET DRAWING PER ASME Y14.5-1994. 2. REMOVE ALL SHARP EDGES, R.02 MIN. 3. DO NOT SCALE FROM DRAWING. 4. ALL MACHINING FLUIDS MUST BE FULLY SYNTHETIC, FULLY WATER SOLUBLE AND FREE OF SULFUR, SILICONE, AND CHLORINE.	
MATERIAL	6061-T6 Al
FINISH	N/A μinch

CALIFORNIA INSTITUTE OF TECHNOLOGY MASSACHUSETTS INSTITUTE OF TECHNOLOGY		PART NAME		ALIGO AOS OPLEV MIRROR BASE	
SYSTEM	ADVANCED LIGO	SUB-SYSTEM	AOS	DESIGNER	C. CONLEY 07 MAY 2009
NEXT ASSY	D0900423, D1001611		DRAFTER	N. KILPATRICK 24 AUG 2010	REV.
			CHECKER		v1
			APPROVAL		
			SCALE:	1:1	PROJECTION:
					SHEET 1 OF 1

8 7 6 5 4 3 2 1

D1001628 alIGO AOS Oplev Mirror Base, PART PDM REV: X-004, DRAWING PDM REV: X-004

8 7 6 5 4 3 2 1

**NOTES CONTINUED:**  
 5. SCRIBE, ENGRAVE, OR MECHANICALLY STAMP (NO INKS OR DYES) DRAWING PART NUMBER, REVISION (AND VARIANT OR "TYPE" IF APPLICABLE) ON NOTED SURFACE OF PART FOLLOWED ON THE NEXT LINE WITH A THREE DIGIT SERIAL NUMBER. SERIAL NUMBERS START AT 001 FOR THE FIRST ARTICLE AND PROCEED CONSECUTIVELY. USE MINIMUM 0.12" HIGH CHARACTERS, UNLESS THE SIZE OF THE PART DICTATES SMALLER CHARACTERS. A VIBRATORY TOOL MAY BE USED.  
 EXAMPLE: DXXXXXX-VY, TYPE-XX, S/N XXX

REV.	DATE	DCN #	DRAWING TREE #
v1	22 AUG 2010	E100182-v1	-
-	-	-	-
-	-	-	-

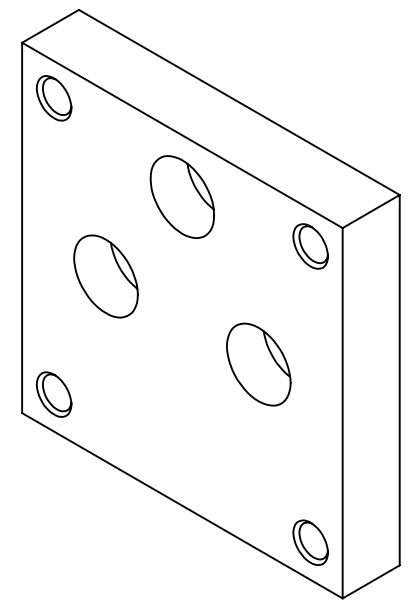

**ISO VIEW**

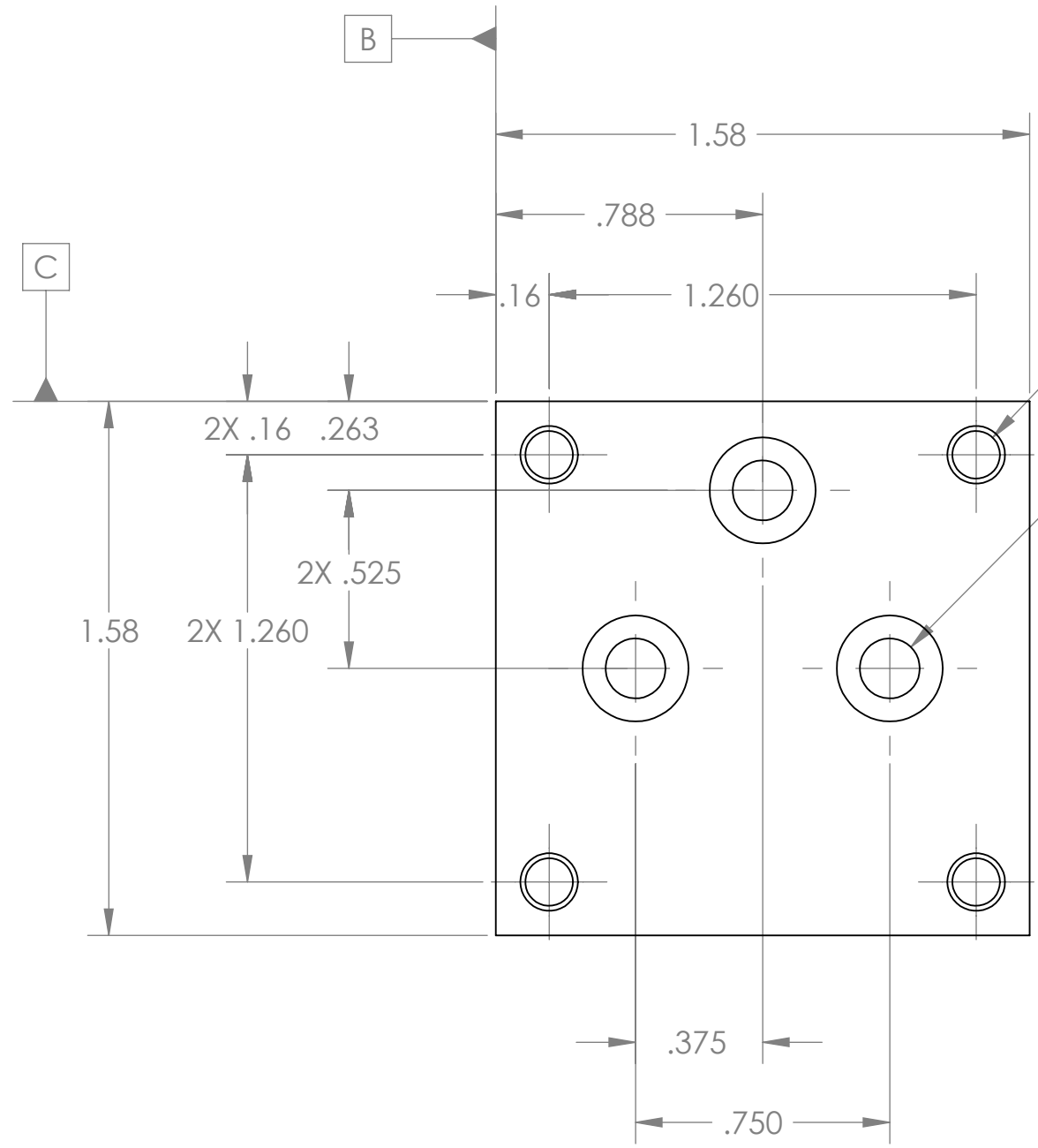

4X  $\phi$  .141 THRU  
 $\surd$   $\phi$  .170 X 90°, NEAR SIDE

3X  $\phi$  .177 THRU  
 $\sqsubset$   $\phi$  .313  $\nabla$  .179

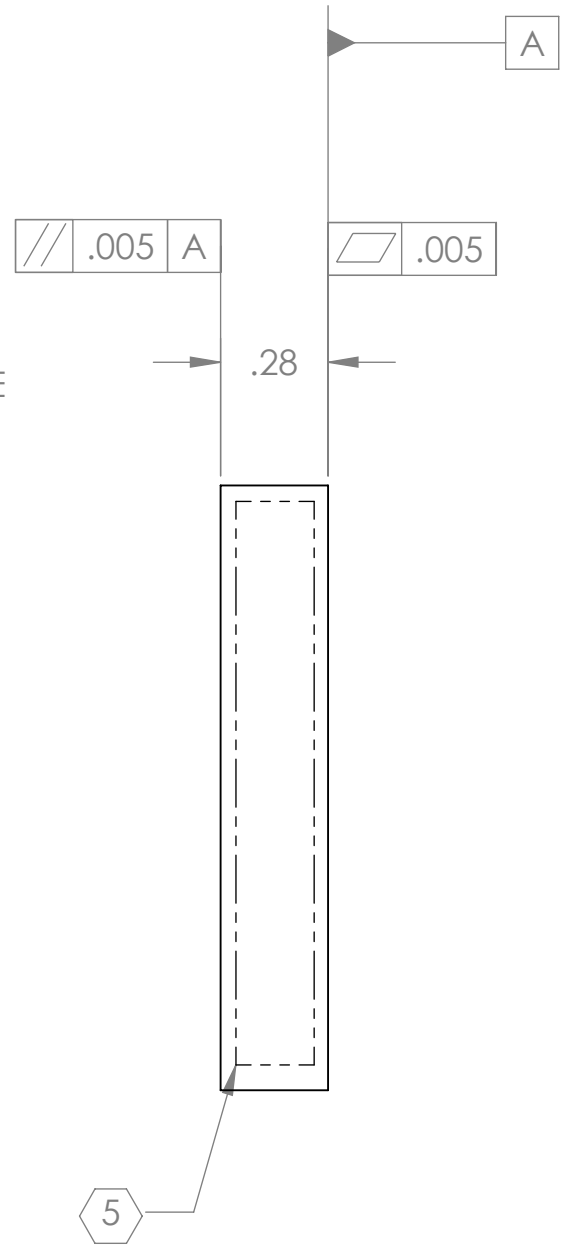

- 8. MACHINE ALL SURFACES TO REMOVE OXIDES AND MILL FINISH, USE OF ABRASIVE TECHNIQUES IS NOT ALLOWED.
- 7. DO NOT USE SANDPAPER, SCOTCH BRITE OR SIMILAR PRODUCTS.
- 6. ALL PART SHALL BE MANUFACTURED IN ACCORDANCE WITH LIGO SPECIFICATION E0900364.

NOTES AND TOLERANCES: (UNLESS OTHERWISE SPECIFIED)	
DIMENSIONS ARE IN INCHES	
TOLERANCES: .XX $\pm$ .01 .XXX $\pm$ .005 ANGULAR $\pm$ 1.0°	
1. INTERPRET DRAWING PER ASME Y14.5-1994.	2. REMOVE ALL SHARP EDGES, R.02 MIN.
3. DO NOT SCALE FROM DRAWING.	
4. ALL MACHINING FLUIDS MUST BE FULLY SYNTHETIC, FULLY WATER SOLUBLE AND FREE OF SULFUR, SILICONE, AND CHLORINE.	
MATERIAL	FINISH
6061-T6 Al	N/A $\mu$ inch

CALIFORNIA INSTITUTE OF TECHNOLOGY MASSACHUSETTS INSTITUTE OF TECHNOLOGY		PART NAME		ALIGO AOS OPLEV TELESCOPE MOUNT BASE	
SYSTEM	ADVANCED LIGO	SUB-SYSTEM	AOS	DESIGNER	C. CONLEY 25 JUN 2010
DRAFTER	N. KILPATRICK 22 AUG 2010	CHECKER		APPROVAL	
SIZE	B	DWG. NO.	D1001646	REV.	v1
SCALE:	2:1	PROJECTION:		SHEET 1 OF 1	

D1001646 ALIGO AOS Oplev Telescope Mount Base, PART PDM REV: X-006, DRAWING PDM REV: X-005

8 7 6 5 4 3 2 1

NOTES CONTINUED:  
 5. SCRIBE, ENGRAVE, OR MECHANICALLY STAMP (NO INKS OR DYES) DRAWING PART NUMBER, REVISION (AND VARIANT OR "TYPE" IF APPLICABLE) ON NOTED SURFACE OF PART FOLLOWED ON THE NEXT LINE WITH A THREE DIGIT SERIAL NUMBER. SERIAL NUMBERS START AT 001 FOR THE FIRST ARTICLE AND PROCEED CONSECUTIVELY. USE MINIMUM 0.12" HIGH CHARACTERS, UNLESS THE SIZE OF THE PART DICTATES SMALLER CHARACTERS. A VIBRATORY TOOL MAY BE USED.  
 EXAMPLE: DXXXXXX-VY, TYPE-XX, S/N XXX

REV.	DATE	DCN #	DRAWING TREE #
v1	22 AUG 2010	E100182-v1	-
-	-	-	-
-	-	-	-

D  
C  
B  
A

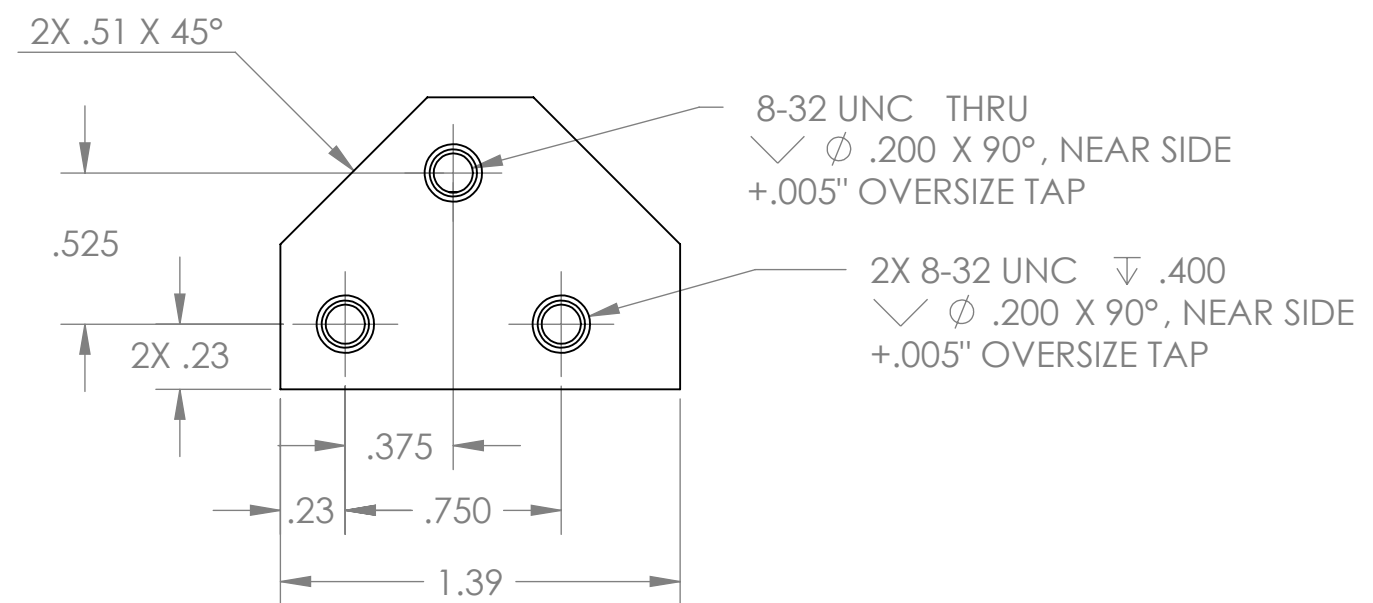
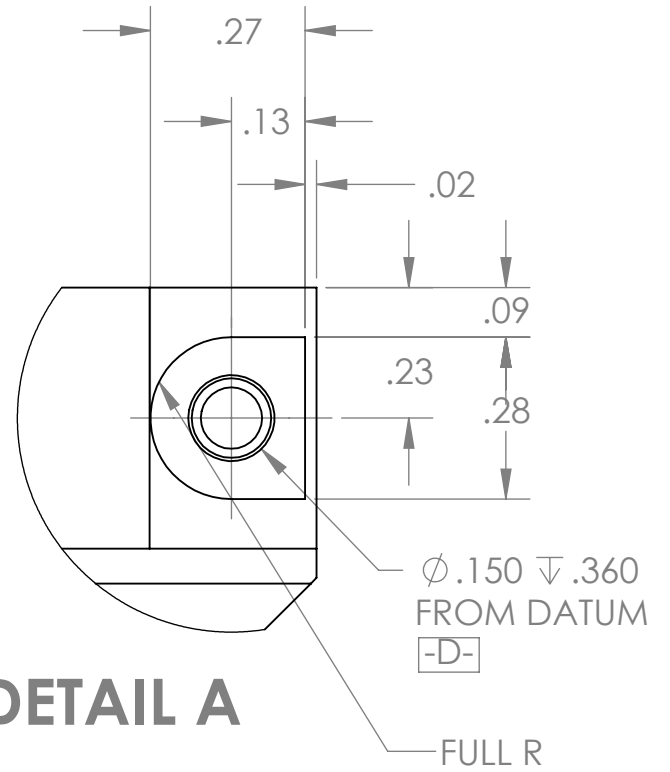
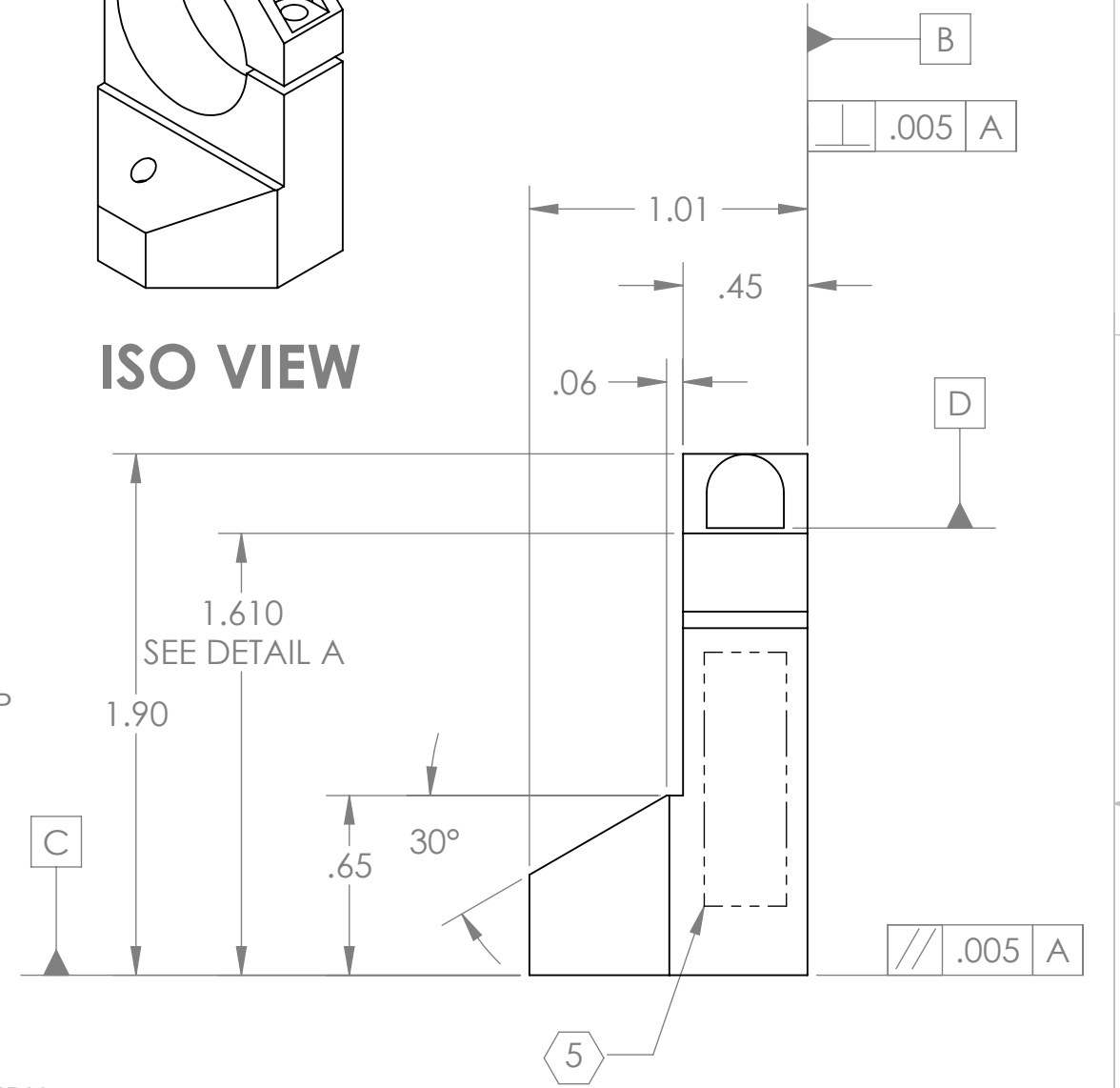
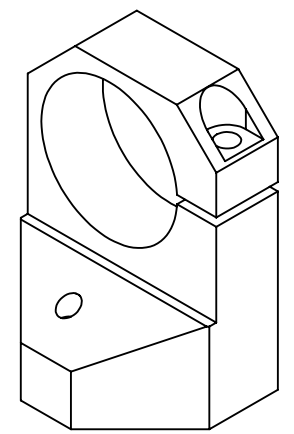
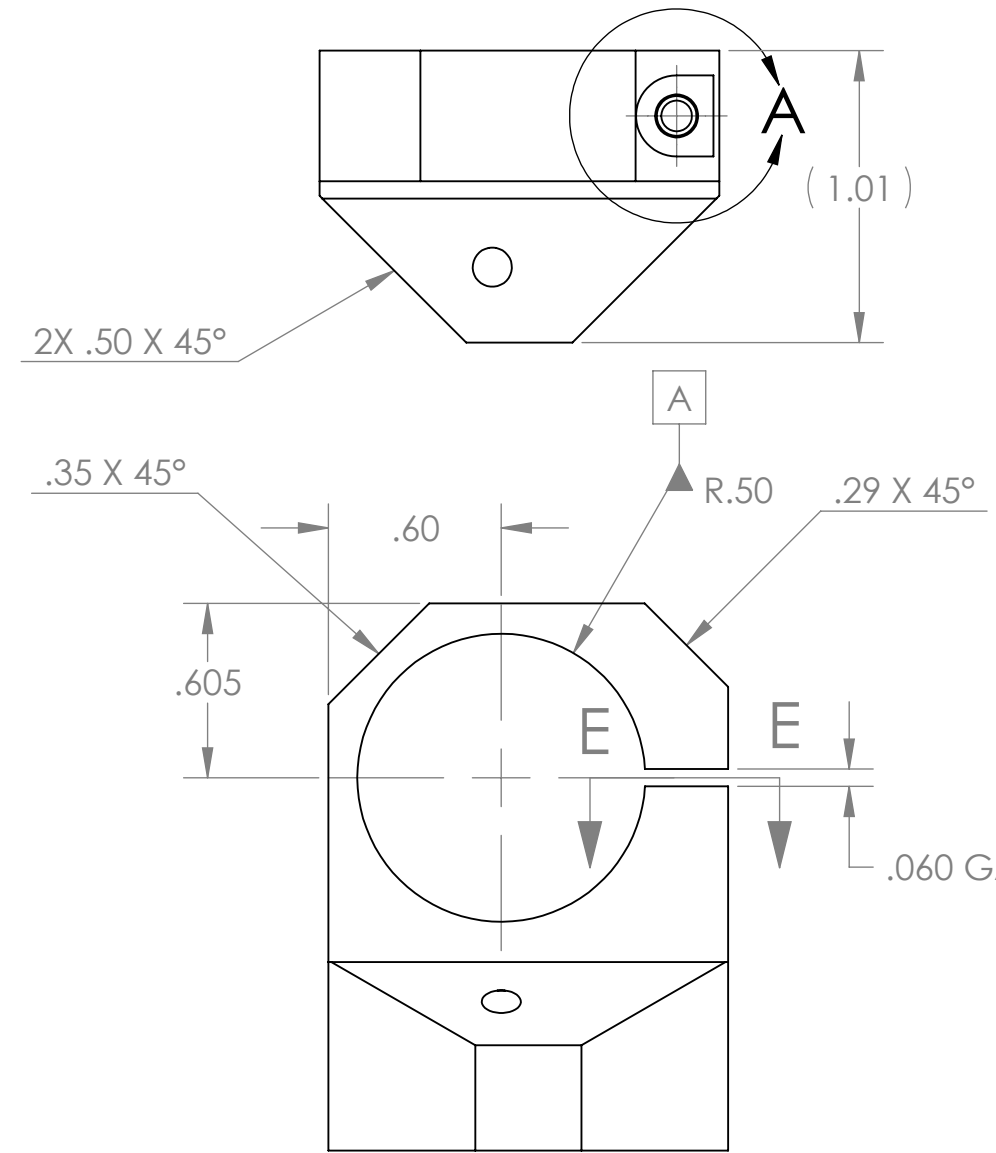
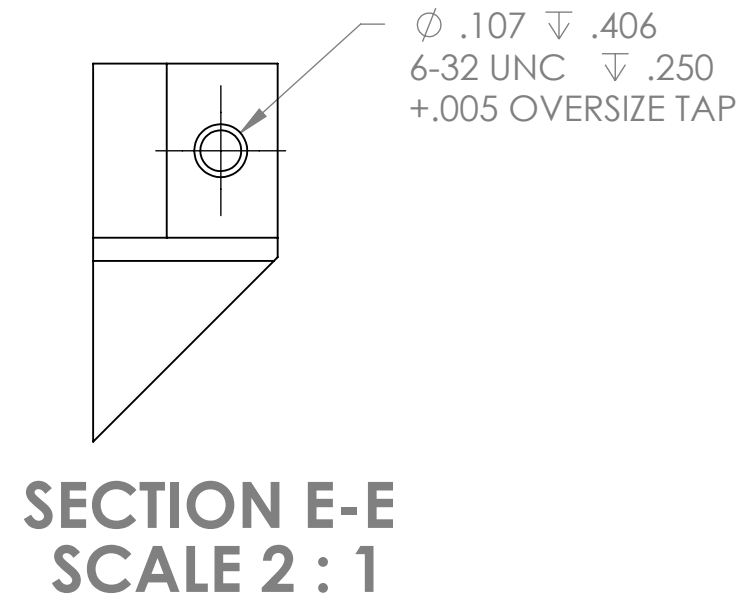

- MACHINE ALL SURFACES TO REMOVE OXIDES AND MILL FINISH, USE OF ABRASIVE TECHNIQUES IS NOT ALLOWED.
- DO NOT USE SANDPAPER SCOTCH BRITE OR SIMILAR PRODUCTS.
- ALL PARTS SHALL BE MANUFACTURED IN ACCORDANCE WITH LIGO SPECIFICATION E0900364.

DIMENSIONS ARE IN INCHES		TOLERANCES:		ANGULAR $\pm 1.0^\circ$		MATERIAL		FINISH		NOTES AND TOLERANCES: (UNLESS OTHERWISE SPECIFIED)		PART NAME		REV.			
.XX	$\pm .01$	.XXX	$\pm .005$			6061-T6 Al	N/A	$\mu$ inch			1. INTERPRET DRAWING PER ASME Y14.5-1994. 2. REMOVE ALL SHARP EDGES, R.02 MIN. 3. DO NOT SCALE FROM DRAWING. 4. ALL MACHINING FLUIDS MUST BE FULLY SYNTHETIC, FULLY WATER SOLUBLE AND FREE OF SULFUR, SILICONE, AND CHLORINE.	ALIGO AOS OPLEV TELESCOPE MOUNT BASE		v1			
										CALIFORNIA INSTITUTE OF TECHNOLOGY MASSACHUSETTS INSTITUTE OF TECHNOLOGY		DESIGNER C. CONLEY 25 JUN 2010		SIZE DWG. NO. B D1001647			
										ADVANCED LIGO		SUB-SYSTEM AOS		DRAFTER N. KILPATRICK 22 AUG 2010		SCALE: 3:2	
										NEXT ASSY D1001291		CHECKER		PROJECTION:		SHEET 1 OF 1	
										APPROVAL							

D1001647 alIGO AOS Oplev Telescope Clamp, PART PDM REV: X-009, DRAWING PDM REV: X-004

8 7 6 5 4 3 2 1

NOTES CONTINUED:  
 ⑤ SCRIBE, ENGRAVE, OR MECHANICALLY STAMP (NO INKS OR DYES) DRAWING PART NUMBER, REVISION (AND VARIANT OR TYPE IF APPLICABLE) ON NOTED SURFACE OF PART FOLLOWED ON THE NEXT LINE WITH A THREE DIGIT SERIAL NUMBER. SERIAL NUMBERS START AT 001 FOR THE FIRST ARTICLE AND PROCEED CONSECUTIVELY. USE MINIMUM 0.12" HIGH CHARACTERS, UNLESS THE SIZE OF THE PART DICTATES SMALLER CHARACTERS. A VIBRATORY TOOL MAY BE USED. EXAMPLE: DXXXXXX-VY, TYPE-XX, S/N XXX

REV.	DATE	DCN #	DRAWING TREE #
v1	26 JULY 2010	E1000182-v1	-
-	-	-	-
-	-	-	-

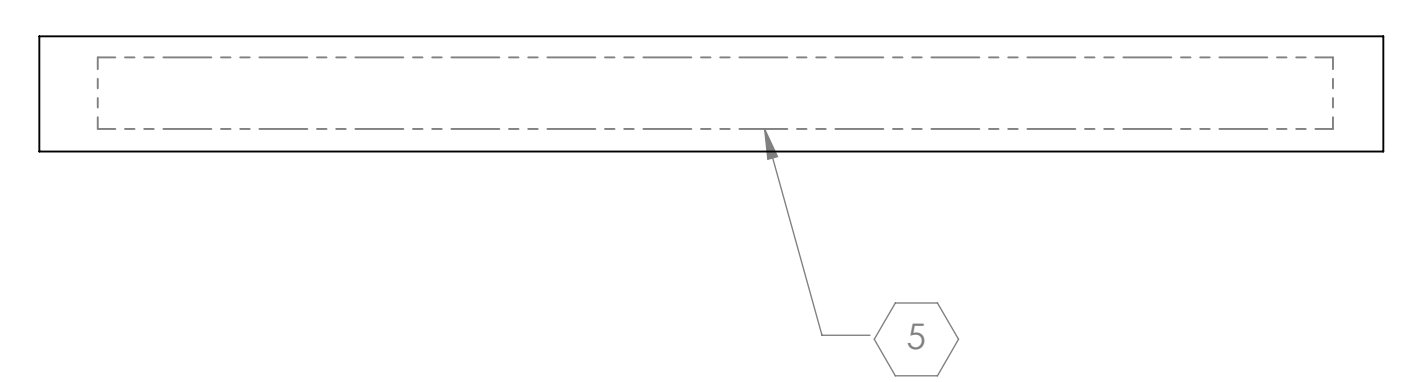
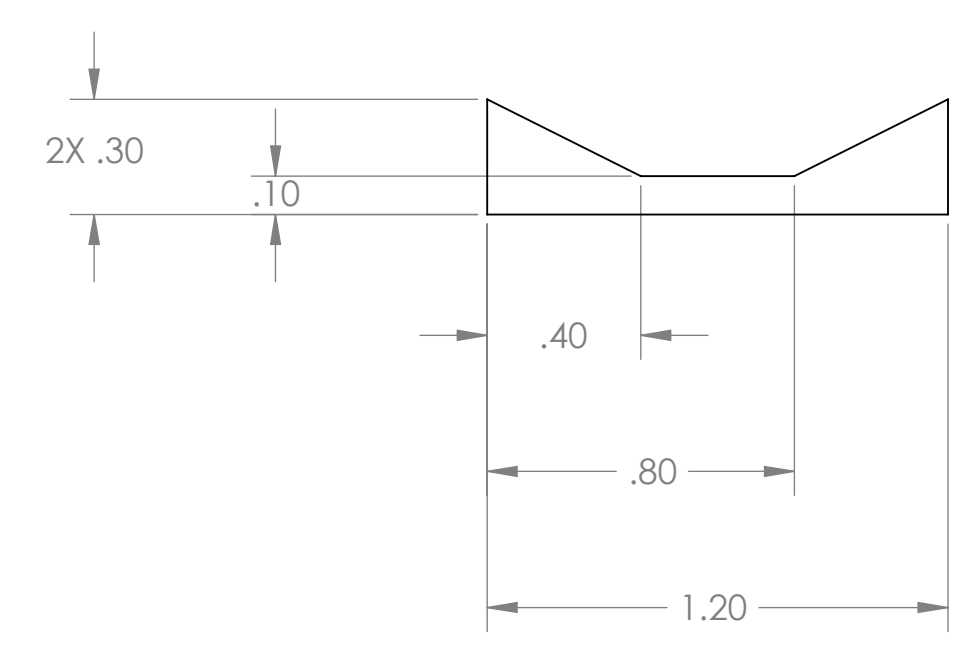
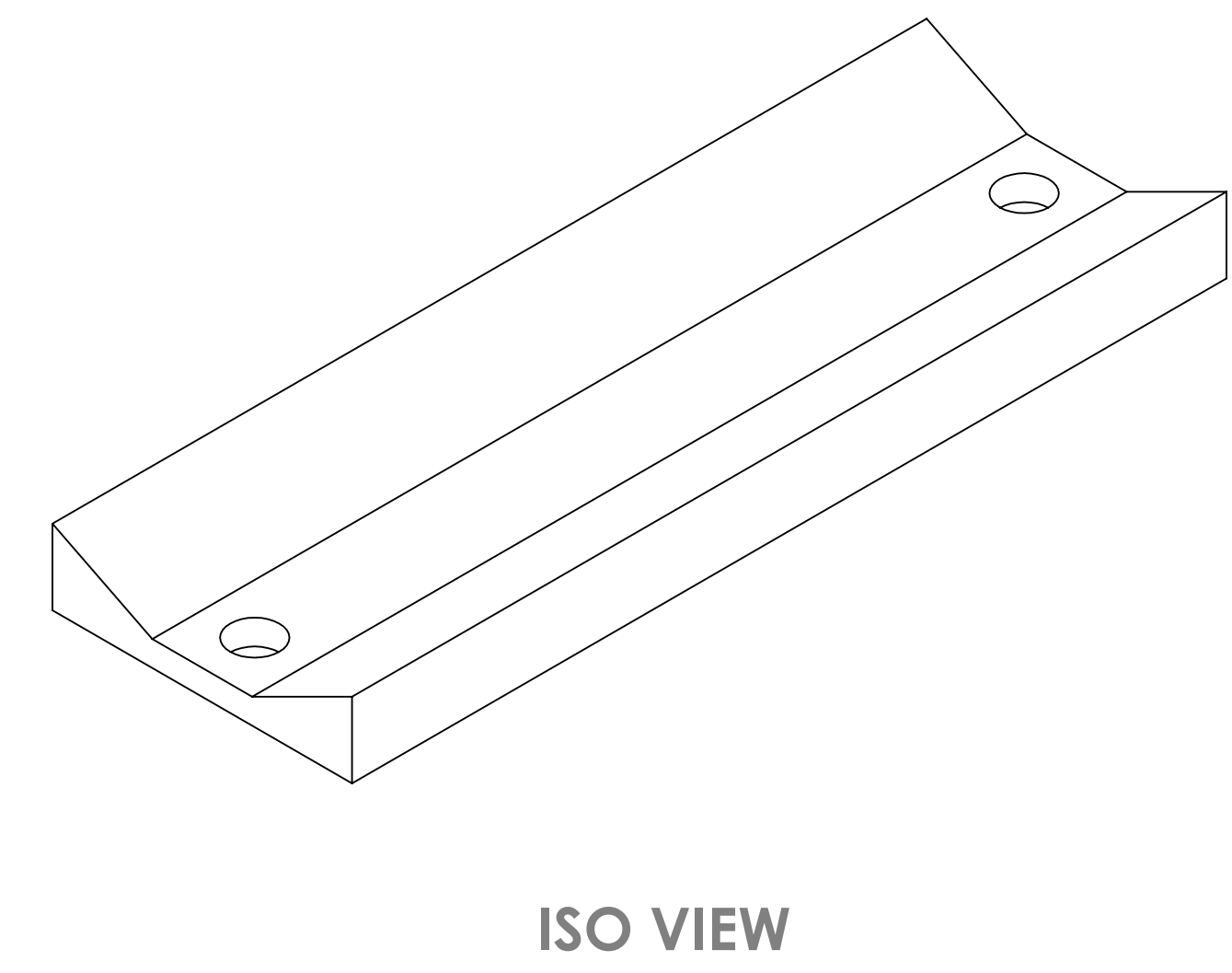
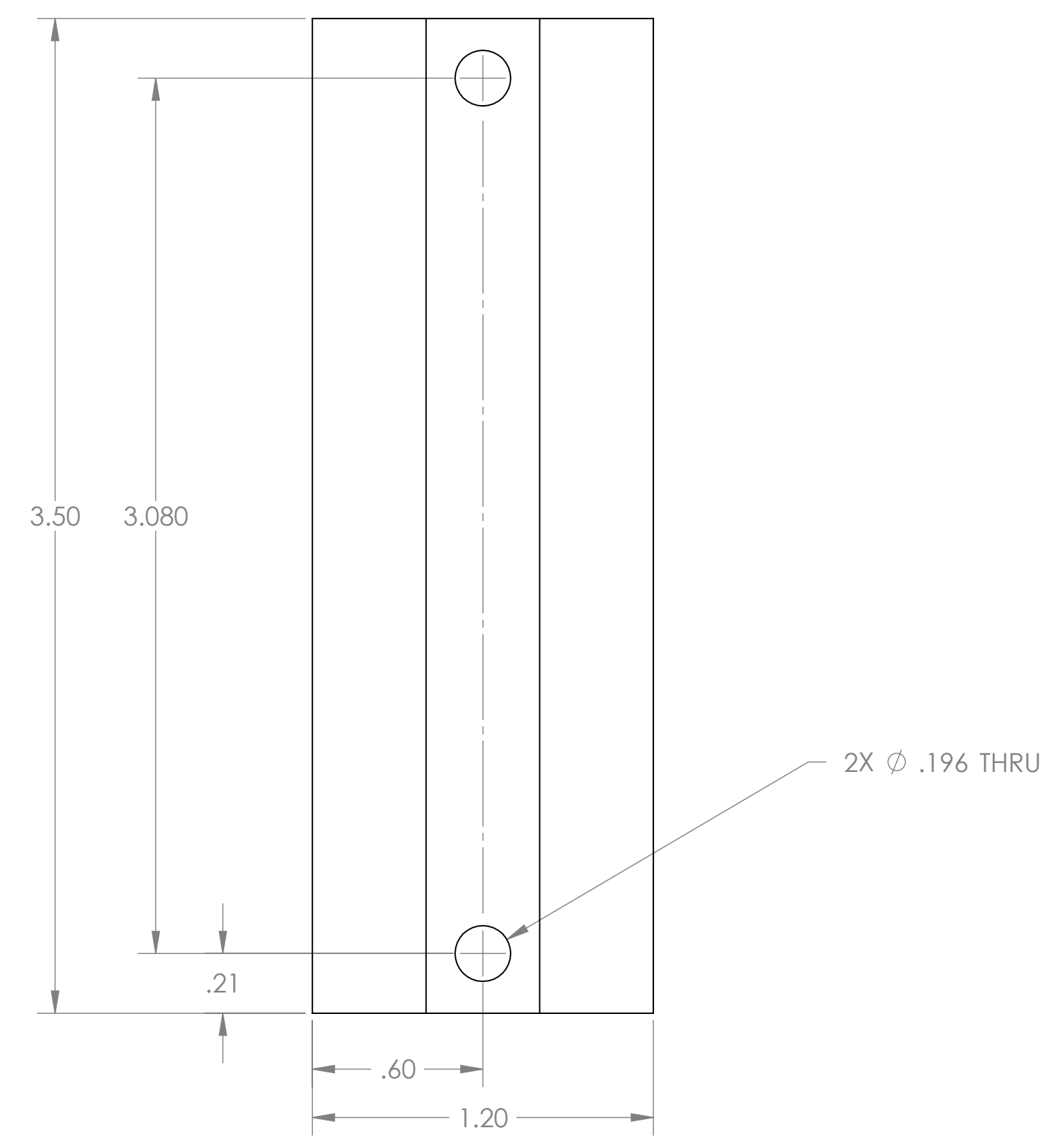

NOTES AND TOLERANCES: (UNLESS OTHERWISE SPECIFIED)				LIGO CALIFORNIA INSTITUTE OF TECHNOLOGY MASSACHUSETTS INSTITUTE OF TECHNOLOGY		PART NAME	
DIMENSIONS ARE IN INCHES TOLERANCES: .XX ± .01 .XXX ± .005 ANGULAR ± 1.0°				1. INTERPRET DRAWING PER ASME Y14.5-1994. 2. REMOVE ALL SHARP EDGES, R.02 MIN. 3. DO NOT SCALE FROM DRAWING. 4. ALL MACHINING FLUIDS MUST BE FULLY SYNTHETIC, FULLY WATER SOLUBLE AND FREE OF SULFUR, SILICONE, AND CHLORINE.		<b>ALIGO AOS OPLEV AUXILIARY VIEW FINDER TELESCOPE MOUNT</b>	
<b>MATERIAL</b> 6061-T6 Al		<b>FINISH</b> 63 μinch		<b>SYSTEM</b> ADVANCED LIGO		<b>SUB-SYSTEM</b> AOS	
<b>NEXT ASSY</b> D1000308				<b>DESIGNER</b> N. KILPATRICK		<b>DATE</b> 26 JULY 2010	
				<b>CHECKER</b> N. KILPATRICK		<b>SIZE</b> D	
				<b>APPROVAL</b>		<b>DWG. NO.</b> D1001670	
				<b>SCALE:</b> 2:1		<b>PROJECTION:</b>	
						<b>REV.</b> v1	
						SHEET 1 OF 1	

D:\001\670\aligo\_aos\_oplev\_view\_finder\_telescope\_mount.pprt.pdm REV: X.014, DRAWING PDM REV: X.015

NOTES CONTINUED:  
 ⑤ SCRIBE, ENGRAVE, OR MECHANICALLY STAMP (NO INKS OR DYES) DRAWING PART NUMBER, REVISION (AND VARIANT OR TYPE IF APPLICABLE) ON NOTED SURFACE OF PART FOLLOWED ON THE NEXT LINE WITH A THREE DIGIT SERIAL NUMBER. SERIAL NUMBERS START AT 001 FOR THE FIRST ARTICLE AND PROCEED CONSECUTIVELY. USE MINIMUM 0.12" HIGH CHARACTERS, UNLESS THE SIZE OF THE PART DICTATES SMALLER CHARACTERS. A VIBRATORY TOOL MAY BE USED. EXAMPLE: DXXXXXX-VY, TYPE-XX, S/N XXX

REV.	DATE	DCN #	DRAWING TREE #
v1	05 AUGUST 2010	E1000182-V1	-
-	-	-	-
-	-	-	-

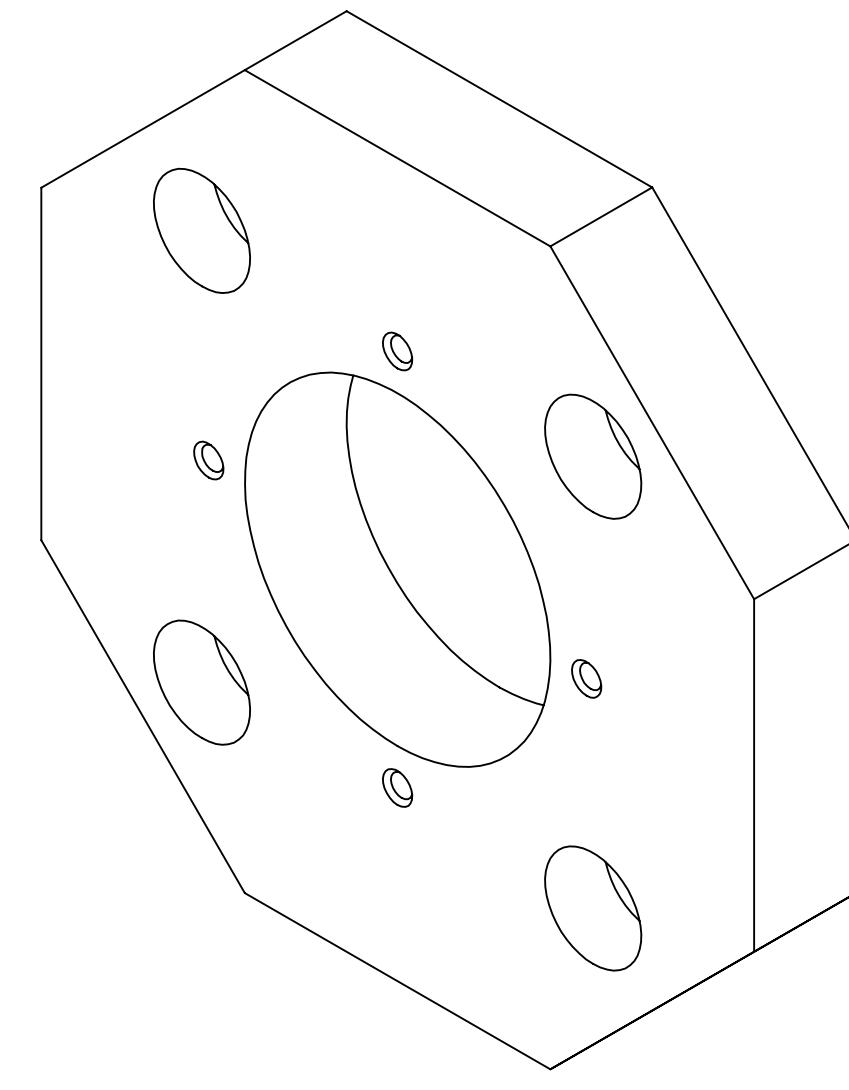

ISO VIEW

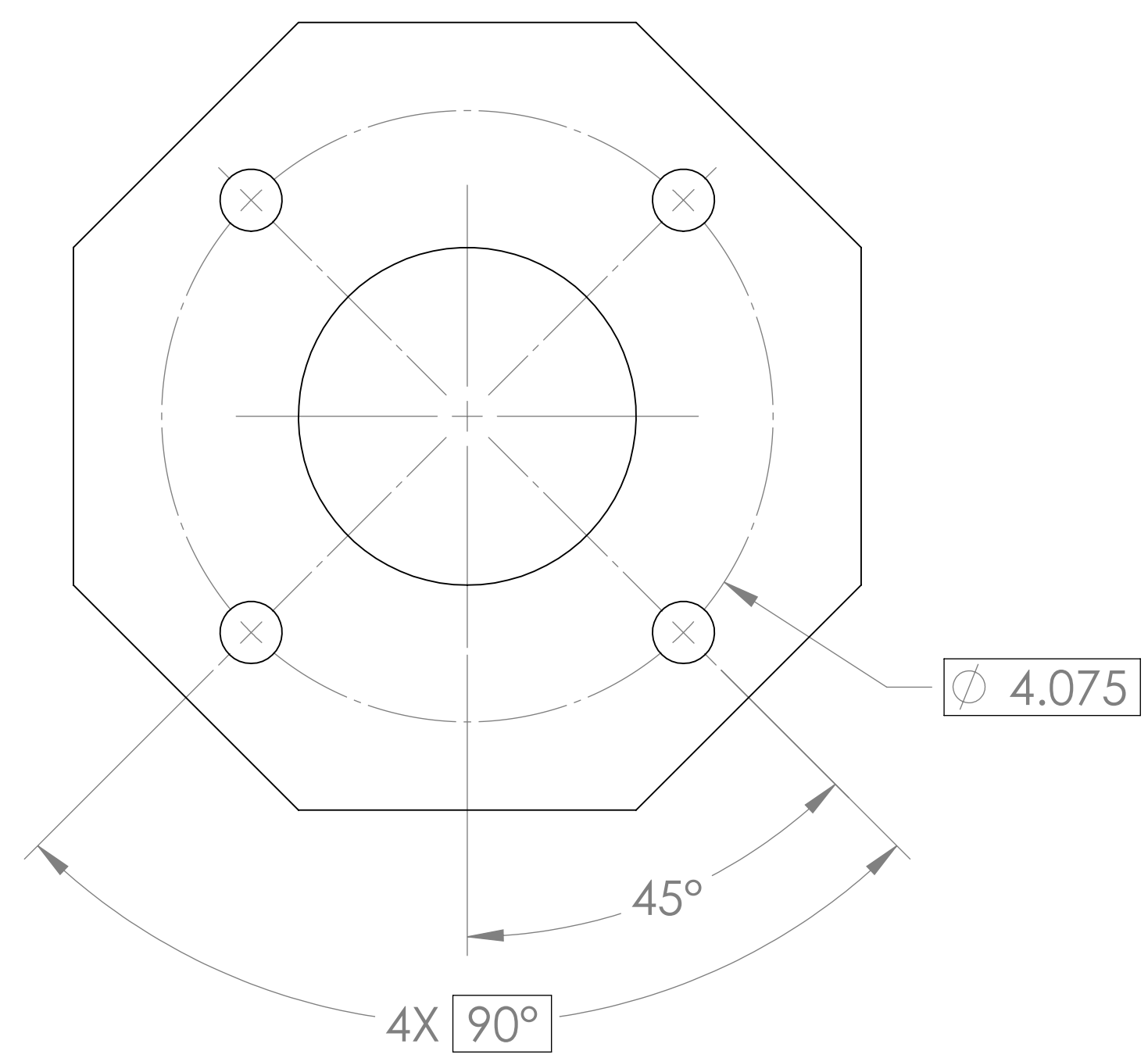
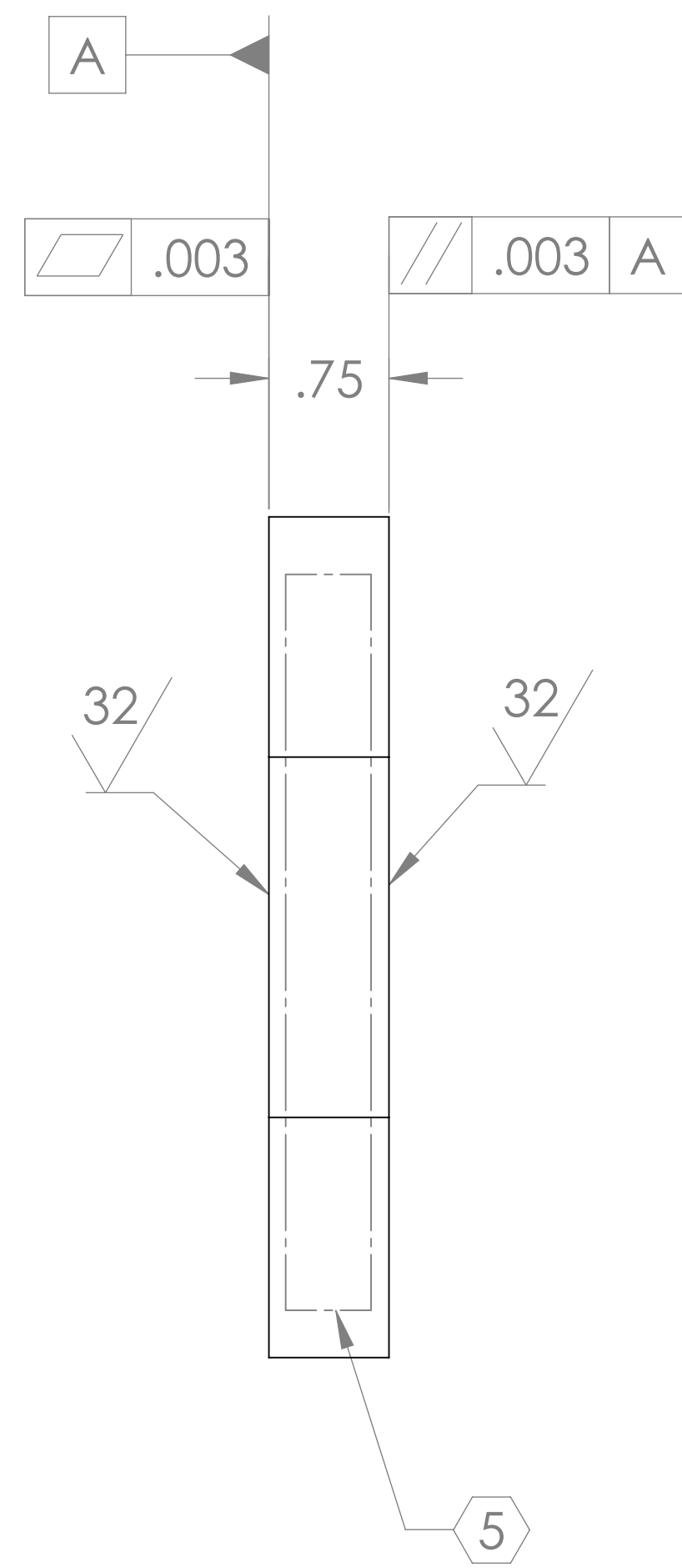
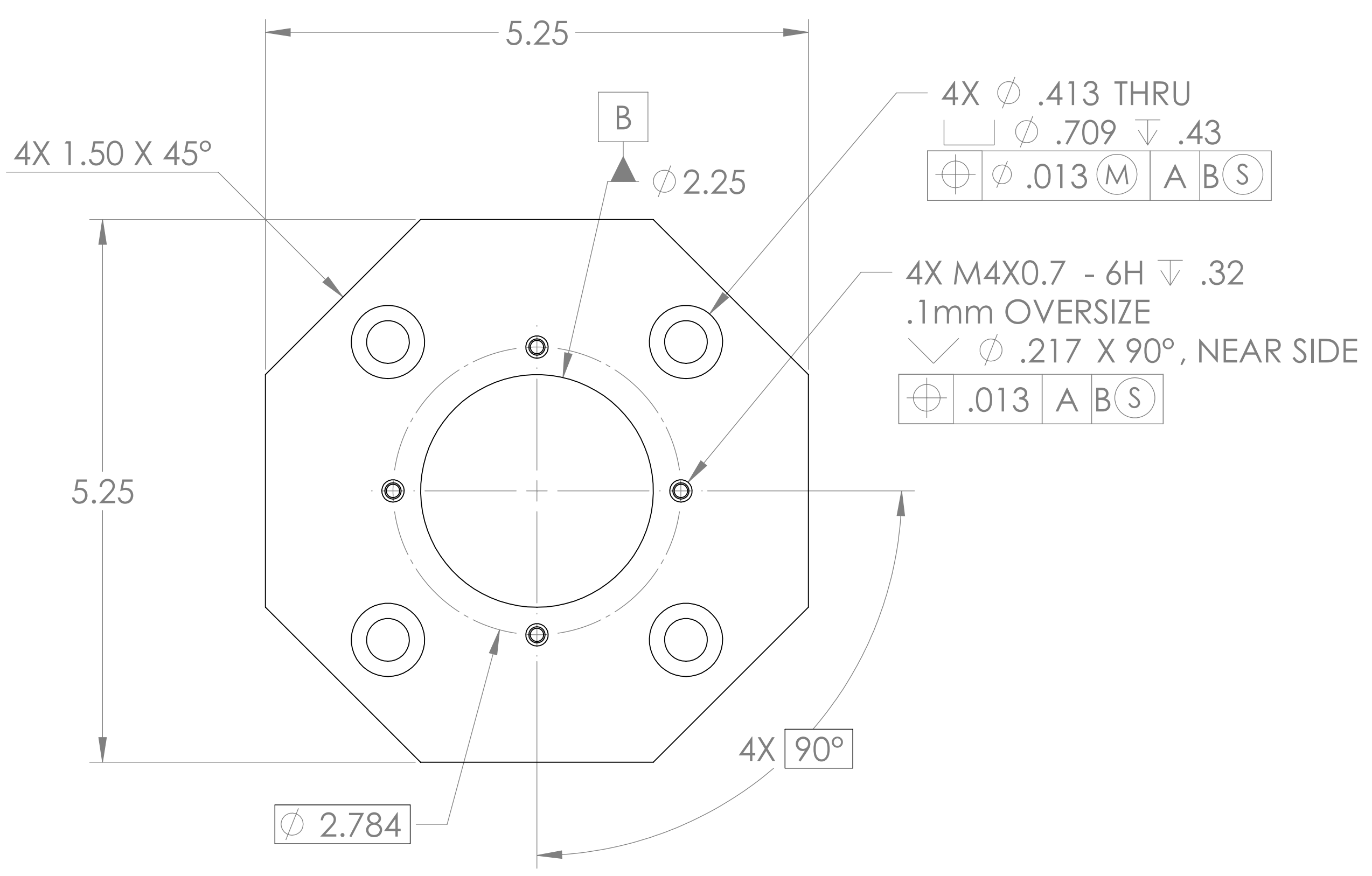

DIMENSIONS ARE IN INCHES		NOTES AND TOLERANCES: (UNLESS OTHERWISE SPECIFIED)		CALIFORNIA INSTITUTE OF TECHNOLOGY MASSACHUSETTS INSTITUTE OF TECHNOLOGY		PART NAME	
TOLERANCES: .XX $\pm$ .01 .XXX $\pm$ .005		1. INTERPRET DRAWING PER ASME Y14.5-1994. 2. REMOVE ALL SHARP EDGES, R.02 MIN. 3. DO NOT SCALE FROM DRAWING. 4. ALL MACHINING FLUIDS MUST BE FULLY SYNTHETIC, FULLY WATER SOLUBLE AND FREE OF SULFUR, SILICONE, AND CHLORINE.		SYSTEM <b>ADVANCED LIGO</b>		SUB-SYSTEM <b>AOS</b>	
ANGULAR $\pm$ 1.0°		MATERIAL		NEXT ASSY		DESIGNER C. CONLEY 05 MAR 2009	
		304 SSSL		63 $\mu$ inch		DWG. NO. <b>D1001993</b>	
				D1001334		CHECKER N. KILPATRICK 03 JUNE 2010	
						APPROVAL SCALE: 1:1 PROJECTION:	
						REV. v1	
						SHEET 1 OF 1	

D1001993.dwg AOS Oplev TX Mounting Plate (PR3, SR3). PART PDM REV: X-207. DRAWING PDM REV: X-006