

PROPRIETARY AND CONFIDENTIAL
 THE INFORMATION CONTAINED IN THIS
 DRAWING IS THE SOLE PROPERTY OF
 GNB CORPORATION. ANY
 REPRODUCTION IN PART OR AS A WHOLE
 WITHOUT THE WRITTEN PERMISSION OF
 GNB CORPORATION IS PROHIBITED.

REVISIONS				
ZONE	REV.	DESCRIPTION	DATE	APPROVED

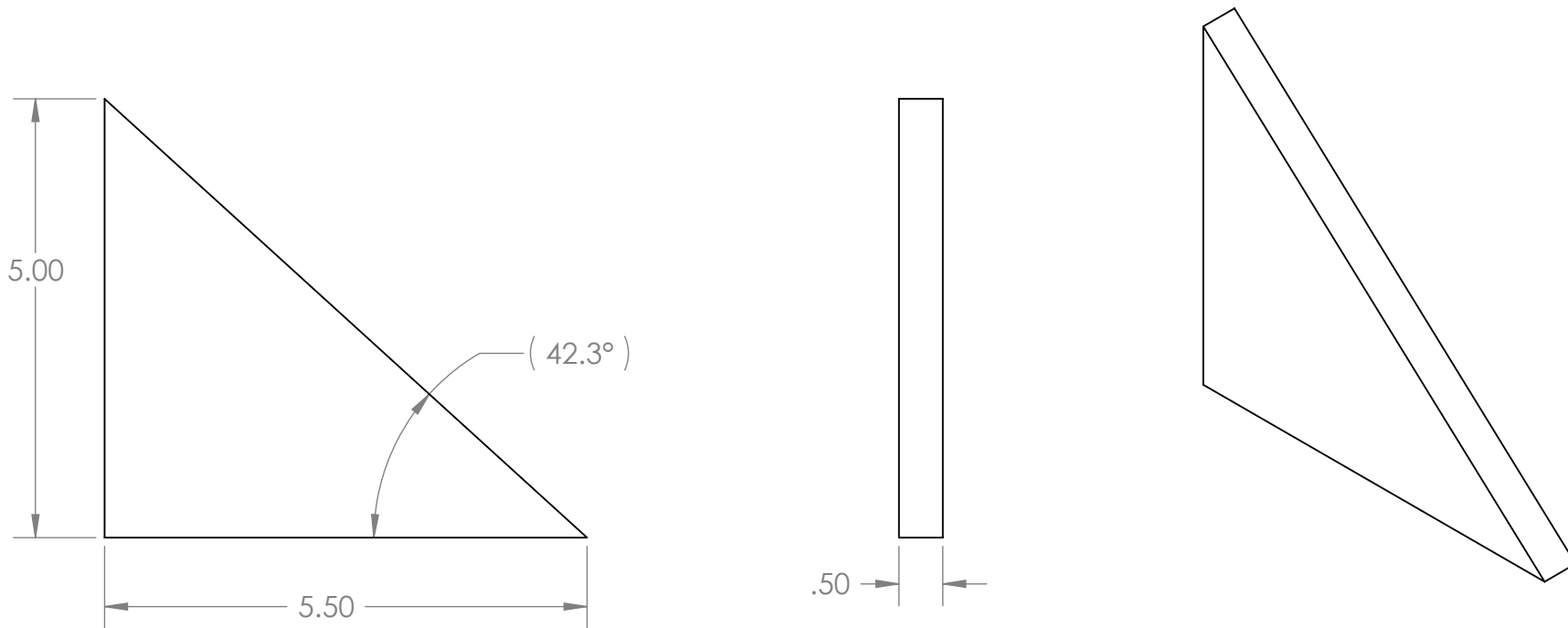

NOTES:

1. THE FOLLOWING ARE NOT ALLOWED: GRINDING, HONING, LAPPING, POLISHING, BUFFING, SANDING, BLASTING.
2. NO HYDROCARBONS ALLOWED IN THE COOLANT. COOLANT LIMITS AS FOLLOWS
 - a. WATER LEACHABLE CHLORIDES: 100PPM
 - b. TOTAL HALOGENS (INCLUDING CHLORIDES): 1000PPM
 - c. TOTAL SULFUR: 1000PPM
3. DO NOT ALLOW PART TO BE CONTAMINATED BY CARBON STEEL OR IRON CONTACT.
4. MACHINING TO BE IN LINE WITH LIGO SPECIFICATION E0900406, LATEST REVISION.

DESCRIPTION: PLT, .50 THK, 5.00 WD, 5.50 LG		<p>SCIENTIFIC AND INDUSTRIAL EQUIPMENT</p> <p>3200 DWIGHT RD, SUITE 100 ELK GROVE, CA 95758 916-395-3003 FAX: 916-395-3363 WWW.GNBVALVES.COM</p>															
MATERIAL: AISI 304/AISI 304L DUAL CERT PER SA 240																	
UNLESS OTHERWISE SPECIFIED:	WEIGHT: 1.99 #	<table border="1"> <tr> <th colspan="3">APPROVALS</th> </tr> <tr> <th>NAME</th> <th colspan="2">DATE</th> </tr> <tr> <td>DRAFTER MKM2</td> <td colspan="2">7/21/10</td> </tr> <tr> <td>CHECKER</td> <td colspan="2"></td> </tr> <tr> <td>ENGINEER MKM2</td> <td colspan="2">7/21/10</td> </tr> </table>	APPROVALS			NAME	DATE		DRAFTER MKM2	7/21/10		CHECKER			ENGINEER MKM2	7/21/10	
APPROVALS																	
NAME	DATE																
DRAFTER MKM2	7/21/10																
CHECKER																	
ENGINEER MKM2	7/21/10																
DIMENSIONS ARE IN INCHES	FINISH 125																
TOLERANCES:																	
ANGULAR: ± 0°30'																	
.XX ± .03																	
.XXX ± .005																	
UNSPECIFIED FILLETS: R.015																	
BREAK EDGES .010 x 45°																	
REMOVE ALL BURRS																	
// ◻ ⊥ WITHIN .03																	
THIRD ANGLE PROJECTION																	
DO NOT SCALE DRAWING		<p>TITLE: PLATE, BRACKET, BRACE</p> <p>DWG. NO. A 114427-00S</p> <p>SCALE: 1:2 SHEET 1 OF 1</p>															