

PROPRIETARY AND CONFIDENTIAL
 THE INFORMATION CONTAINED IN THIS
 DRAWING IS THE SOLE PROPERTY OF
 GNB CORPORATION. ANY
 REPRODUCTION IN PART OR AS A WHOLE
 WITHOUT THE WRITTEN PERMISSION OF
 GNB CORPORATION IS PROHIBITED.

ZONE		REV.	DESCRIPTION	REVISIONS		DATE	APPROVED

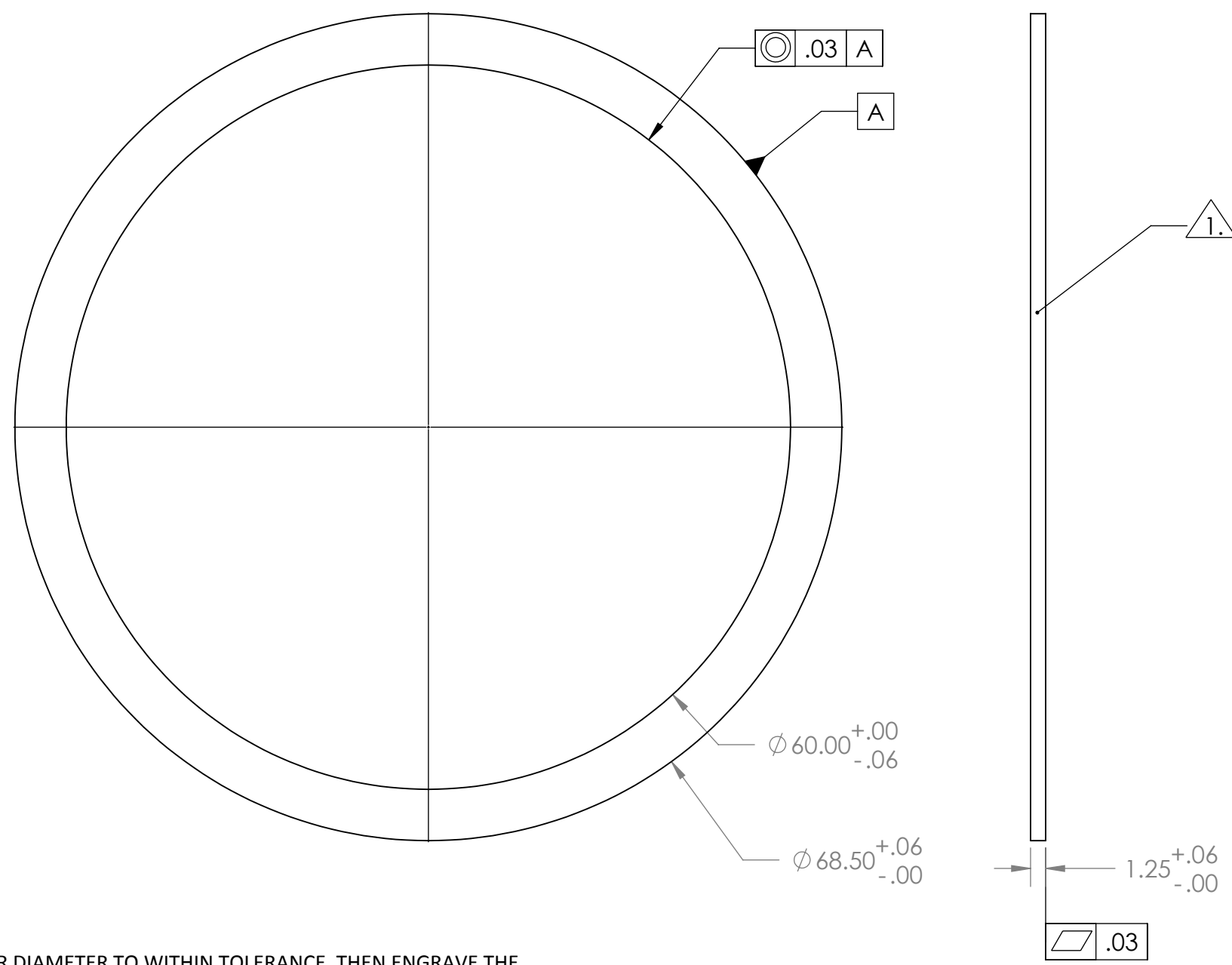

NOTES:

1. TURN OUTER DIAMETER TO WITHIN TOLERANCE, THEN ENGRAVE THE FOLLOWING USING A VIBRATORY TOOL WITH A TIP WITH A MINIMUM RADIUS OF .005":
 - a. HEAT NUMBER
 - b. LOT NUMBER
 - c. PART NUMBER
2. PROVIDE A COUPON, SIZED 2" X 2", FROM THE SAME HEAT NUMBER, LOT, AND THICKNESS OF THE MATERIAL.
3. NO WELD SPLICES OR REPAIR WELDING ALLOWED
4. MATERIAL IDENTIFICATION TO BE MAINTAINED AT ALL TIMES. IF IDENTIFICATION IS LOST, TESTING REQUIRED FOR THE MATERIAL MUST BE REPEATED.
5. NO GRINDING ALLOWED
6. FORGING MUST BE PROTECTED FROM CONTAMINATION FROM CARBON STEEL OR HYDROCARBONS. KEEP FORGINGS PROTECTED AT ALL TIMES.
7. PACKAGE FORGINGS PER ASTM A-700.

DESCRIPTION FORGING, 1.25 THK, 60.00 ID, 68.50 OD		WEIGHT: 309.92#		<p>GNB CORPORATION SCIENTIFIC AND INDUSTRIAL EQUIPMENT 3200 DWIGHT RD. SUITE 100 ELK GROVE, CA, 95758 916-395-3003 FAX: 916-395-3363 www.gnbvalves.com</p>
MATERIAL: AISI 304L PER ASME SPEC SA-182 GRADE F; MAX SULFUR CONTENT .006%		APPROVALS	DATE	
UNLESS OTHERWISE SPECIFIED: DIMENSIONS ARE IN INCHES TOLERANCES: ANGULAR: $\pm 1^{\circ}0'$.XX $\pm .06$.XXX $\pm .005$ UNSPECIFIED FILLETS: R.015 BREAK EDGES .010x45° REMOVE ALL BURRS		DRAFTER MKM2	6/14/10	
FINISH 250		CHECKER RW	6/14/10	TITLE: FORGING, FLANGE, 60 ID X 68.50 OD
//, /, ⊥ WITHIN .03		ENGINEER MKM2	6/14/10	
THIRD ANGLE PROJECTION		DO NOT SCALE DRAWING		DWG. NO. B 114324-00S SCALE: 1:12
		SHEET 1 OF 1		REV