

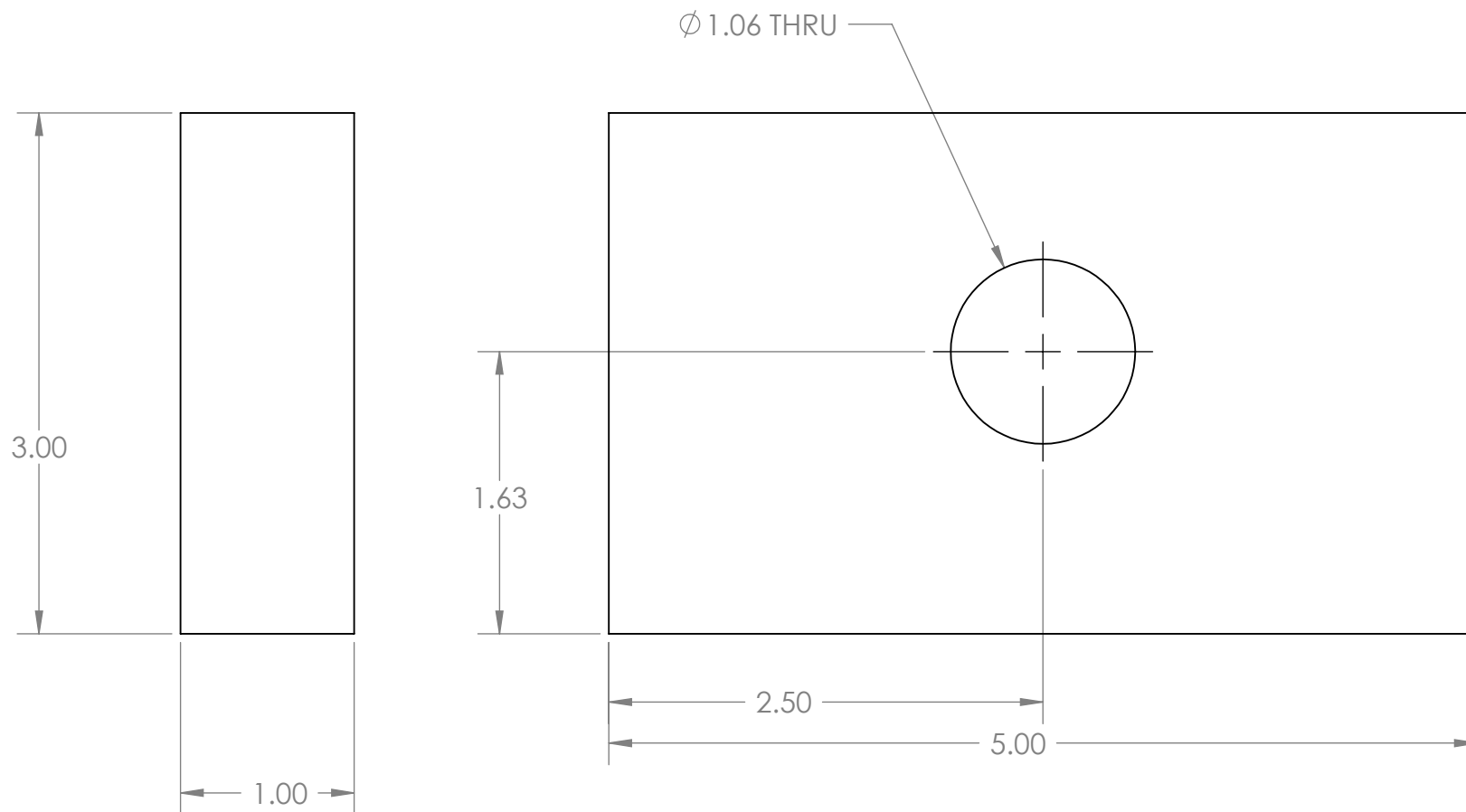

PROPRIETARY AND CONFIDENTIAL
 THE INFORMATION CONTAINED IN THIS
 DRAWING IS THE SOLE PROPERTY OF
 GNB CORPORATION. ANY
 REPRODUCTION IN PART OR AS A WHOLE
 WITHOUT THE WRITTEN PERMISSION OF
 GNB CORPORATION IS PROHIBITED.

ZONE		REV.	DESCRIPTION	REVISIONS	DATE	APPROVED
------	--	------	-------------	-----------	------	----------



DESCRIPTION: PLATE, 1.00 THK, 3.00 WD, 5.00 LG		 SCIENTIFIC AND INDUSTRIAL EQUIPMENT 3200 DWIGHT RD, SUITE 100 ELK GROVE, CA 95758 916-395-3003 FAX: 916-395-3363 WWW.GNBVALVES.COM															
MATERIAL: AISI 304/AISI 304L DUAL CERT PER SA240																	
UNLESS OTHERWISE SPECIFIED:	WEIGHT: 4.08 #	TITLE: PLATE, BACKING, NUT, TIE DOWN DWG. NO. A 114232-01S SCALE: 1:1 SHEET 1 OF 1															
DIMENSIONS ARE IN INCHES	<table border="1"> <thead> <tr> <th colspan="3">APPROVALS</th> </tr> <tr> <th></th> <th>NAME</th> <th>DATE</th> </tr> </thead> <tbody> <tr> <td>DRAFTER</td> <td>MKM2</td> <td>6/11/10</td> </tr> <tr> <td>CHECKER</td> <td>RW</td> <td>6/14/10</td> </tr> <tr> <td>ENGINEER</td> <td>MKM2</td> <td>6/11/10</td> </tr> </tbody> </table>		APPROVALS				NAME	DATE	DRAFTER	MKM2	6/11/10	CHECKER	RW	6/14/10	ENGINEER	MKM2	6/11/10
APPROVALS																	
			NAME	DATE													
DRAFTER		MKM2	6/11/10														
CHECKER	RW	6/14/10															
ENGINEER	MKM2	6/11/10															
TOLERANCES:																	
ANGULAR: ± 1°	FINISH 125																
.XX ± .01		THIRD ANGLE PROJECTION 															
.XXX ± .005																	
UNSPECIFIED FILLETS: R.015																	
BREAK EDGES .010 x 45°																	
REMOVE ALL BURRS																	
// □ ⊥ WITHIN .03																	
DO NOT SCALE DRAWING		REV -															

5

4

3

2

1