

PROPRIETARY AND CONFIDENTIAL
 THE INFORMATION CONTAINED IN THIS
 DRAWING IS THE SOLE PROPERTY OF
 GNB CORPORATION. ANY
 REPRODUCTION IN PART OR AS A WHOLE
 WITHOUT THE WRITTEN PERMISSION OF
 GNB CORPORATION IS PROHIBITED.

ZONE		REV.	DESCRIPTION	DATE	APPROVED
		A	RELEASED TO PRODUCTION	8/23/2010	MKM2

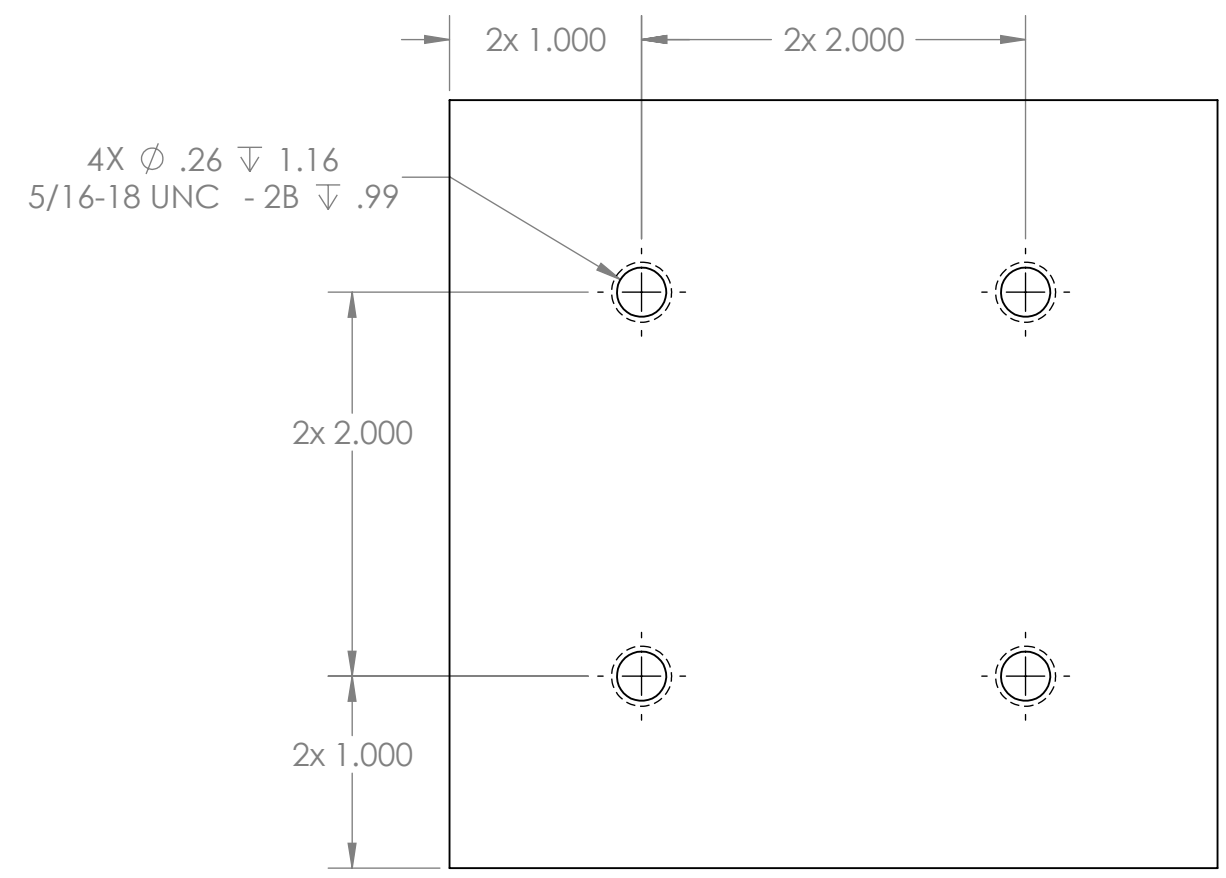
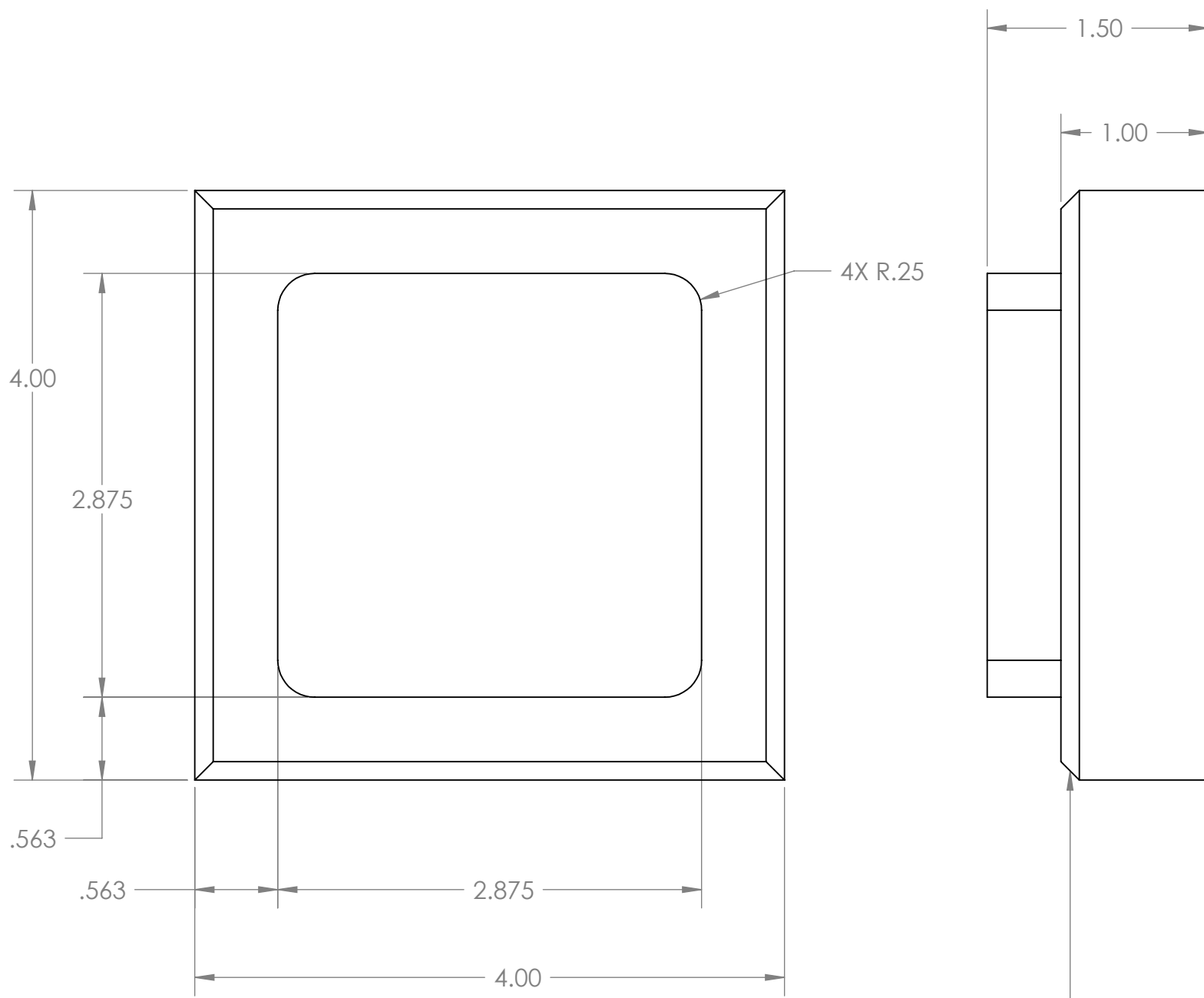

.13 X 45°
ALL AROUND

DESCRIPTION PLATE, 1.50 THK, 4.00 WD, 4.00 LG
 MATERIAL: ASTM A36 Steel
 WEIGHT: 5.60#

APPROVALS	DATE
DRAFTER MKM2	7/7/10
CHECKER ER	8/16/10
ENGINEER MKM2	7/7/10

GNB CORPORATION
 SCIENTIFIC AND INDUSTRIAL EQUIPMENT
 3200 DWIGHT RD. SUITE 100
 ELK GROVE, CA, 95758
 916-395-3003 FAX: 916-395-3363
 www.gnbvalves.com

TITLE: **PLATE, BOLT, STAND
 MIDSTATION SPOOL**

DO NOT SCALE DRAWING
 DWG. NO. **B** 114282-00M
 SCALE: 1:1 SHEET 1 OF 1
 REV **A**

UNLESS OTHERWISE SPECIFIED:
 DIMENSIONS ARE IN INCHES
 TOLERANCES:
 ANGULAR: \pm 0°30'
 .XX \pm .03
 .XXX \pm .005
 UNSPECIFIED FILLETS: R.015
 BREAK EDGES .010x45°
 REMOVE ALL BURRS
 //, \square , \perp WITHIN .03
 THIRD ANGLE PROJECTION