

PROPRIETARY AND CONFIDENTIAL  
 THE INFORMATION CONTAINED IN THIS  
 DRAWING IS THE SOLE PROPERTY OF  
 GNB CORPORATION. ANY  
 REPRODUCTION IN PART OR AS A WHOLE  
 WITHOUT THE WRITTEN PERMISSION OF  
 GNB CORPORATION IS PROHIBITED.

REVISIONS				
ZONE	REV.	DESCRIPTION	DATE	APPROVED
	A	ADDED PAINT SPECIFICATION	8/3/2010	MKM2
	B	REVISED WELD CALL-OUTS	8/11/2010	MKM2
	C	RELEASED TO PRODUCTION	8/25/2010	MKM2

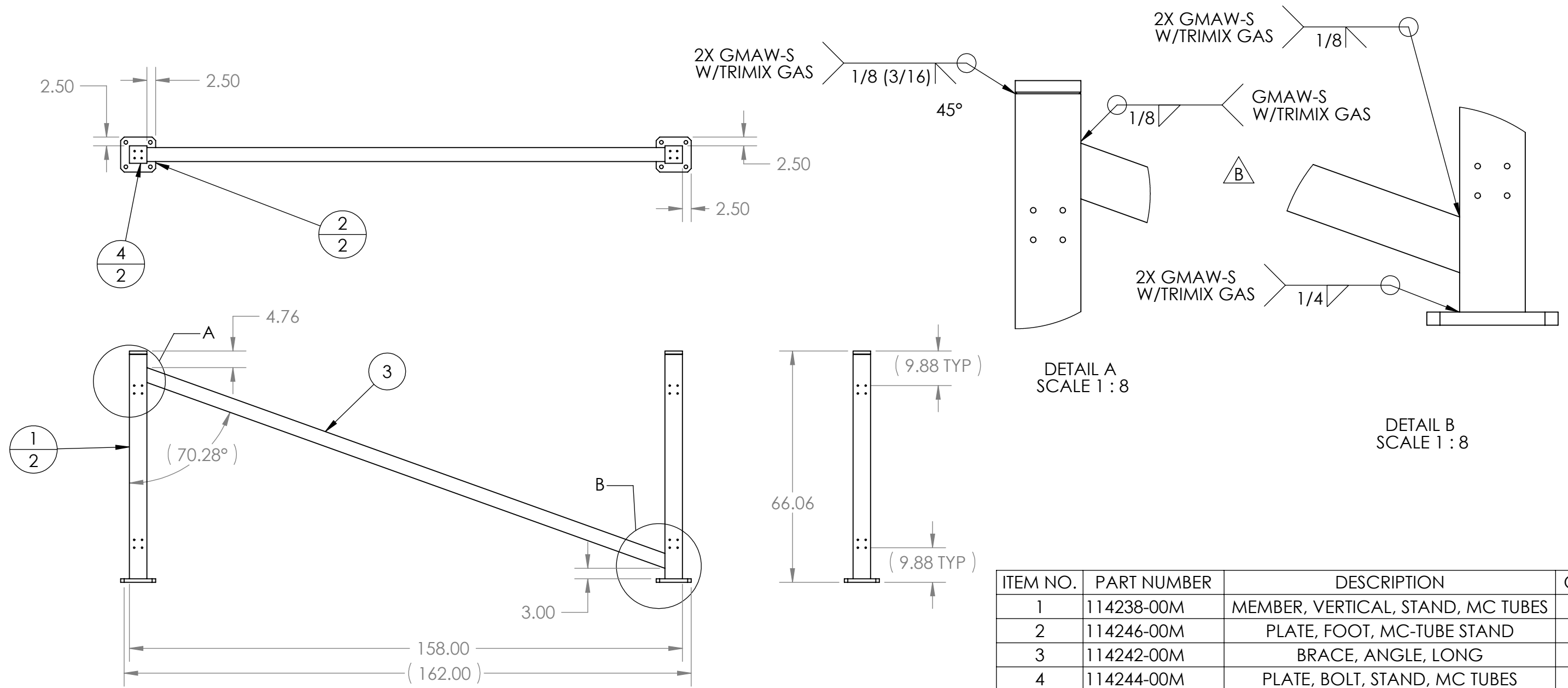

ITEM NO.	PART NUMBER	DESCRIPTION	QTY.
1	114238-00M	MEMBER, VERTICAL, STAND, MC TUBES	2
2	114246-00M	PLATE, FOOT, MC-TUBE STAND	2
3	114242-00M	BRACE, ANGLE, LONG	1
4	114244-00M	PLATE, BOLT, STAND, MC TUBES	2

- NOTES:
1. WELD PER QP1750-W2, LIGO WELDING AND REPAIR PROCEDURE, LATEST REVISION
  2. ALL WELDS TO BE GMAW-S, TRIMIX GAS
  3. NO POST WELD HEAT TREATMENT IS REQUIRED
  4. PLACE SCREWS IN THE TAPPED HOLES TO PREVENT PAINT FROM GETTING IN THE HOLES.
  5. PRIOR TO PAINTING, PREPARE SURFACE TO SSPC SP-10 (NEAR WHITE) BLAST CLEANING
  6. REFER TO QP112, SECTIONS 1.4, 1.5, AND 1.6
  7. PAINT WITH GRAY INORGANIC ZINC PAINT, LOW VOC. DFT SHOULD BE BETWEEN .004 AND .005"

MATERIAL: ASTM A36 STEEL

UNLESS OTHERWISE SPECIFIED:  
 DIMENSIONS ARE IN INCHES  
 TOLERANCES:  
 ANGULAR: ± 0°30'  
 .XX ± .03  
 .XXX ± .005  
 UNSPECIFIED FILLETS: R.015  
 BREAK EDGES .010x45°  
 REMOVE ALL BURRS

FINISH 125

APPROVALS

DRAFTER	MKM2	DATE	7/7/10
CHECKER	RW	DATE	7/22/10
ENGINEER	MKM2	DATE	7/7/10

WGT: 484.34#

GNB CORPORATION  
 SCIENTIFIC AND INDUSTRIAL EQUIPMENT  
 3200 DWIGHT RD. SUITE 100  
 ELK GROVE, CA, 95758  
 916-395-3003 FAX: 916-395-3363  
 www.gnbvalves.com

TITLE: WELDMENT, MCB TUBE STAND

DO NOT SCALE DRAWING

THIRD ANGLE PROJECTION

DWG. NO. 114237-00WM  
 SCALE: 1:30  
 SHEET 1 OF 1

REV C