

PROPRIETARY AND CONFIDENTIAL
 THE INFORMATION CONTAINED IN THIS
 DRAWING IS THE SOLE PROPERTY OF
 GNB CORPORATION. ANY
 REPRODUCTION IN PART OR AS A WHOLE
 WITHOUT THE WRITTEN PERMISSION OF
 GNB CORPORATION IS PROHIBITED.

REV. NO.		DESCRIPTION	DATE	APPROVED
A		REVISED WELD SIGNS	8/11/2010	MKM2
B		REVISED STIFFENER WELDMENT TO BUTT WELDING, RELEASED TO PRODUCTION	8/24/2010	MKM2
C		RETURNED STIFFENER WELDMENT TO V GROOVE	8/23/2010	MKM2

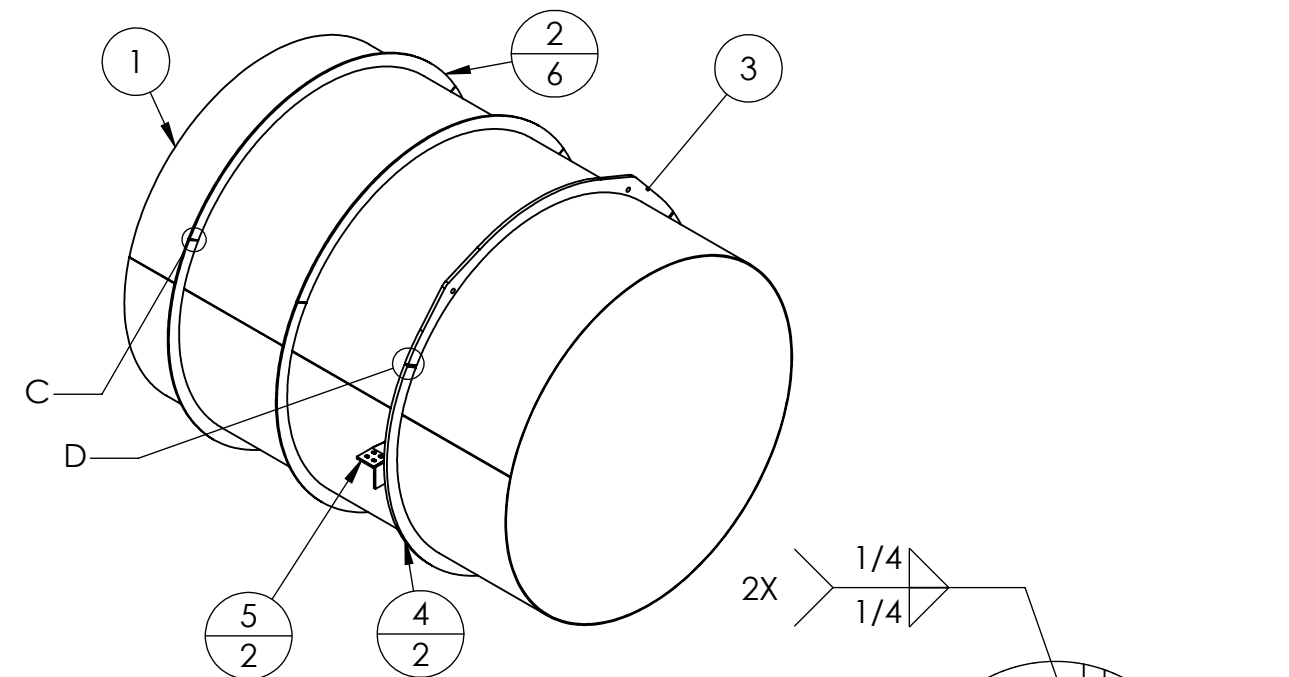

VAC TIGHT
 USE NO BACKING STRIPS
 FULL PENETRATION

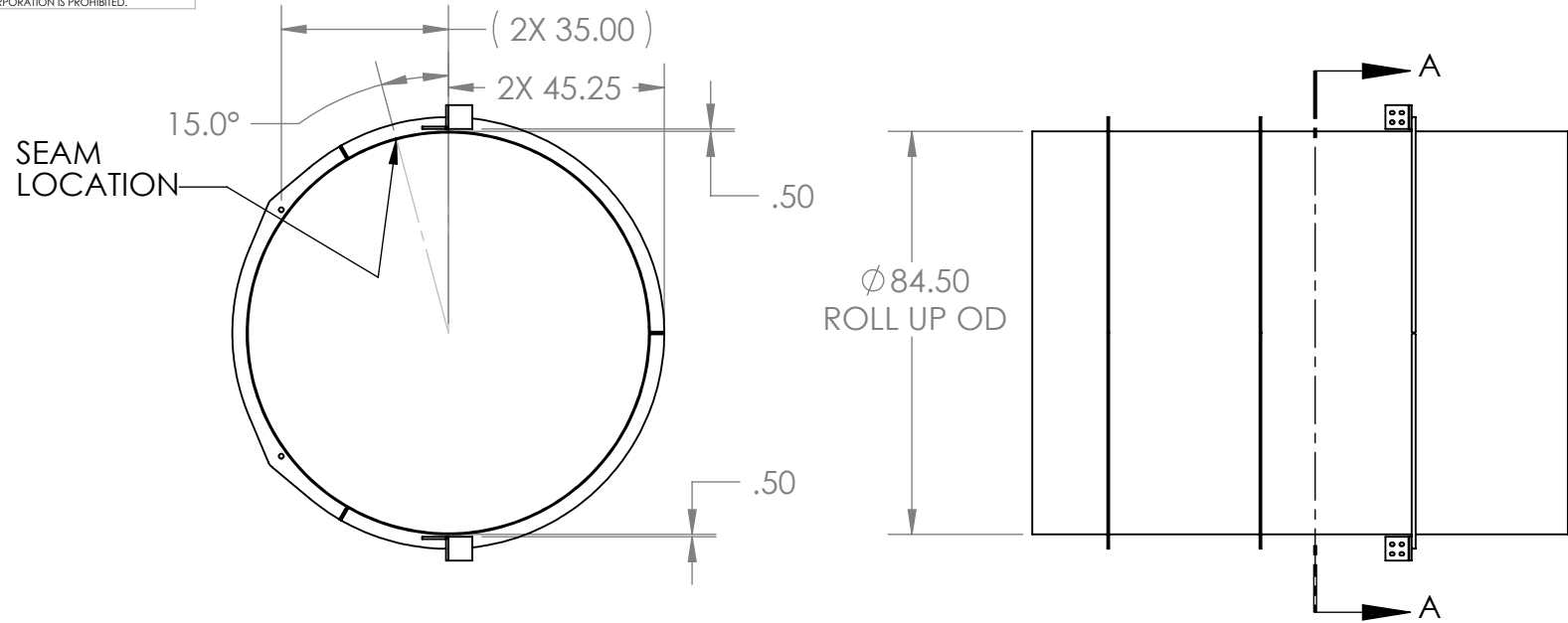
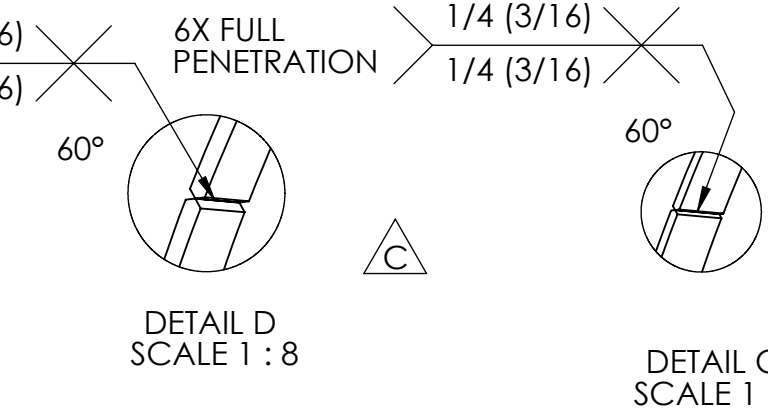
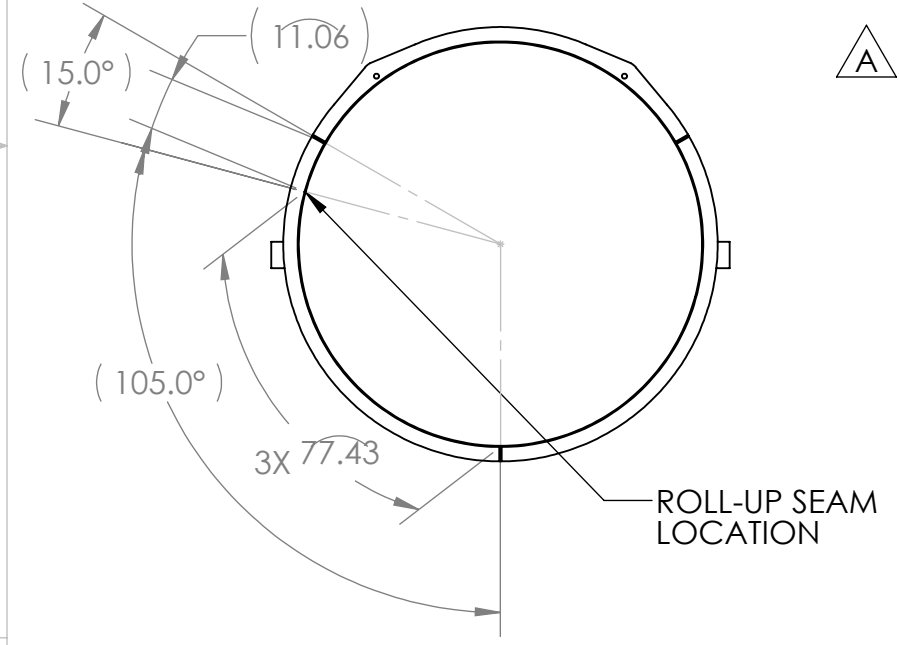
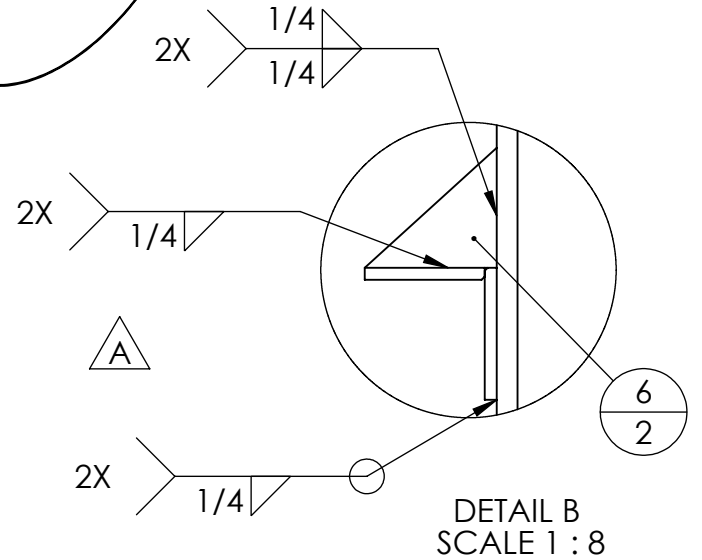
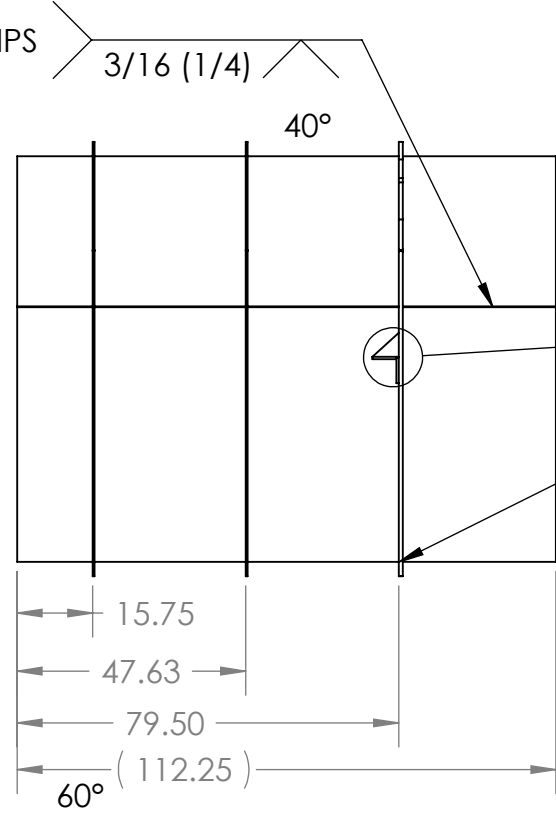

ITEM NO.	PART NUMBER	DESCRIPTION	QTY.
1	114203-01S	ROLL-UP, MC-A TUBES	1
2	114204-00S	STIFFENER, 1/3, PLAIN, MC TUBE	6
3	114205-00S	STIFFENER, LIFTING, MC TUBES	1
4	114206-00S	STIFFENER, THICK, MC TUBES	2
5	114207-00WS	WELDMENT, BRACKET, MC TUBE	2
6	114427-00S	PLATE, BRACKET, BRACE	2

- NOTES:
1. ALL WELD PREPS TO BE DONE BY TUNGSTEN CARBIDE CUTTING TOOLS ONLY
 2. WELD PER QP1750-W2, LIGO WELDING AND REPAIR PROCEDURE, LATEST REVISION
 3. CLEAN WELD WIRE AND SURFACES TO BE WELDED WITH CO2 SCRUBBING
 4. INTERNAL WELD SURFACE TO BE SMOOTH BUT NOT GROUND
 5. ALL WELDS TO BE GTAW UNLESS OTHERWISE NOTED
 6. ALL INTERNAL WELDS TO BE CONTINUOUS AND VACUUM TIGHT
 7. NO POST WELD HEAT TREATMENT IS REQUIRED

MATERIAL: AISI 304/AISI 304L DUAL CERT PER SA240

UNLESS OTHERWISE SPECIFIED: DIMENSIONS ARE IN INCHES
 TOLERANCES: ANGULAR: ± 0°30'
 .XX ± .03
 .XXX ± .005
 UNSPECIFIED FILLETS: R.015
 BREAK EDGES .010x45°
 REMOVE ALL BURRS

FINISH 125

WEIGHT: 2555.62#

APPROVALS: DRAFTER MKM2, CHECKER RW, ENGINEER MKM2, DATE 7/13/10, 7/22/10, 7/13/10

GNB CORPORATION
 SCIENTIFIC AND INDUSTRIAL EQUIPMENT
 3200 DWIGHT RD. SUITE 100
 ELK GROVE, CA, 95758
 916-395-3003 FAX: 916-395-3363
 www.gnbvalves.com

TITLE: WELDMENT, TUBE, LEFT, MC TUBE

DO NOT SCALE DRAWING

DWG. NO. 114250-00WS
 SCALE: 1:40
 SHEET 1 OF 1

REV C