

PROPRIETARY AND CONFIDENTIAL  
 THE INFORMATION CONTAINED IN THIS  
 DRAWING IS THE SOLE PROPERTY OF  
 GNB CORPORATION. ANY  
 REPRODUCTION IN PART OR AS A WHOLE  
 WITHOUT THE WRITTEN PERMISSION OF  
 GNB CORPORATION IS PROHIBITED.

REVISIONS				
ZONE	REV.	DESCRIPTION	DATE	APPROVED
	A	REMOVED CHAMFERS; RELEASED TO PRODUCTION	8/24/2010	MKM2
	B	ADDED WELD PREP	8/25/2010	MKM2

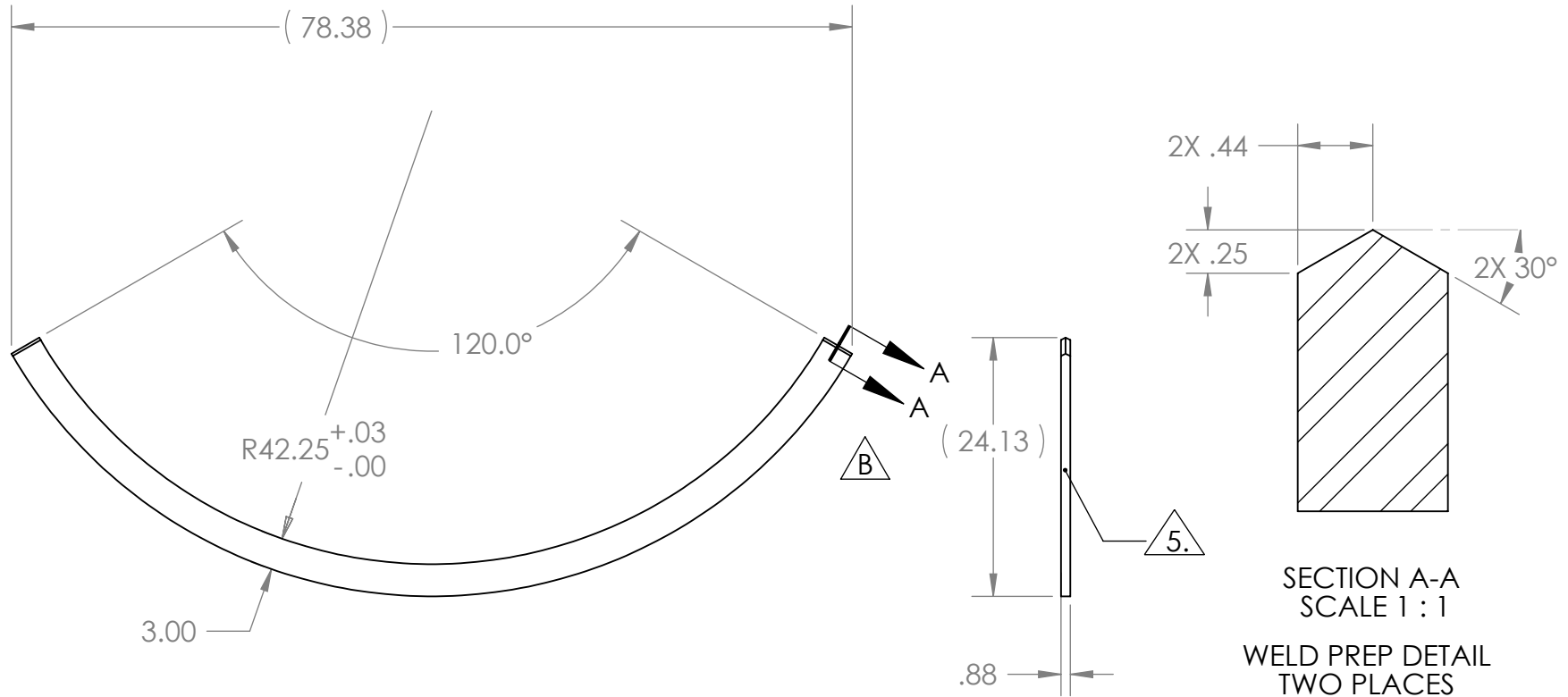

SECTION A-A  
 SCALE 1 : 1  
 WELD PREP DETAIL  
 TWO PLACES

NOTES:

- THE FOLLOWING ARE NOT ALLOWED: GRINDING, HONING, LAPPING, POLISHING, BUFFING, SANDING, BLASTING.
- NO HYDROCARBONS ALLOWED IN THE COOLANT. COOLANT LIMITS AS FOLLOWS
  - WATER LEACHABLE CHLORIDES: 100PPM
  - TOTAL HALOGENS (INCLUDING CHLORIDES): 1000PPM
  - TOTAL SULFER: 1000PPM
- DO NOT ALLOW PART TO BE CONTAMINATED BY CARBON STEEL OR IRON CONTACT.
- MACHINING TO BE IN LINE WITH LIGO SPECIFICATION E0900406, LATEST REVISION.

5. USING A VIBRATORY TOOL WITH A TIP WITH A MINIMUM RADIUS OF .005", ENGRAVE THE FOLLOWING ON THE INDICATED SURFACE:
- HEAT NUMBER
  - LOT NUMBER
  - PART NUMBER

DESCRIPTION: PLT, .88 THK, 24.13 WD, 78.38 LG		<p>SCIENTIFIC AND INDUSTRIAL EQUIPMENT</p> <p>3200 DWIGHT RD, SUITE 100        ELK GROVE, CA 95758        916-395-3003 FAX: 916-395-3363        WWW.GNBVALVES.COM</p>															
MATERIAL: AISI 304/AISI 304L DUAL CERT PER SA240																	
UNLESS OTHERWISE SPECIFIED:	WEIGHT: 69.33 #	<table border="1"> <thead> <tr> <th colspan="3">APPROVALS</th> </tr> <tr> <th></th> <th>NAME</th> <th>DATE</th> </tr> </thead> <tbody> <tr> <td>DRAFTER</td> <td>MKM2</td> <td>6/14/10</td> </tr> <tr> <td>CHECKER</td> <td>RW</td> <td>6/14/10</td> </tr> <tr> <td>ENGINEER</td> <td>MKM2</td> <td>6/14/10</td> </tr> </tbody> </table>	APPROVALS				NAME	DATE	DRAFTER	MKM2	6/14/10	CHECKER	RW	6/14/10	ENGINEER	MKM2	6/14/10
APPROVALS																	
	NAME		DATE														
DRAFTER	MKM2		6/14/10														
CHECKER	RW	6/14/10															
ENGINEER	MKM2	6/14/10															
DIMENSIONS ARE IN INCHES																	
TOLERANCES: FINISH																	
ANGULAR: ± 0°30'	125																
.XX ± .03																	
.XXX ± .005																	
UNSPECIFIED FILLETS: R.015																	
BREAK EDGES .010 x 45°																	
REMOVE ALL BURRS																	
// ◻ ⊥ WITHIN .03																	
THIRD ANGLE PROJECTION																	
DO NOT SCALE DRAWING		DWG. NO. <b>A</b> 114206-00S SCALE: 1:16															
		SHEET 1 OF 1 REV B															