

D1001970_d1lIGO_AOS_Manifold Cryo Baffle_Suspension Rod, PART PDM REV: X-020, DRAWING PDM REV: X-017

NOTES CONTINUED:
 5. SCRIBE, ENGRAVE (A VIBRATORY TOOL MAY BE USED), LASER MARK OR MECHANICALLY STAMP (NO INKS OR DYES) DRAWING PART NUMBER, REVISION (AND VARIANT OR "TYPE" IF APPLICABLE) ON NOTED SURFACE OF PART FOLLOWED ON THE NEXT LINE WITH A THREE DIGIT SERIAL NUMBER. SERIAL NUMBERS START AT 001 FOR THE FIRST ARTICLE AND PROCEED CONSECUTIVELY. USE MINIMUM 0.12" HIGH CHARACTERS, UNLESS THE SIZE OF THE PART DICTATES SMALLER CHARACTERS. EXAMPLE: DXXXXXX-VY, TYPE-XX, S/N XXX

- 6. APPROXIMATE WEIGHT = 0.184 LB.
- 7. MACHINE ALL SURFACES TO REMOVE OXIDES AND MILL FINISH. USE OF ABRASIVE REMOVAL TECHNIQUES IS NOT ALLOWED.
- 8. ALL PARTS SHALL BE MANUFACTURED IN ACCORDANCE WITH LIGO SPECIFICATION E0900364.

REV.	DATE	DCN #	DRAWING TREE #
v1	5 OCT 2010	E1000185	E1000358
v2	12 MAY 2011	E1000360-v2	-
-	-	-	-

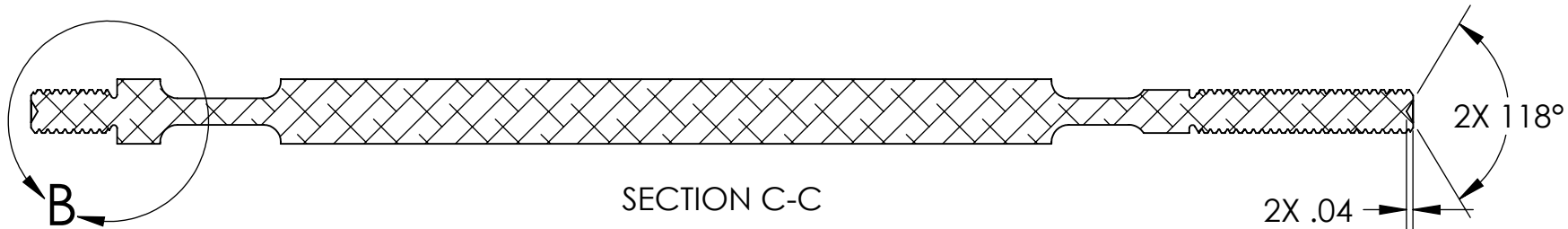
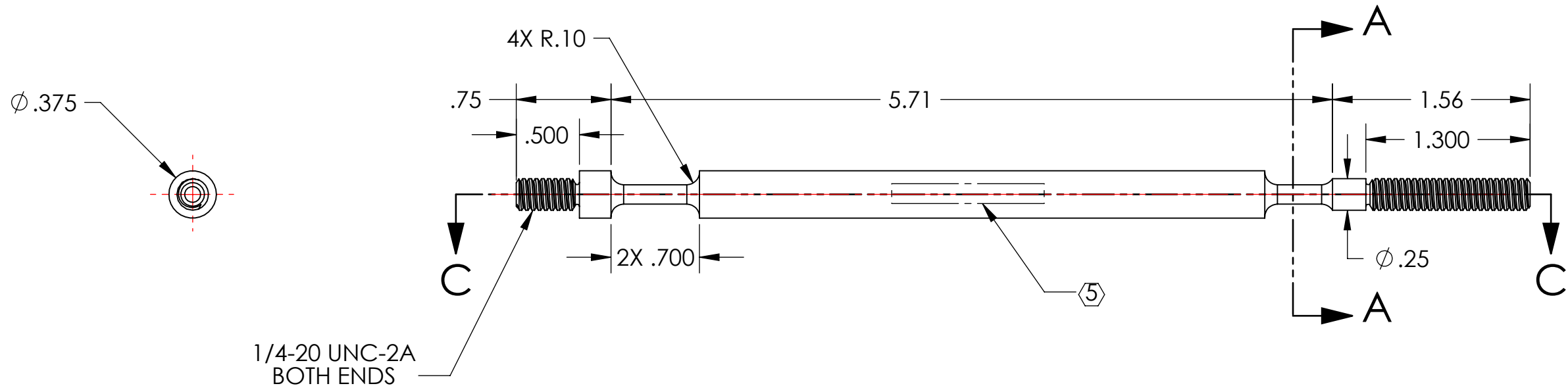
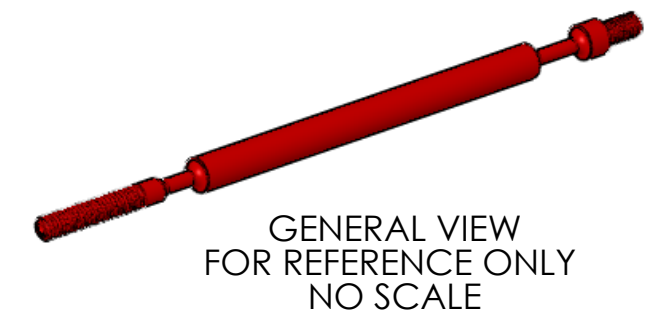
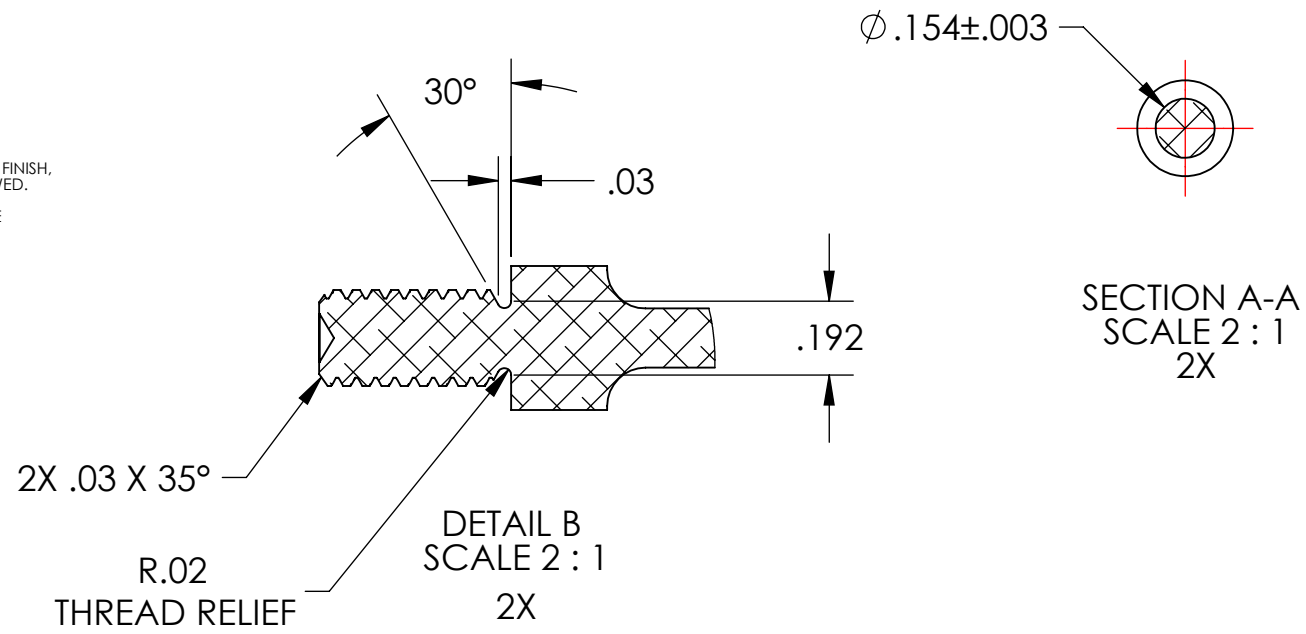

NOTES AND TOLERANCES: (UNLESS OTHERWISE SPECIFIED)				LIGO CALIFORNIA INSTITUTE OF TECHNOLOGY MASSACHUSETTS INSTITUTE OF TECHNOLOGY		PART NAME	
DIMENSIONS ARE IN INCHES TOLERANCES: .XX ± .01 .XXX ± .005 ANGULAR ± 0.5°				1. INTERPRET DRAWING PER ASME Y14.5-1994. 2. REMOVE ALL SHARP EDGES, R.02 MIN. 3. DO NOT SCALE FROM DRAWING. 4. ALL MACHINING FLUIDS MUST BE FULLY SYNTHETIC, FULLY WATER SOLUBLE AND FREE OF SULFUR, SILICONE, AND CHLORINE.		SUSPENSION ROD	
						SYSTEM: ADVANCED LIGO SUB-SYSTEM: AOS	
MATERIAL: 304, 316 OR 302 SSSL FINISH: 63 μinch				NEXT ASSY: D0902617		DESIGNER: TQ. NGUYEN 02 AUG 2010	SIZE DWG. NO. B
						DRAFTER: TQ. NGUYEN 06 AUG 2010	D1001970
						CHECKER: M. SMITH	REV. v2
						APPROVAL: D. COYNE	SCALE: 1:1 PROJECTION: SHEET 1 OF 1