

NOTES CONTINUED:
 5. SCRIBE, ENGRAVE, OR MECHANICALLY STAMP (NO INKS OR DYES) DRAWING PART NUMBER, REVISION (AND VARIANT OR "TYPE" IF APPLICABLE) ON NOTED SURFACE OF PART FOLLOWED ON THE NEXT LINE WITH A THREE DIGIT SERIAL NUMBER. SERIAL NUMBERS START AT 001 FOR THE FIRST ARTICLE AND PROCEED CONSECUTIVELY. USE MINIMUM 0.12" HIGH CHARACTERS, UNLESS THE SIZE OF THE PART DICTATES SMALLER CHARACTERS. A VIBRATORY TOOL MAY BE USED.
 EXAMPLE: DXXXXXX-VY, TYPE-XX, S/N XXX

6. MACHINE ALL SURFACES TO REMOVE OXIDES AND MILL FINISH. USE OF ABRASIVE REMOVAL TECHNIQUES IS NOT ALLOWED.
 7. ALL PARTS SHALL BE MANUFACTURED IN ACCORDANCE WITH LIGO SPECIFICATION E0900364.

REV.	DATE	DCN #	DRAWING TREE #
v1	7 OCT 2010	E1000563	-
-	-	-	-
-	-	-	-

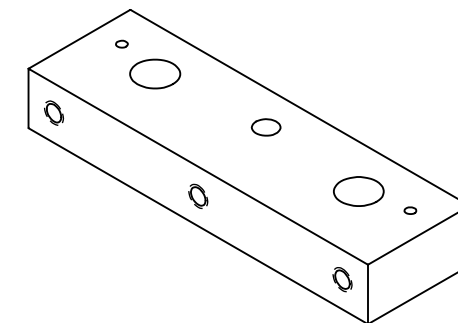
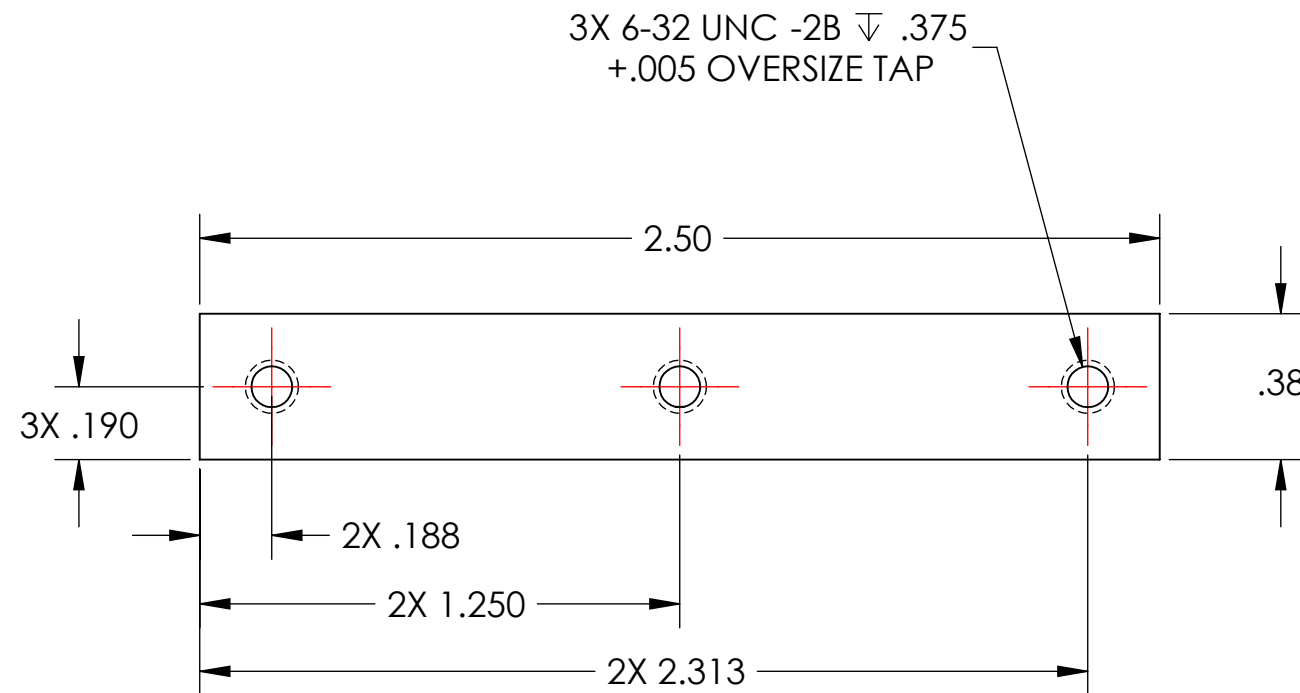

GENERAL VIEW
 FOR REFERENCE ONLY
 NO SCALE

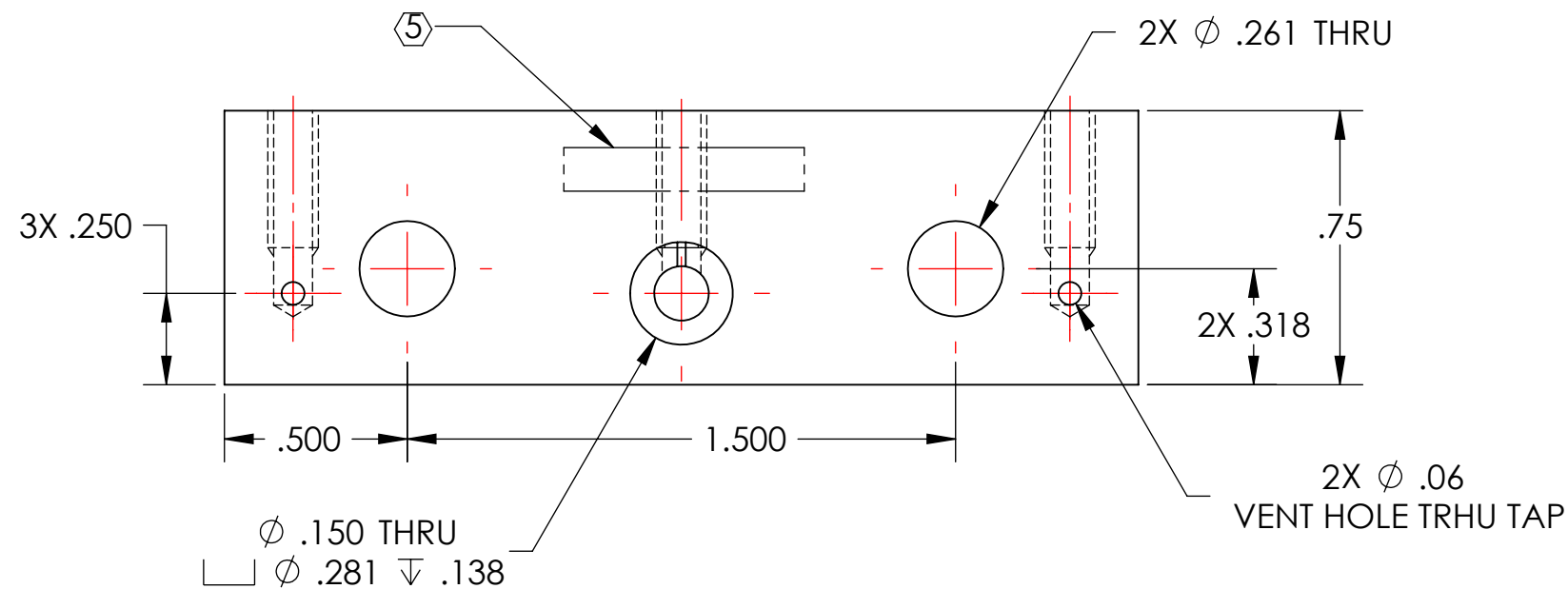

NOTES AND TOLERANCES: (UNLESS OTHERWISE SPECIFIED)

DIMENSIONS ARE IN INCHES

TOLERANCES:
 .XX \pm .01
 .XXX \pm .005

ANGULAR \pm 0.5°

1. INTERPRET DRAWING PER ASME Y14.5-1994.
 2. REMOVE ALL SHARP EDGES, R.02 MIN.
 3. DO NOT SCALE FROM DRAWING.
 4. ALL MACHINING FLUIDS MUST BE FULLY SYNTHETIC, FULLY WATER SOLUBLE AND FREE OF SULFUR, SILICONE, AND CHLORINE.

MATERIAL 6061-T6 Al

FINISH 63 μ inch

LIGO CALIFORNIA INSTITUTE OF TECHNOLOGY
 MASSACHUSETTS INSTITUTE OF TECHNOLOGY

SYSTEM ADVANCED LIGO

SUB-SYSTEM AOS

NEXT ASSY D1001963

PART NAME OUTPUT ALIGNMENT FIXTURE BASE

DESIGNER	TQ. NGUYEN	27 JUL 2010	SIZE	DWG. NO.	REV.
DRAFTER	TQ. NGUYEN	25 AUG 2010	B	D1001961	v1
CHECKER	M. SMITH		SCALE:	2:1	PROJECTION:
APPROVAL	D. COYNE				SHEET 1 OF 1