

Part "cover-2" (assembly item #9) is not to be included so that outgassing from the assembly does not deposit on the windows and cause a degradation in throughput over time (B. Willke, 10 June 2013, see E1300284-v1)

aLIGO PSL PMC D1001955-v1 assembly drawings

Patrick Kwee (patrick.kwee@aei.mpg.de), Jan Pöld (jan.poeld@aei.mpg.de)

PARTS LIST					
ITEM	QTY	CATEGORY	PART NUMBER	DESCRIPTION	FILE NAME
1	1		fank_bigring-2		fank_bigring-2.ipt
2	2		vitonpad2	Viton pad, 1mm thick	vitonpad2.ipt
3	1		vitonpad1	Viton pad, 1mm thick	vitonpad1.ipt
4	2		fankmount		fankmount.ipt
5	4		ring		ring.ipt
6	1		pmc_001		pmc_001.ipt
7	2		pmcmount_2		pmcmount_2.ipt
8	16		distance		distance.ipt
9	1		cover-2		cover-2.ipt
10	2		fakelemo		fakelemo.ipt
11	4	ASM	window-glue-adaptor		window-glue-adaptor.ipt
12	2	ASM	transadaptop		transadaptop.ipt
13	4	ASM	transadapbot		transadapbot.ipt
14	4	ASM	rod		rod.ipt
15	12	ASM	adap-rod		adap-rod.ipt
16	1	ASM	adap2		adap2.ipt
17	1	ASM	adap3		adap3.ipt
18	1	ASM	pztglue2		pztglue2.ipt
19	1	ASM	pztglue1		pztglue1.ipt

parts marked with 'asm' are used only for assembling

PURCHASE PARTS LIST				
ITEM	QTY	CATEGORY	PART NUMBER	DESCRIPTION
20	4		ANSI B18.3.1M - M6x1 x 100	Forged Socket Head Cap Screw - Metric
21	8		DIN 555-5 - M4	Hex Nut
22	1		ISO 4762 - M3 x 10	Hexagon Socket Head Cap Screw
23	16		ISO 4762 - M4 x 12	Hexagon Socket Head Cap Screw
24	12		ISO 4762 - M4 x 20	Hexagon Socket Head Cap Screw
25	2		ISO 4762 - M6 x 12	Hexagon Socket Head Cap Screw
26	8		ISO 4762 - M6 x 16	Hexagon Socket Head Cap Screw
27	4		ISO 4762 - M6 x 25	Hexagon Socket Head Cap Screw
28	1		ad590	AD590JF (2-Lead FLATPACK)
29	1		adhesive	MINCO #10PSA (3M)
30	8		glue	TRA-BOND 2101
31	1		glue2	Arctic Silver
32	2		heater	MINCO HK5165R52.3L12B
33	1		lemo0b2	Lemo HGG.0B.302.CLLSV
34	1		lemo0b4	Lemo HGG.0B.304.CLLSV
35	2		mirror-curved	Curved mirror T=68ppm, R=3m, ATF Coating Run V3-1210
36	2		mirror-flat	Flat mirror T=2.5%, ATF Coating Run V1-1732
37	1		pzt	PI PAHH-0013
38	4		vitonring	Viton o-ring, 4mm diameter, xx length
39	1		vitonring2	Viton o-ring, 6mm diameter, 480mm length
40	4		window	5deg wedged window, ATF Coating Run V2-1468-1
41	3		thorlabs-bbh1	Thorlabs BBH1/M (two handles per package)
42	4		bg39	Schott BG39 filter
43	2		DIN 555-5 - M8	Hex Nut
44	2		flatseal	1mm Viton flat sealing

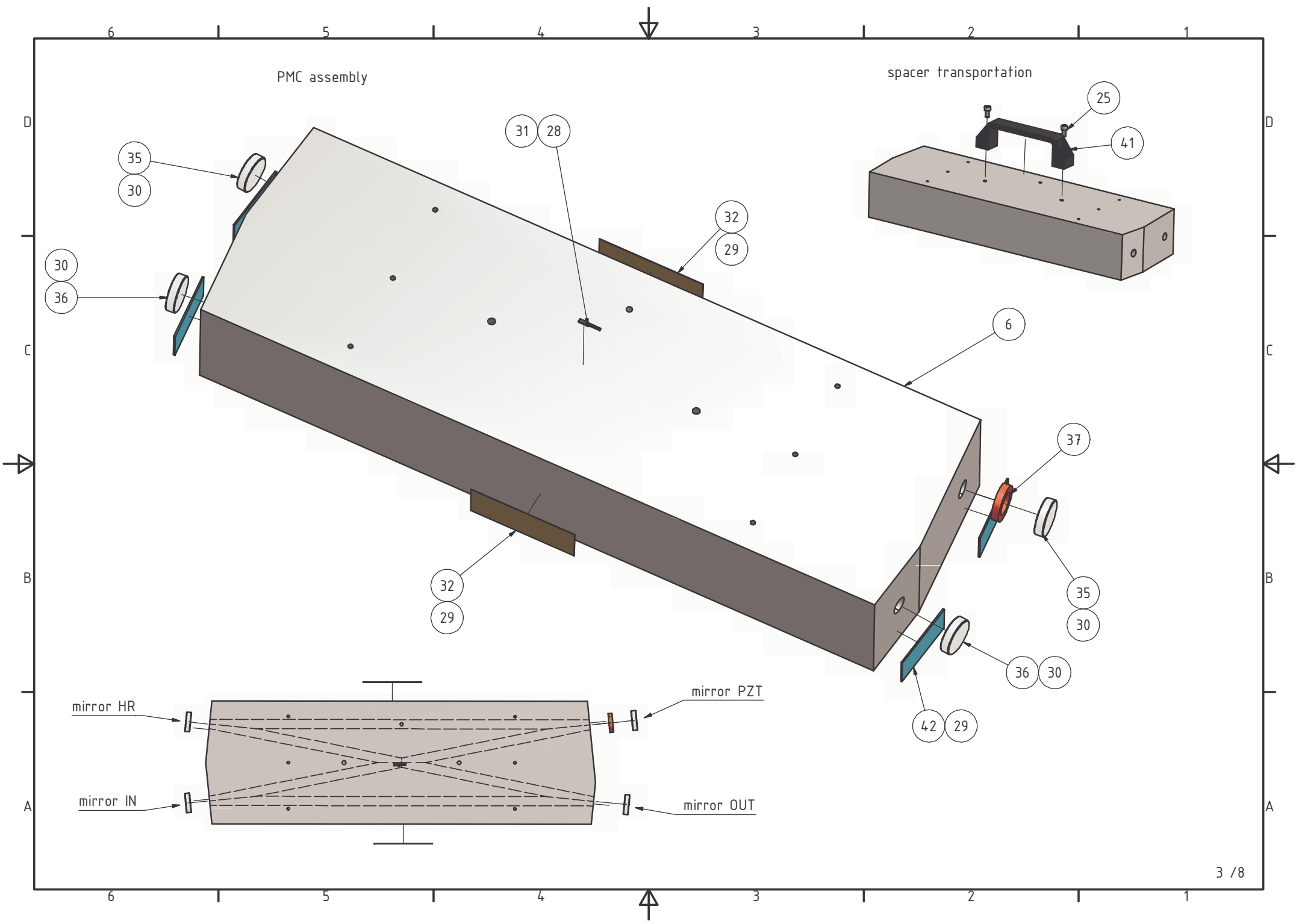

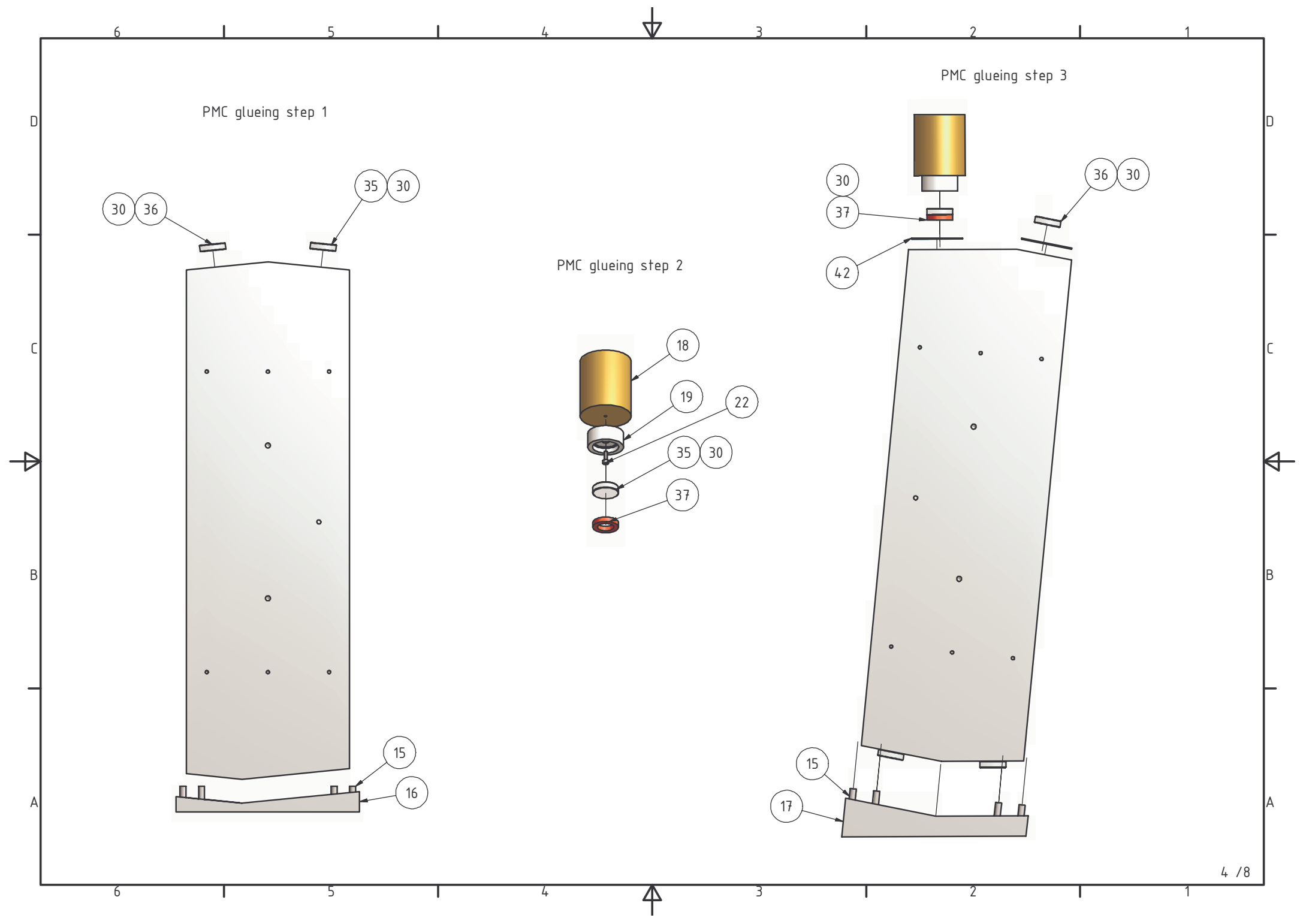

4x

window glue procedure

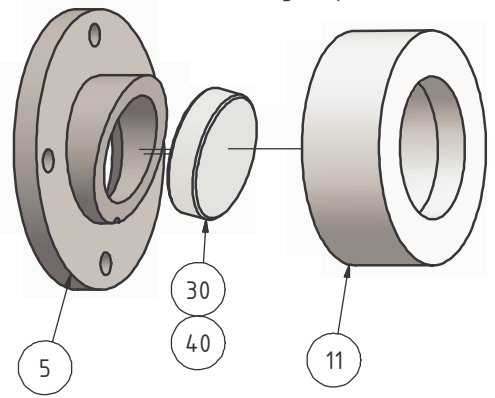

window assemble procedure

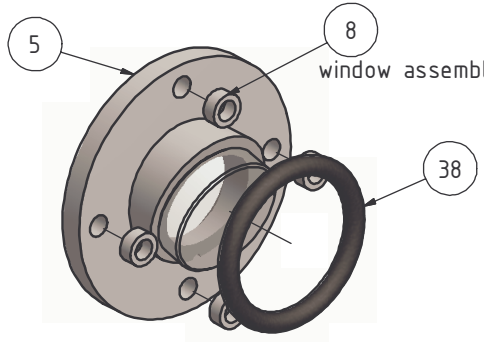

tank assemble procedure

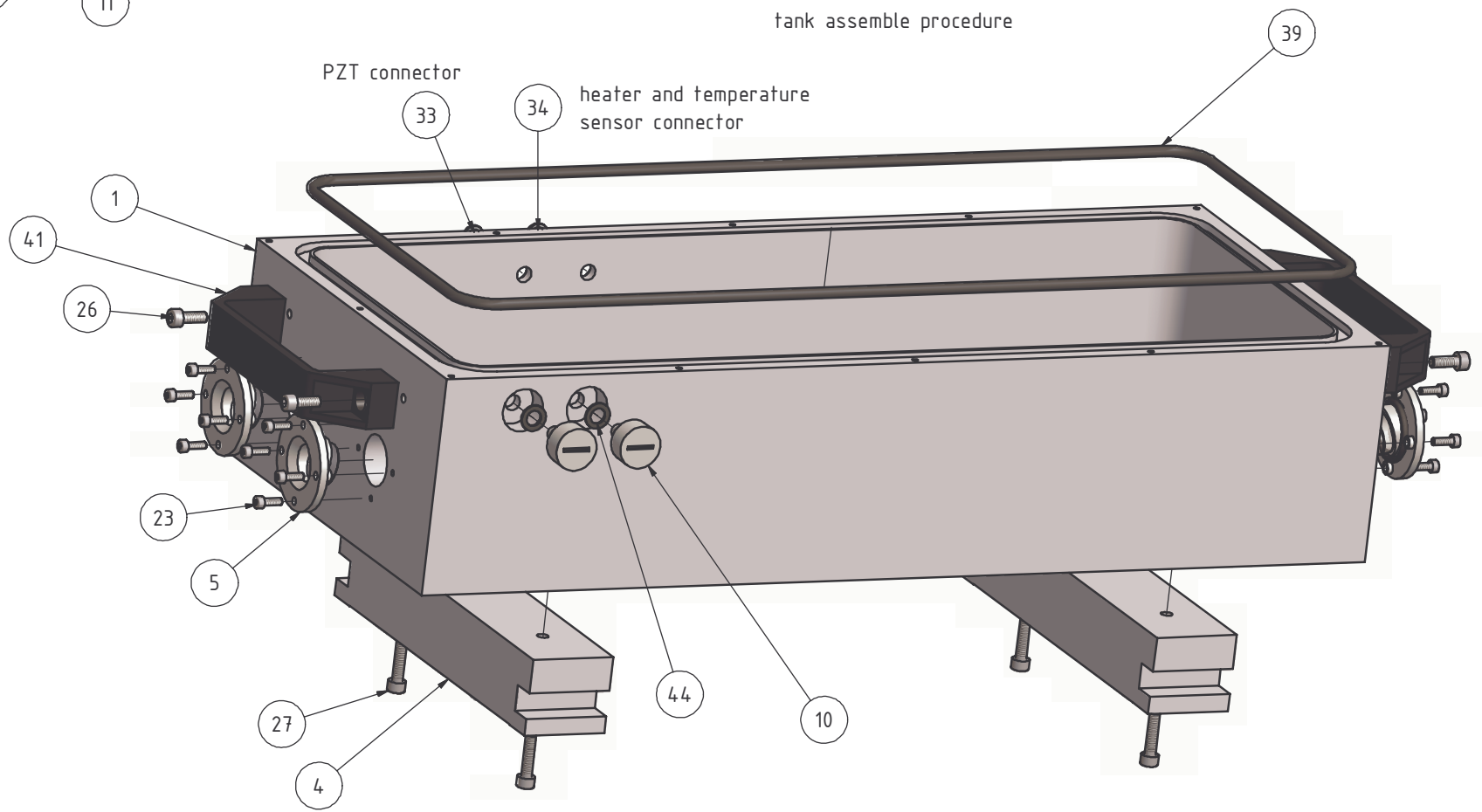

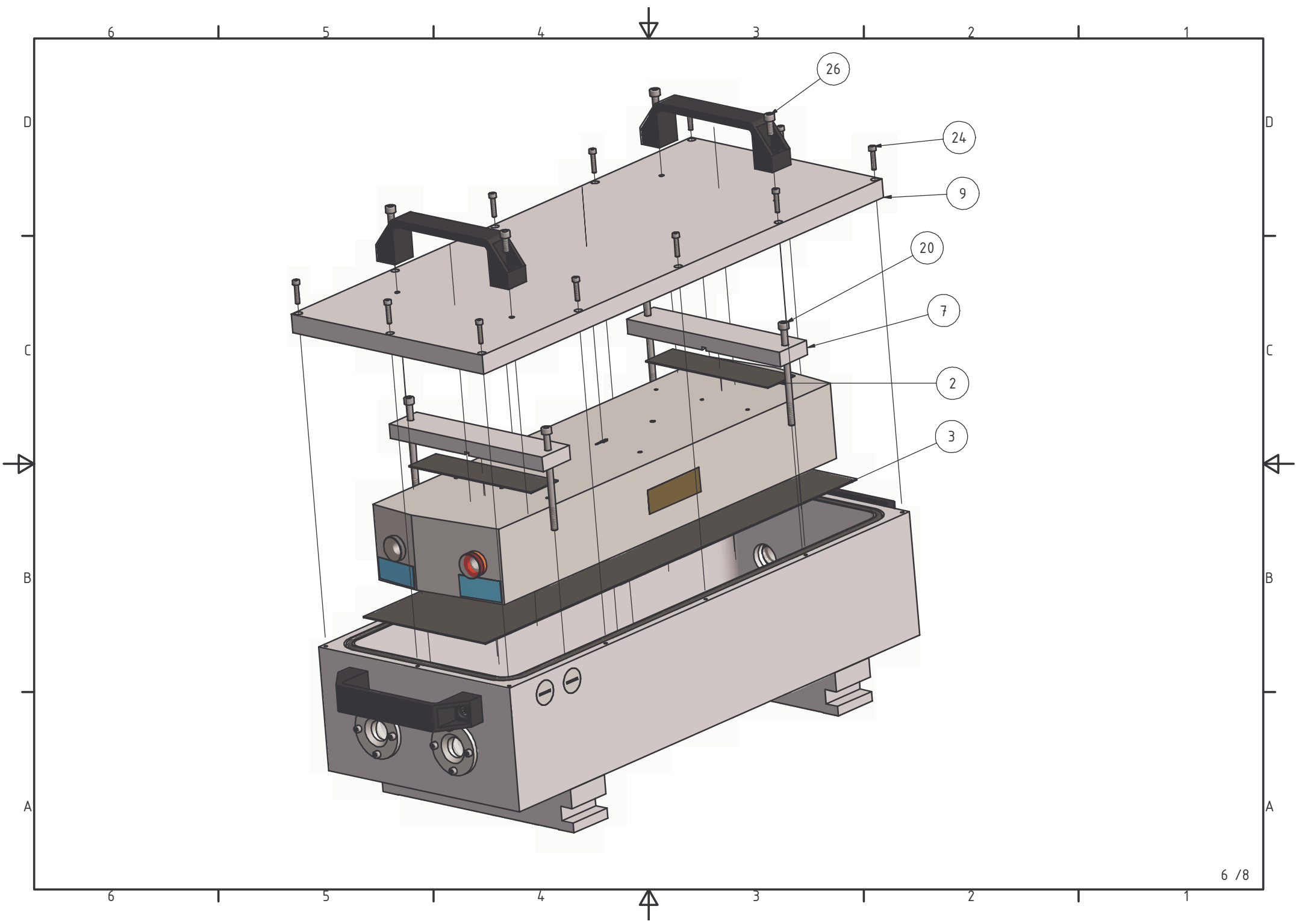

PMC in-tank positioning

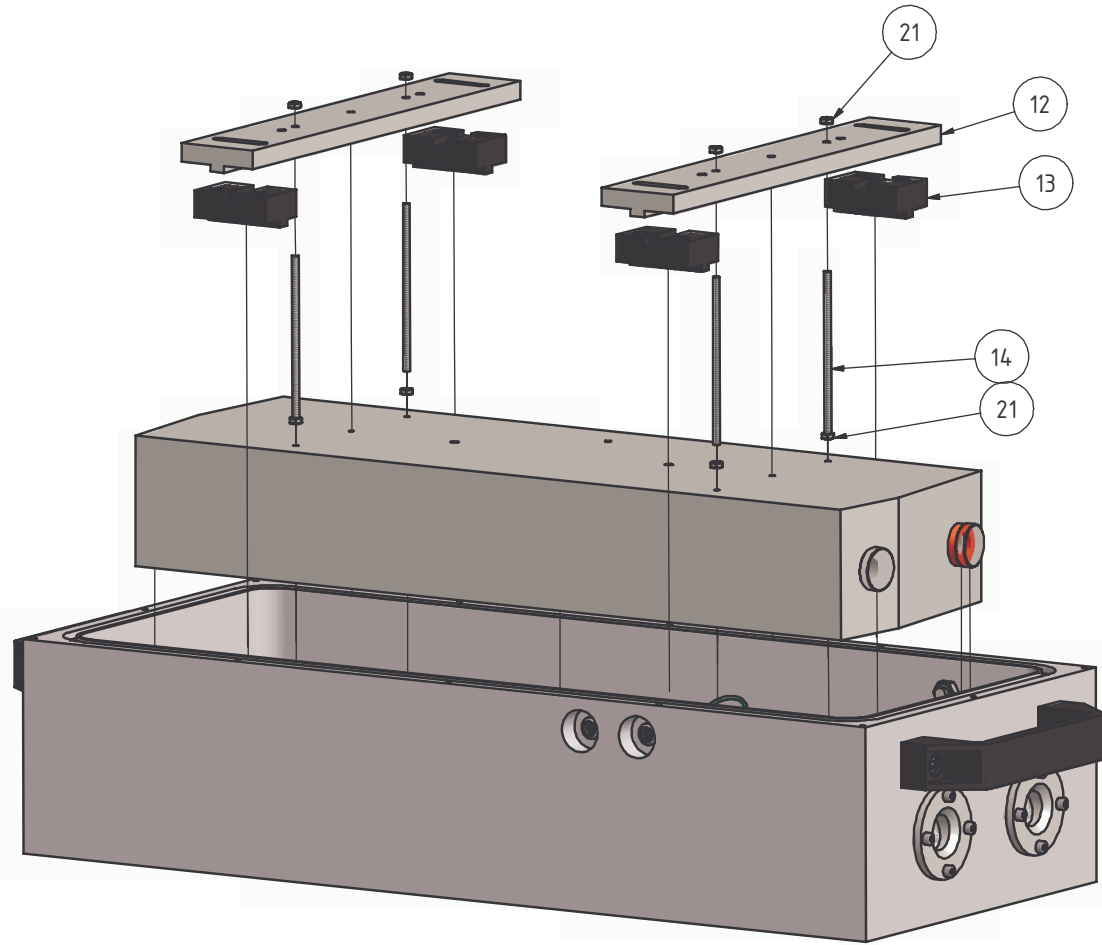

cabling and soldering

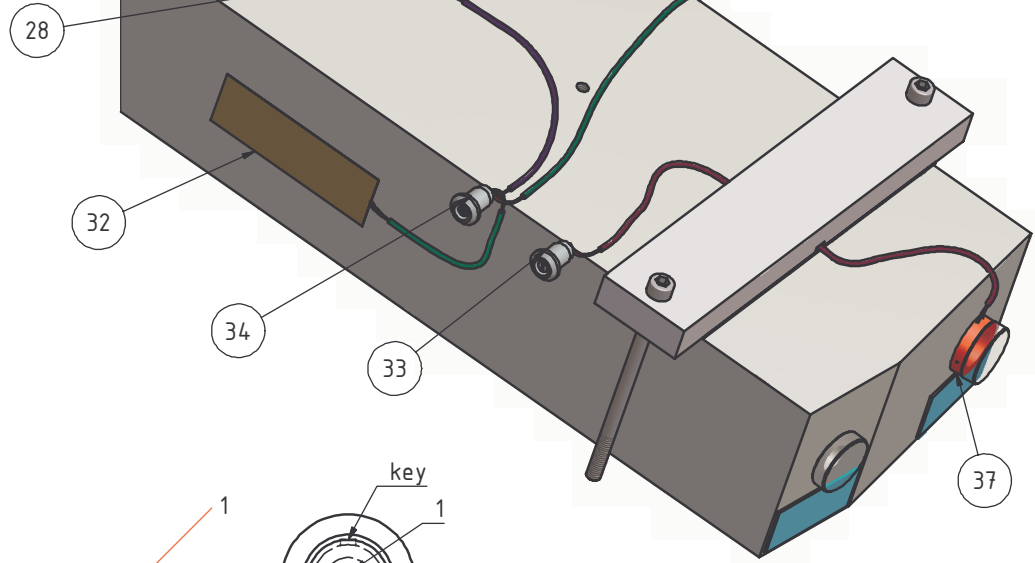

red wire
black wire

