

D1001892 aLIGO TMS Del-Tron-RS1-1-HORIZ. SLIDE ASSY., PART PDM REV: X-026, DRAWING PDM REV: X-009

REV.	DATE	DCN #	DRAWING TREE #
v1	10/12/2010	E1000318	-
v2	12 NOV 2010	E1000689	-
-	-	-	-

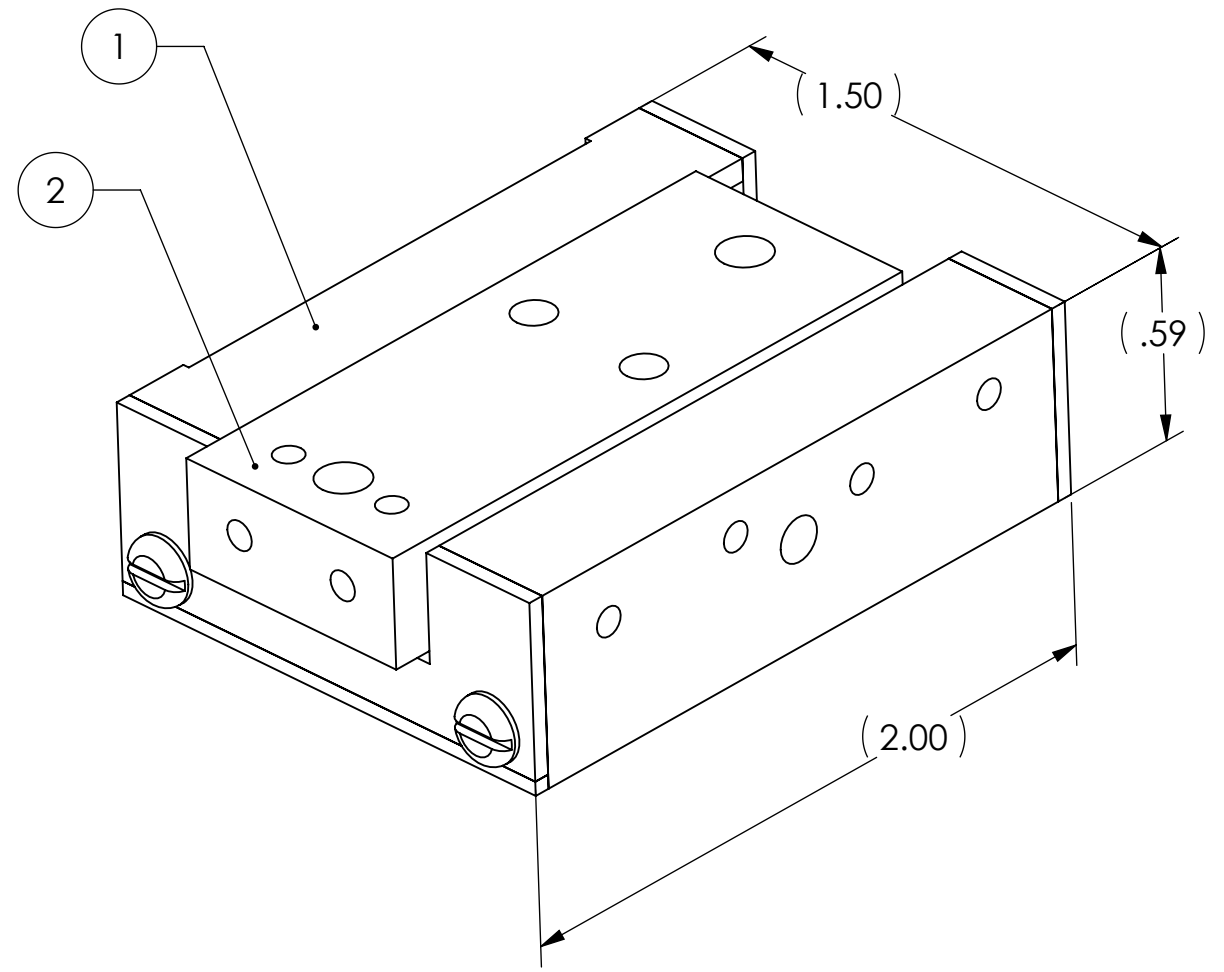
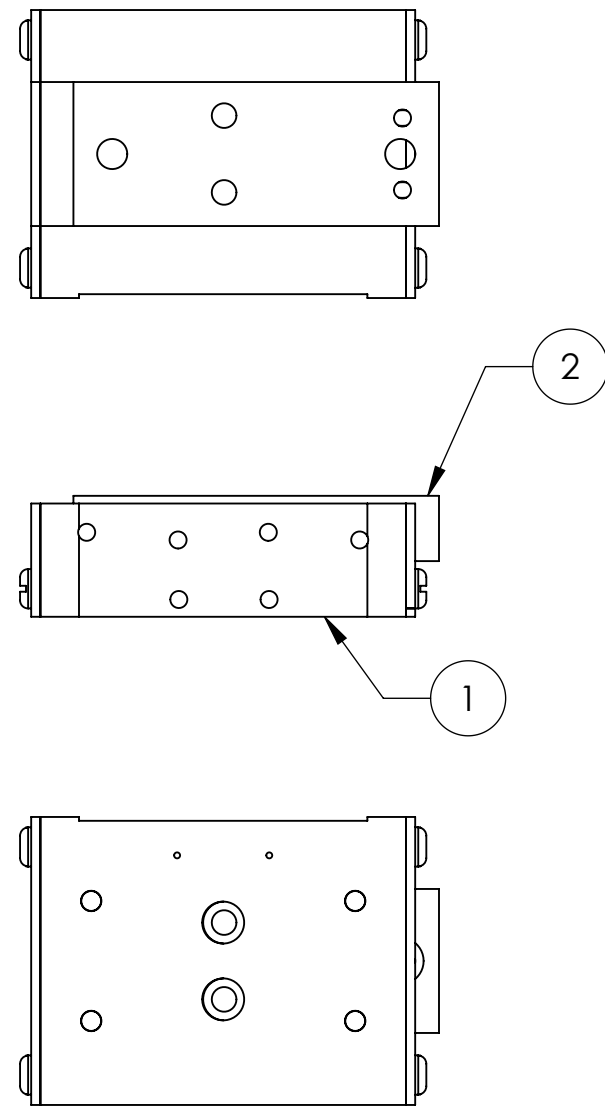

ITEM NO.	PART NUMBER	DESCRIPTION	QTY.
1	D1001947-v2	aLIGO TMS DEL-TRON RS1-1 HOR. CARRIAGE	1
2	D1001948-v3	aLIGO TMS DEL-TRON-RS1-1-GUIDE	1

① MODIFY DEL-TRON RS1-1 SLIDE ASSEMBLY.

NOTES AND TOLERANCES: (UNLESS OTHERWISE SPECIFIED)

DIMENSIONS ARE IN INCHES

TOLERANCES:
 .XX ± .03
 .XXX ± .005
 ANGULAR ± °

1. INTERPRET DRAWING PER ASME Y14.5-1994.
 2. REMOVE ALL SHARP EDGES, R.02 MIN.
 3. DO NOT SCALE FROM DRAWING.
 4. ALL MACHINING FLUIDS MUST BE FULLY SYNTHETIC, FULLY WATER SOLUBLE AND FREE OF SULFUR, SILICONE, AND CHLORINE.

MATERIAL **FINISH** N/A μinch

SYSTEM LIGO **SUB-SYSTEM** AOS **PART NAME** aLIGO TMS DEL-TRON-RS1 HORIZ. SLIDE ASSY

DESIGNER K. MAILLAND 17 JUL 2010 **SIZE** B **DWG. NO.** D1001892 **REV.** v2
DRAFTER M. MILLER 07/26/2010
CHECKER
APPROVAL

SCALE: 2:1 **PROJECTION:** **SHEET 1 OF 1**