

8 7 6 5 4 3 2 1

- NOTES CONTINUED:
- 5 BAG AND TAG PARTS WITH THEIR DRAWING PART NUMBER, REVISION, VARIANT OR "TYPE" (IF APPLICABLE), AND QUANTITY. IF PARTS ARE TOO SMALL TO SCRIBE, BAGGING AND TAGGING ALONE IS SUFFICIENT. EXAMPLE (TAG): DXXXXXX-VY, TYPE-XX, QTY: TBD
 - 6 APPROXIMATE WEIGHT = .01 LB [3G]
 - 7 ALL PARTS TO BE MANUFACTURED IN ACCORDANCE WITH LIGO SPECIFICATION E0900364.
 - 8 ALL MATERIAL IS TO BE VIRGIN MATERIAL (i.e. NOT WELD REPAIRS OR PLUGS UNLESS APPROVED IN ADVANCE IN WRITING BY LIGO, REFER TO LIGO-E0900364.
 - 9 NO REPAIRS SHALL BE MADE UNLESS APPROVED IN ADVANCE, AND IN WRITING, BY LIGO LABORATORY. IN GENERAL WELD REPAIRS AND PRESS FIT INSERT REPAIRS ARE NEVER ACCEPTABLE; THE MATERIAL SHOULD BE MADE WITH VIRGIN MATERIAL. SPECIAL CIRCUMSTANCES CAN BE REVIEWED IF / WHEN BROUGHT TO THE ATTENTION OF LIGO CONTRACTING OFFICER'S REPRESENTATIVE (COTR) THROUGH A MATERIAL REVIEW BOARD (MRB) PROCESS, REFER TO LIGO-E0900364.
 - 10 MCMASTER CARR# 9011K92, ASTM 304 SHIM STOCK .020 X 8" X 12", FULL HARD, FROM TRINITY BRAND INDUSTRIES.
 - 11 OR EQUIVALENT. ELECTROPOLISH PER LIGO SPECIFICATION E0900364, SECTION 5.2.2.

REV.	DATE	DCN #	DRAWING TREE #
v1	08/12/2010	E1000318	-
v2	10/29/2010	E1000602	-
v3	11/12/2010	E1000689	-

D1001841 aLIGO TMS FOCUS SLIDE LOCK., PART PDM REV: X-027, DRAWING PDM REV: X-027

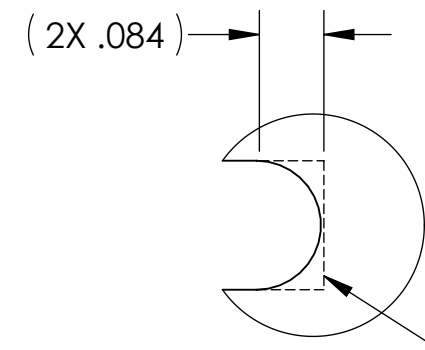
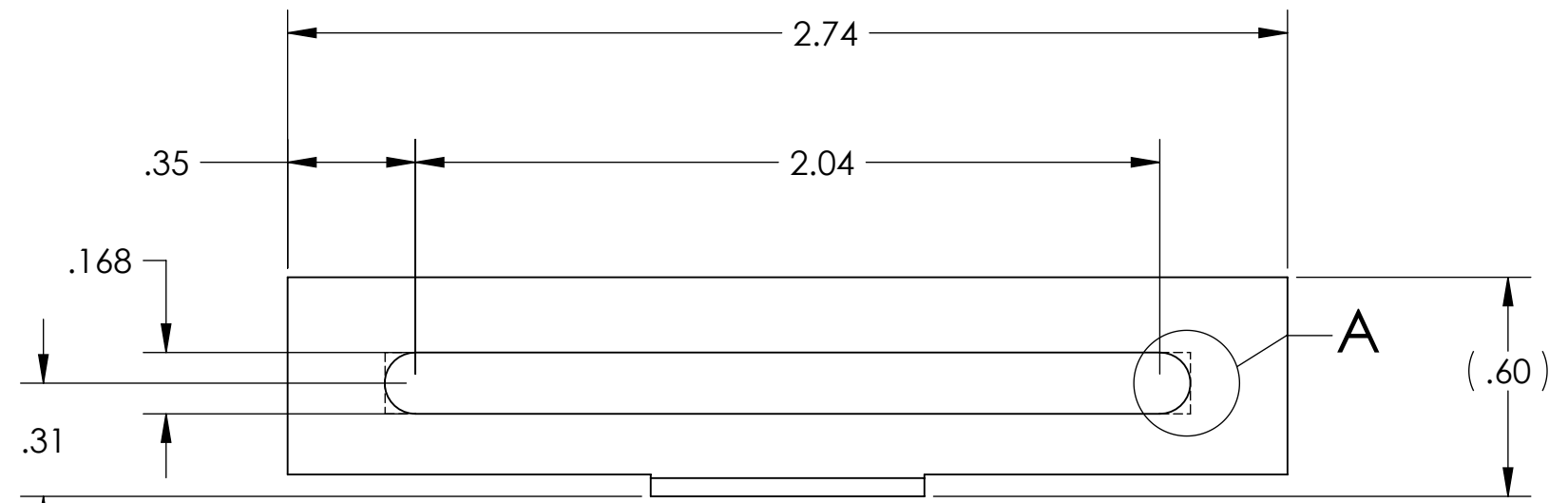

DETAIL A
SCALE 4 : 1
2X REF: SQUARE END
OPTIONAL

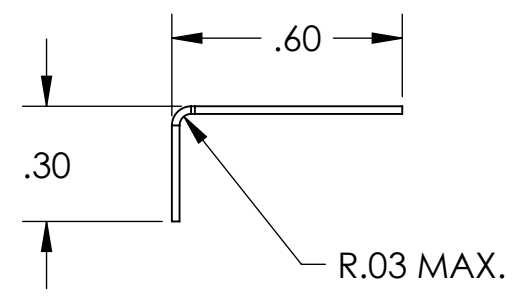
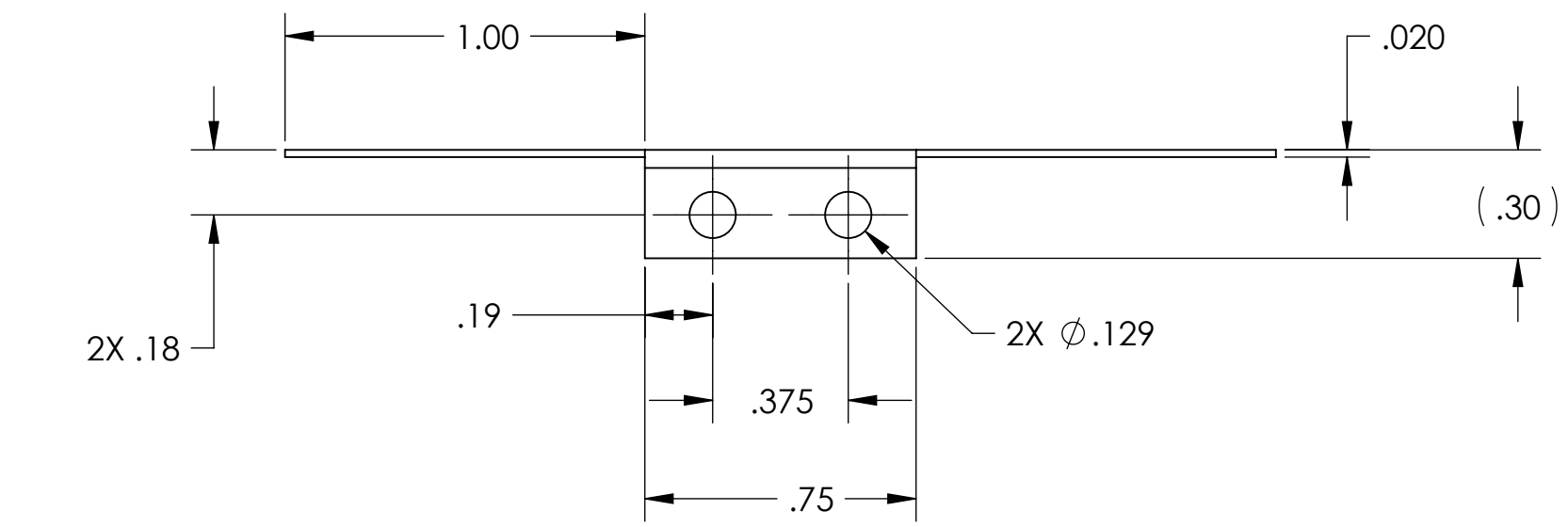
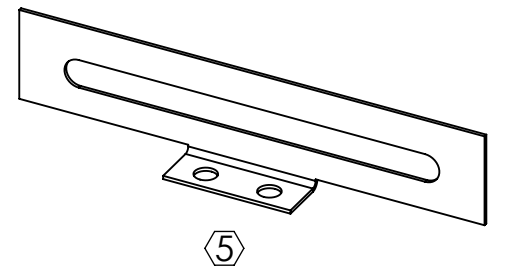

NOTES AND TOLERANCES: (UNLESS OTHERWISE SPECIFIED)				LIGO CALIFORNIA INSTITUTE OF TECHNOLOGY MASSACHUSETTS INSTITUTE OF TECHNOLOGY		PART NAME	
DIMENSIONS ARE IN INCHES TOLERANCES: .XX ± .01 .XXX ± .005 ANGULAR ± 1.0°				1. INTERPRET DRAWING PER ASME Y14.5-1994. 2. REMOVE ALL SHARP EDGES, R.02 MIN. 3. DO NOT SCALE FROM DRAWING. 4. ALL MACHINING FLUIDS MUST BE FULLY SYNTHETIC, FULLY WATER SOLUBLE AND FREE OF SULFUR, SILICONE, AND CHLORINE.		aLIGO TMS FOCUS SLIDE LOCK	
MATERIAL 10		FINISH 32 μinch Ra 11		SYSTEM LIGO SUB-SYSTEM AOS		DESIGNER K. MAILAND 07/28/2010 DRAFTER M. MILLER 07/22/2010	
NEXT ASSY D1001600				CHECKER		SIZE DWG. NO. B D1001841 REV. v3	
				APPROVAL		SCALE: 2:1 PROJECTION: SHEET 1 OF 1	

8 7 6 5 4 3 2 1