

REV.	DATE	DCN #	DRAWING TREE #
v1	04-AUG-2010	E1000291	E1000295-v1
-	-	-	-
-	-	-	-

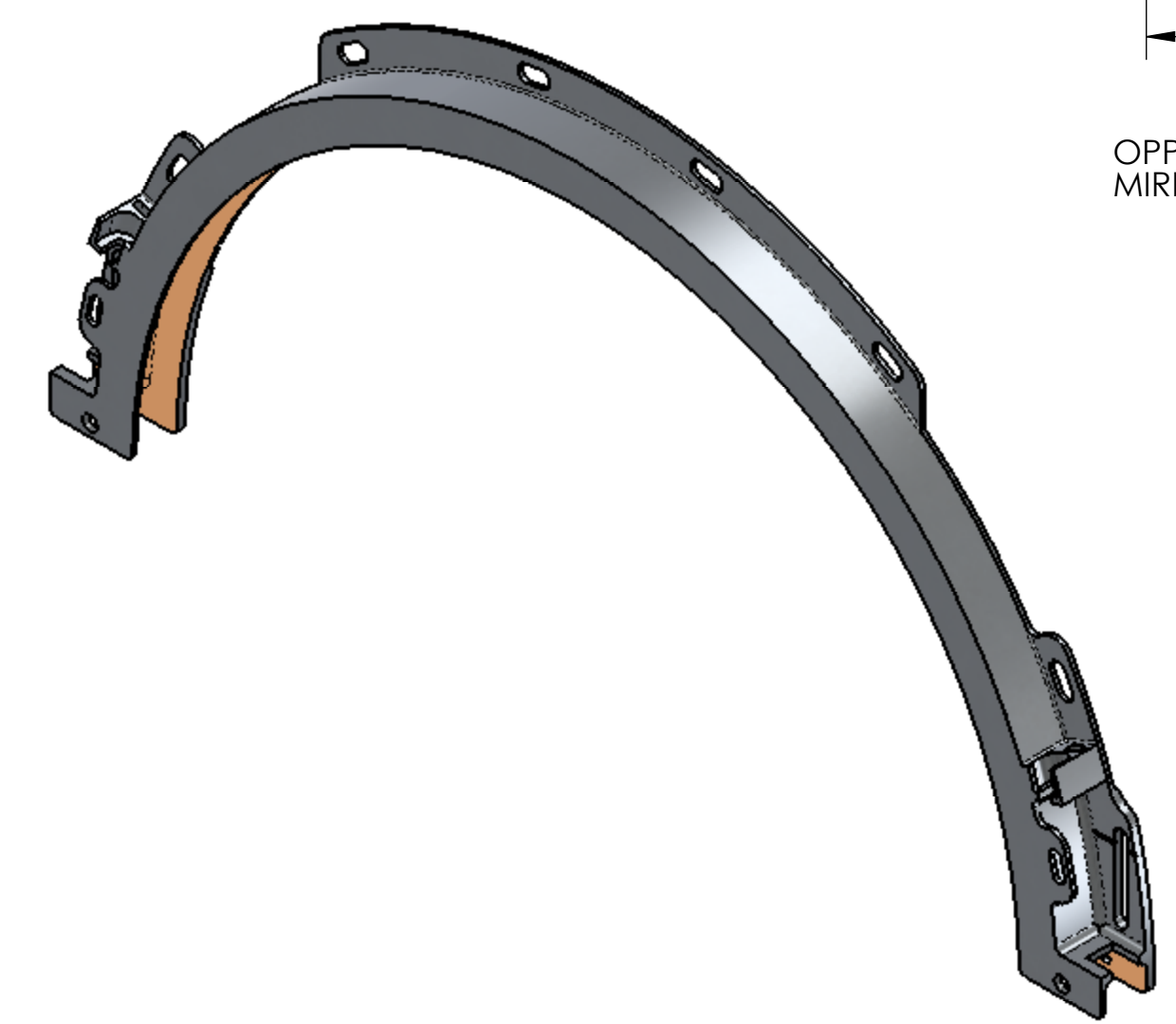
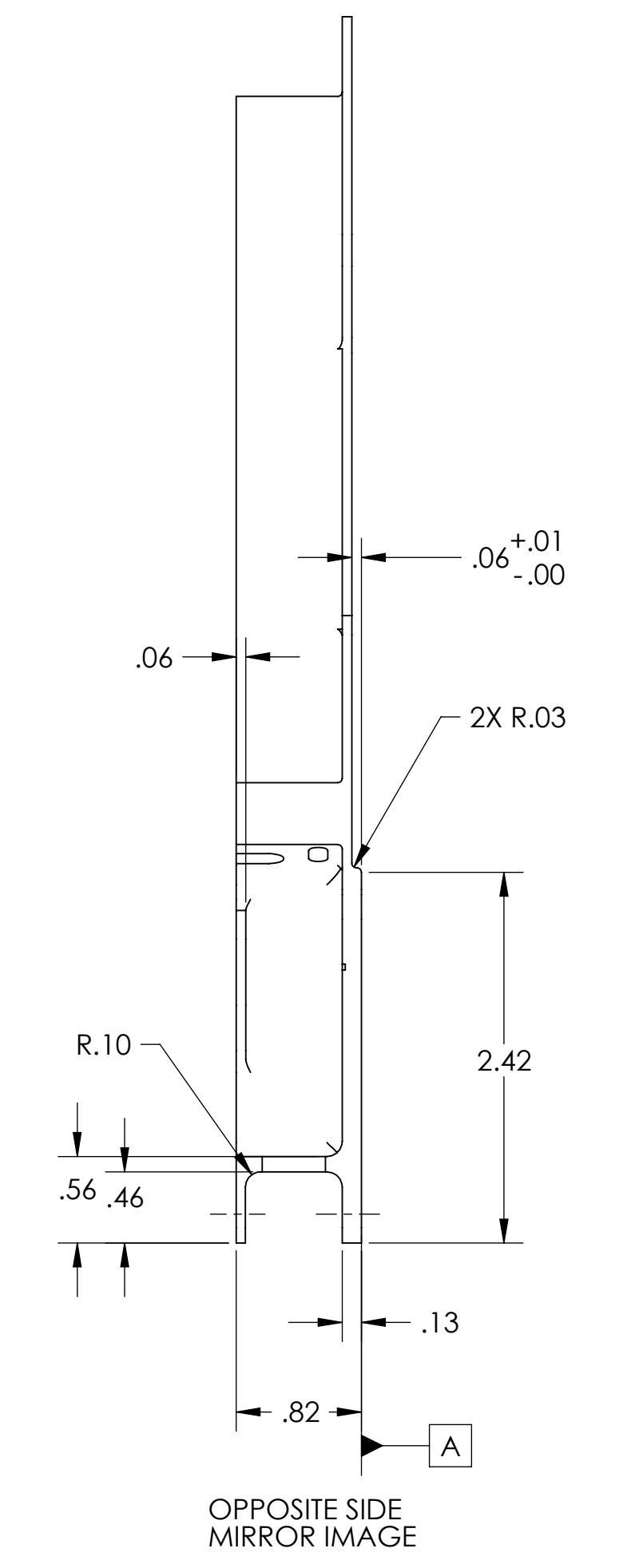

D1001679_ALIGO TCS UPPER MONOLITHIC RH SHIELD PART PDM REV: X020 DRAWING PDM REV: X009

NOTES AND TOLERANCES: (UNLESS OTHERWISE SPECIFIED)	
DIMENSIONS ARE IN INCHES	
TOLERANCES: .XX ± .01 .XXX ± .005	
ANGULAR ± 0.5°	
MATERIAL	FINISH
6061 Alloy	32 μinch

CALIFORNIA INSTITUTE OF TECHNOLOGY MASSACHUSETTS INSTITUTE OF TECHNOLOGY	SYSTEM	SUB-SYSTEM
	ADVANCED LIGO	AOS
NEXT ASSY	D1001838	

PART NAME			
ALIGO TCS UPPER MONOLITHIC RH SHIELD			
DESIGNER	M. JACOBSON	21 APR 2010	SIZE DWG. NO.
DRAFTER	A. COLE	7/13/2010	D D1001679
CHECKER	C. TORRIE	07/19/2010	REV. v1
APPROVAL	P. WILLEMS	7/13/2010	SCALE: 1:2 PROJECTION: SHEET 1 OF 2

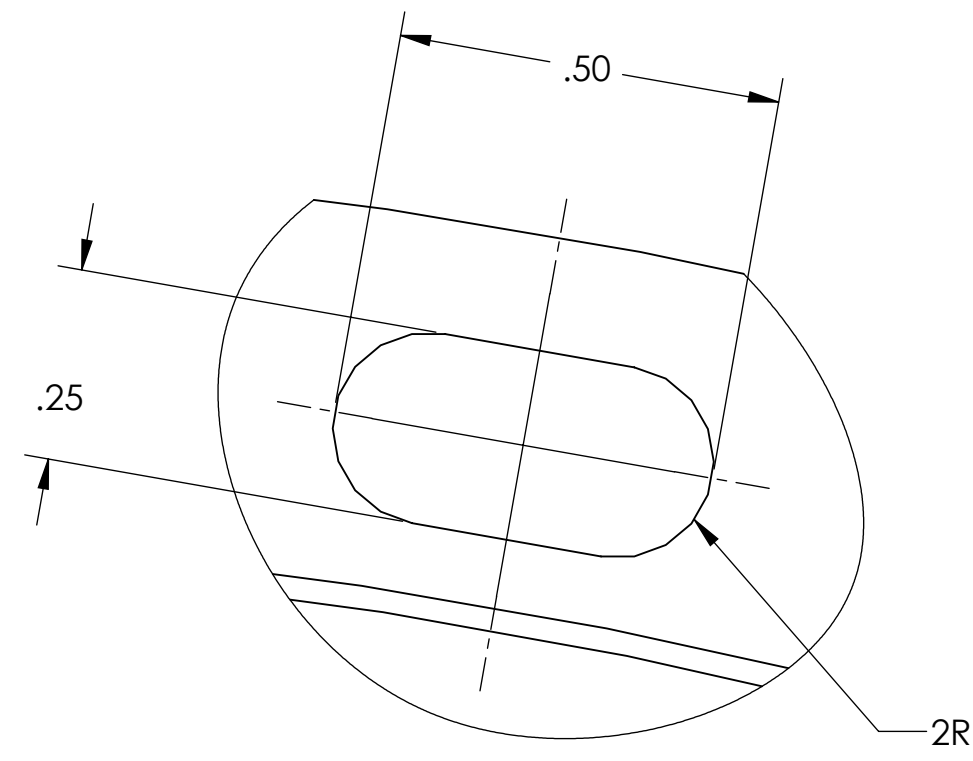

6X
DETAIL A
SCALE 4 : 1

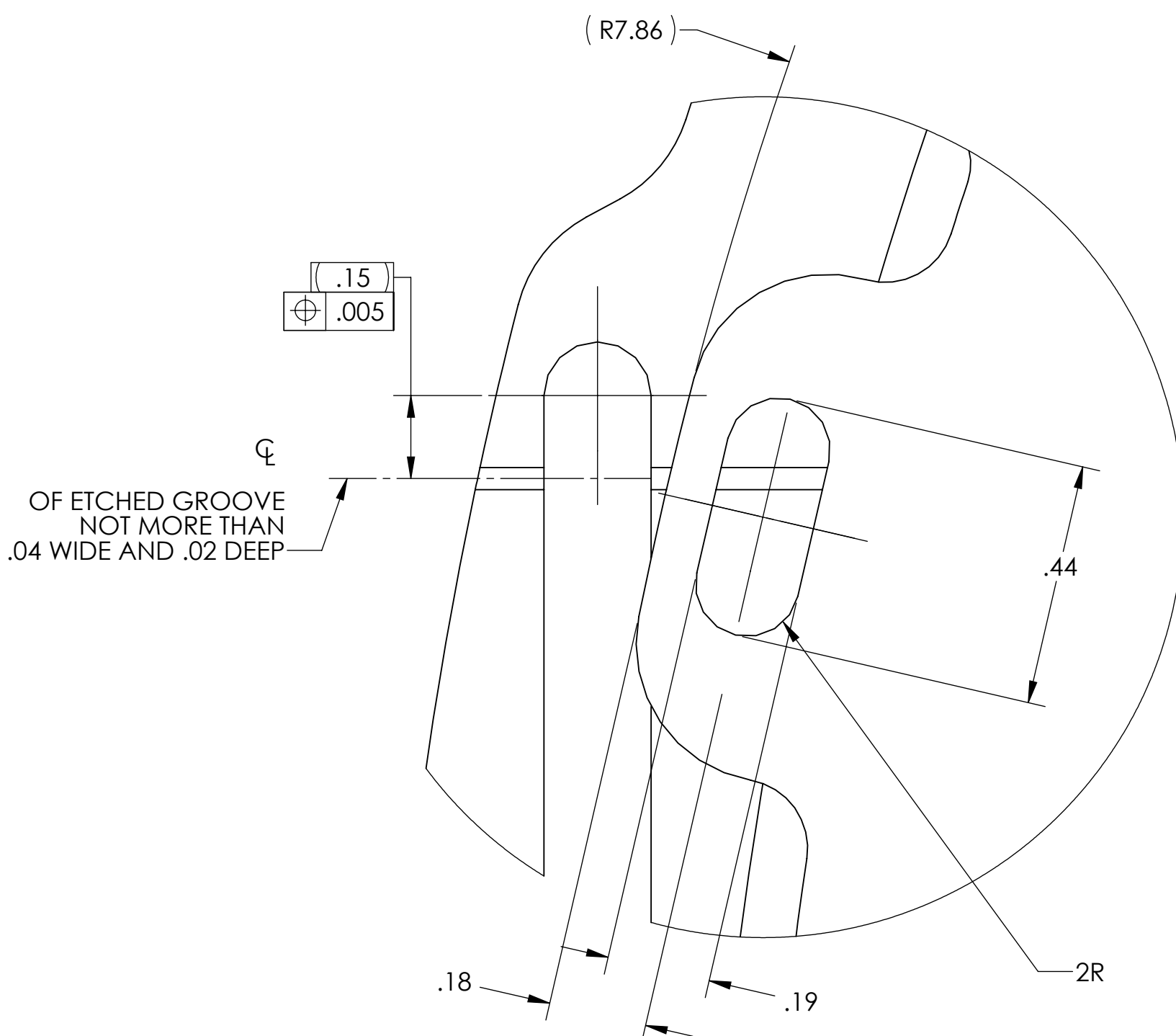

2X
DETAIL B
SCALE 4 : 1

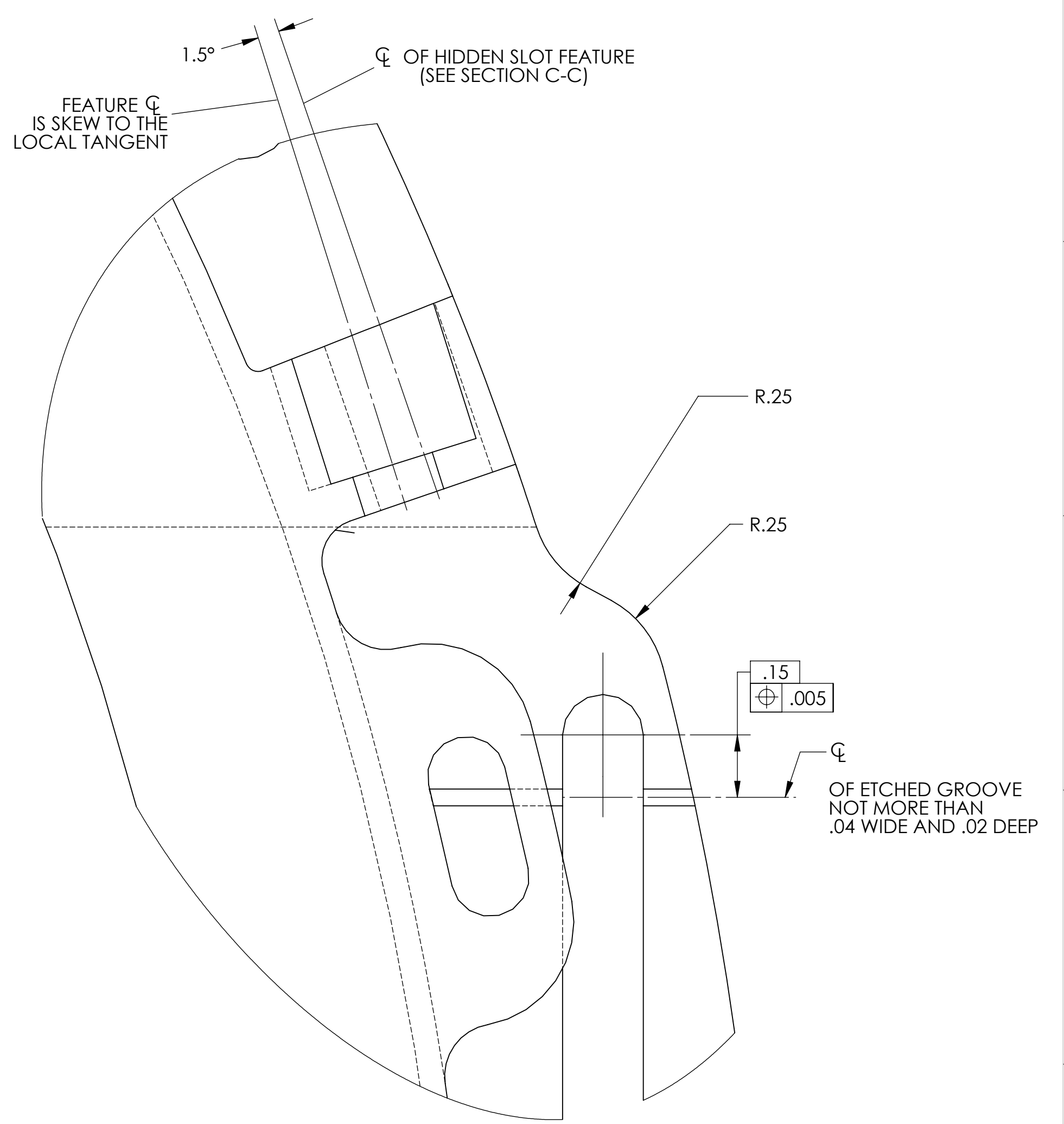

2X
DETAIL D
SCALE 4 : 1

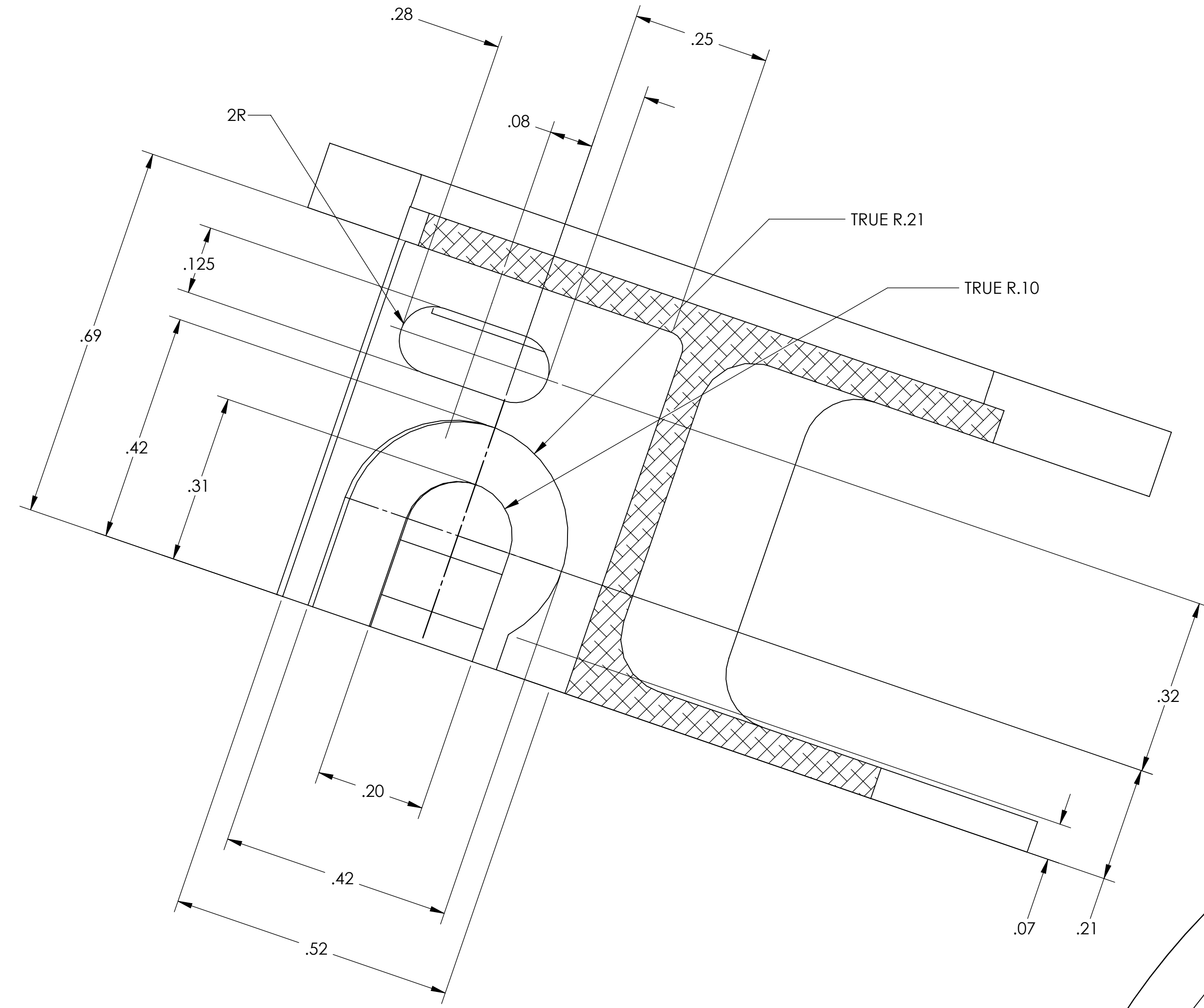

2X
SECTION C-C
SCALE 6 : 1

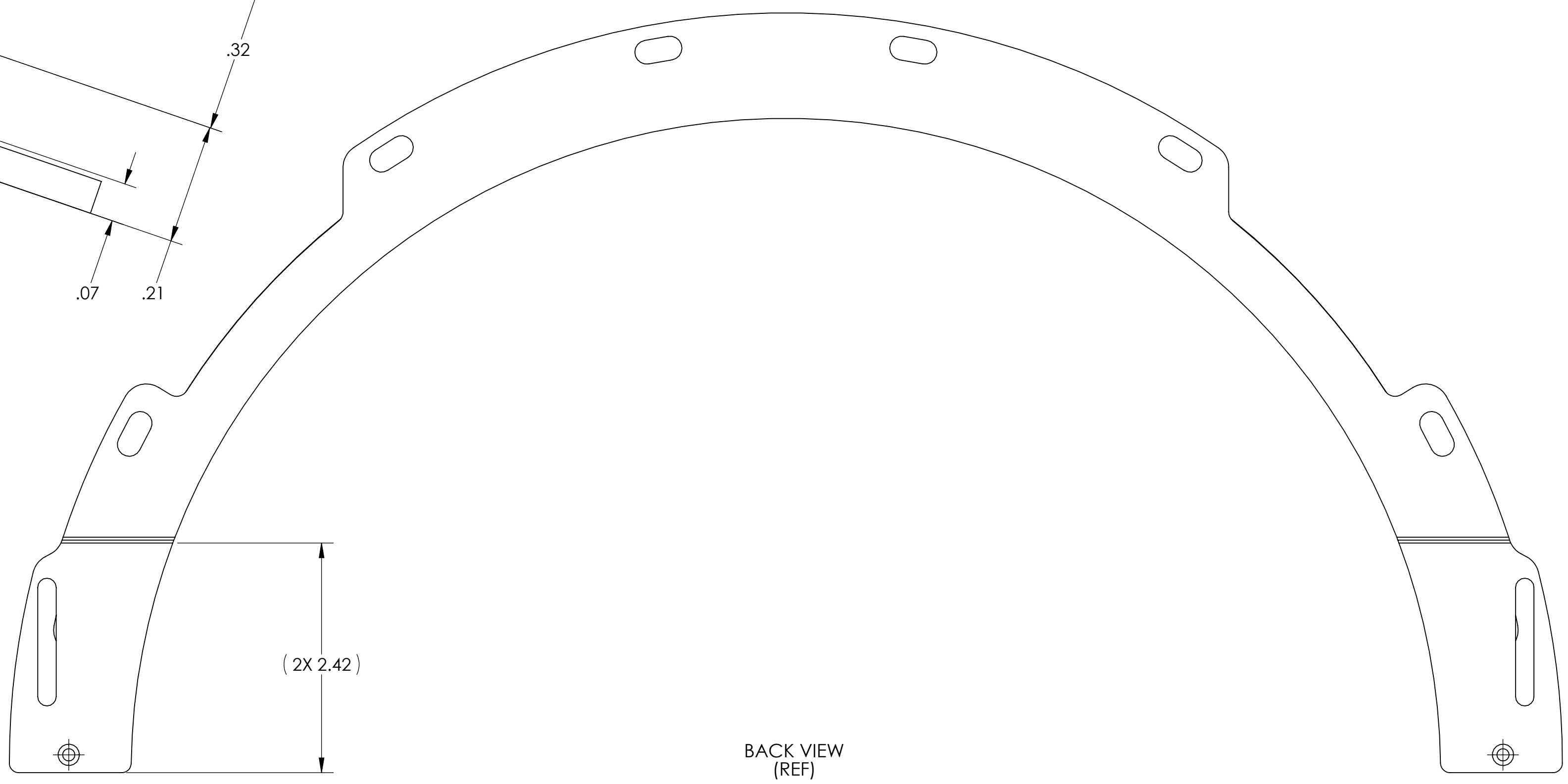

BACK VIEW
(REF)

LIGO CALIFORNIA INSTITUTE OF TECHNOLOGY
MASSACHUSETTS INSTITUTE OF TECHNOLOGY

SIZE	DWG. NO.	REV.
D	D1001679	v1
SCALE: 1:2	PROJECTION:	SHEET 2 OF 2

D1001679_ALIGO_TCS_UPPER_MONOLITHIC_RING_HEATER_SHIELD_PART_PDM_REV.X200_DRAWING_PDM_REV.X200