

REV.	DATE	DCN #	DRAWING TREE #
A	28 MAR 2008	E080113-00	
B	17 Apr 08	E080169-00	

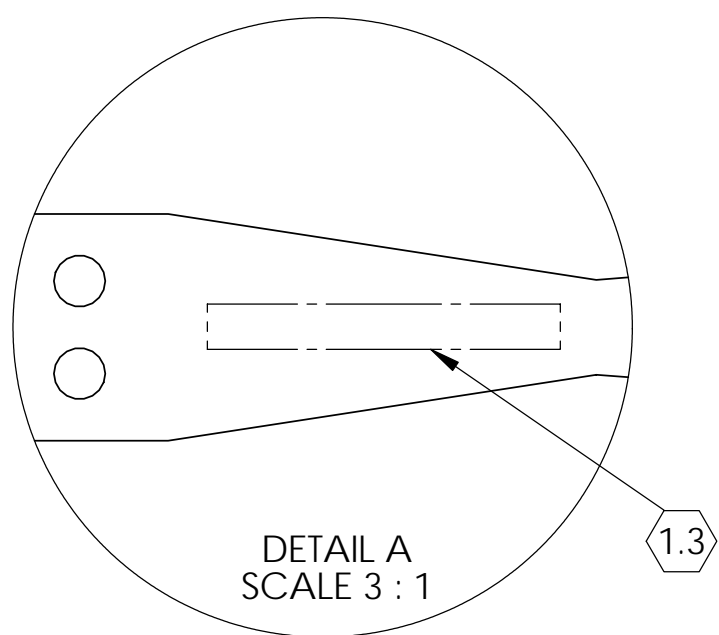
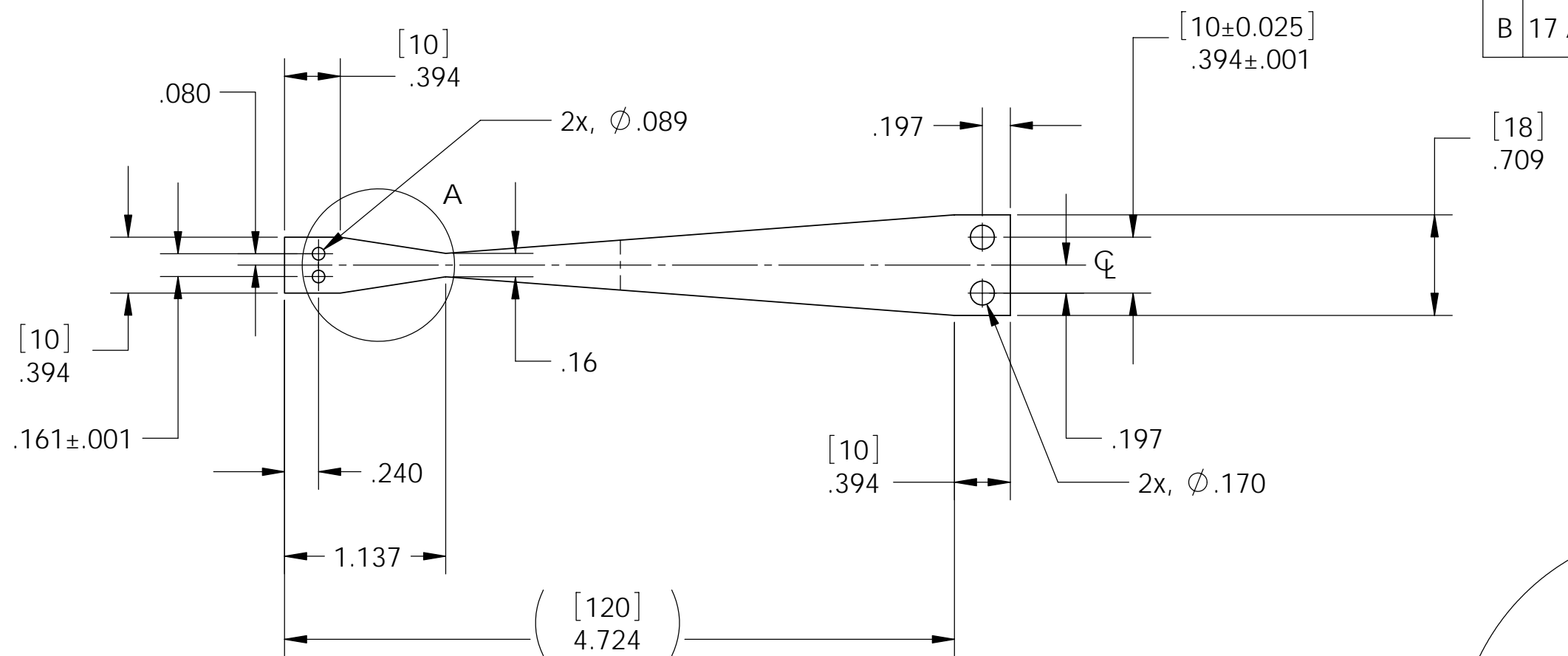

MANUFACTURING NOTES: (UNLESS OTHERWISE SPECIFIED)

- REMOVE ALL SHARP EDGES, R.02 MIN.
- ALL MACHINING FLUIDS SHALL BE WATER SOLUBLE AND FREE OF SULFUR, CHLORINE AND SILICONE, SUCH AS CINCINNATI MILACRON'S CIMTECH 410 (SSTL).
- ENGRAVE OR STAMP DRAWING PART NUMBER ON NOTED SURFACE OF PART AND A THREE DIGIT SERIAL NUMBER. SERIAL NUMBERS START AT 001 FOR THE FIRST PART AND PROCEED CONSECUTIVELY. USE .07" HIGH CHARACTERS. EXAMPLE: D020188-001. A VIBRATORY TOOL MAY BE USED.
- SHEET 1 OF 2 SHOWS VIEWS PRIOR TO FORMING.
- AFTER FORMING THE BLADES ARE ANNEALED AT 435°C FOR 100 HOURS.
- SHEET 2 OF 2 VIEWS ARE SHOWN AFTER FORMING & ANNEALING.
- AS SHOWN IN SHEET 2 OF 2, THE RADIUS OF CURVATURE IS THE INTERNAL RADIUS.
- AS SHOWN, THE OVERALL DEFLECTION IS MEASURED FROM THE BOTTOM OF THE BASE POINT TO THE HIGHEST POINT ON THE TIP OF THE BLADE.

OTHER NOTES (FOR INTERNAL USE)

- SHAPE FACTOR FOR LOWER BLADE = 1.54
- LOAD ON LOWER BLADE (FLAT) = 1.725 kg
- PREDICTED UNCOUPLED FREQUENCY = 2.15 Hz
- PREDICTED FIRST INTERNAL MODE = 260 Hz.
- MAXIMUM STRESS = 677 MPa
- SOLIDWORKS RADIUS VALUE OVER WRITTEN, WITH VALUE CALCULATED BY MVP.
- IN SW PART, BLADE MUST BE DRAWN WITH SHEET METAL AND EXTRUDED VERTICALLY DOWNWARDS.
- IN SW PART RADIUS SHOULD BE ADJUSTED TO ATTAIN DESIRED LENGTH ON DRAWING SHEET.

DUAL DIMENSIONS [mm] INCHES
 TOLERANCES:
 .XX ±.01
 .XXX ±.005
 ANGULAR ± 0.5°

MATERIAL MARAGING STEEL C250		
FINISH		
NAME	DATE	
DRAWN C TORRIE	JAN 2008	
CHECKED B KIRSNER	JAN 2008	
APPROVED		

LIGO CALIFORNIA INSTITUTE OF TECHNOLOGY
 MASSACHUSETTS INSTITUTE OF TECHNOLOGY
 IGR, GLASGOW UNIVERSITY GEO 600 GROUP

SYSTEM **ADVANCED LIGO**

SUB-SYSTEM **SUS**

NEXT ASSY **OMC: UPPER MASS**

PART NAME **LOWER BLADE (LHO)**

SIZE **B** DWG. NO. **D080019** REV. **B**

SCALE: NTS PROJECTION: SHEET 1 OF 2

FILE NAME/LOCATION: 1

8 7 6 5 4 3 2 1

REV.	DATE	DCN #	DRAWING TREE #

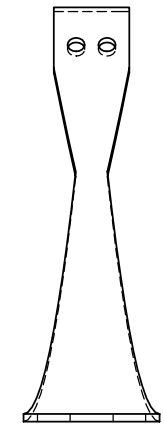
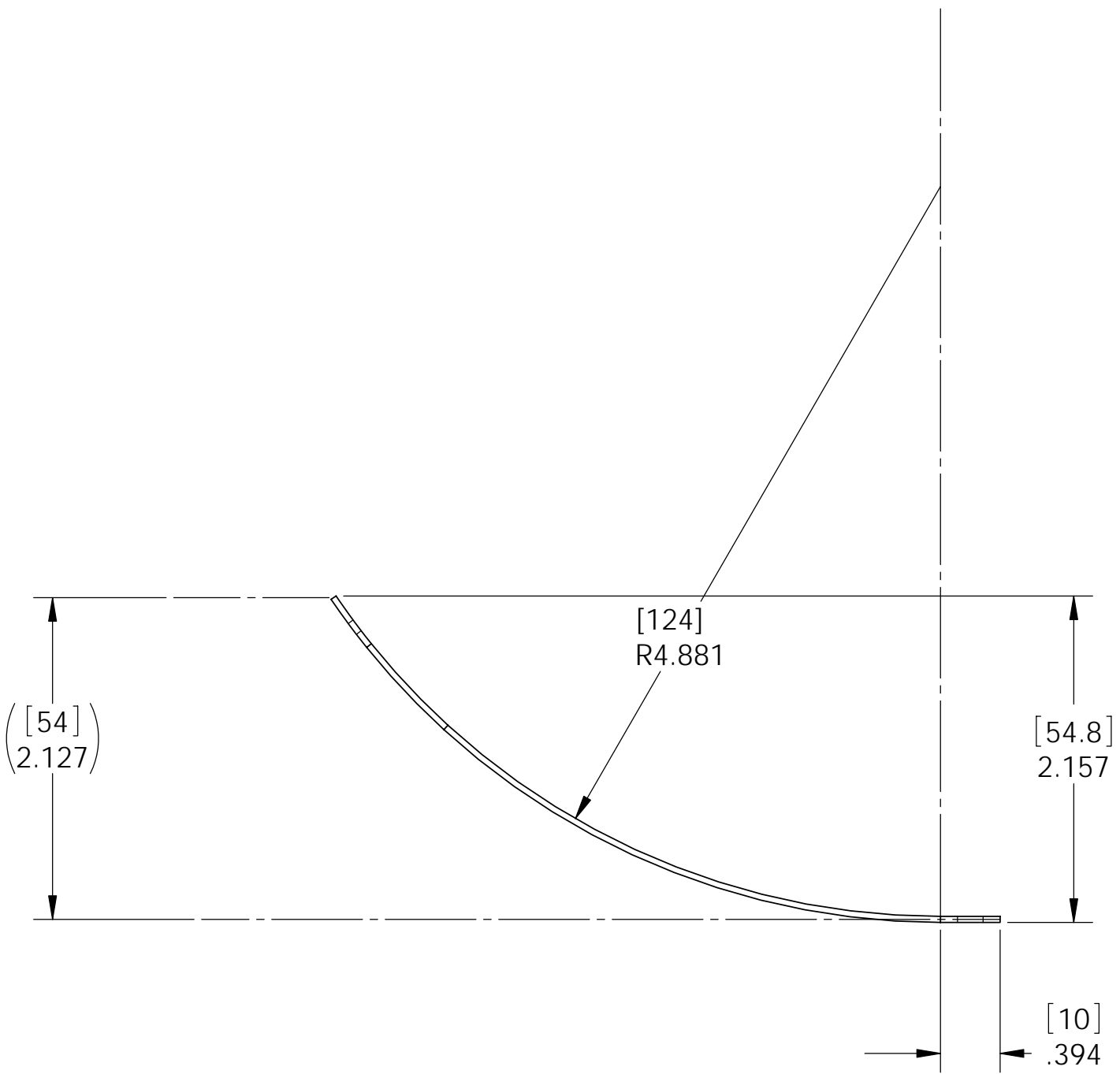
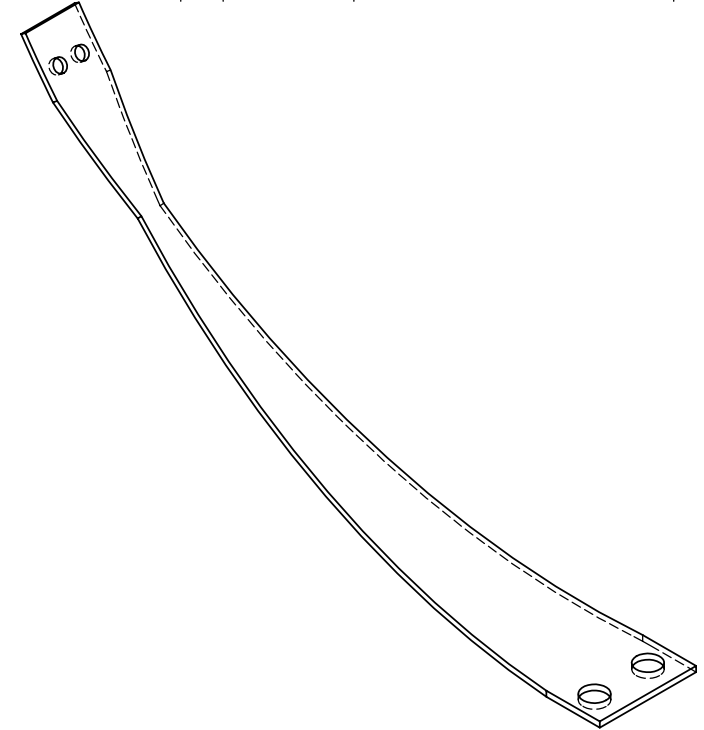
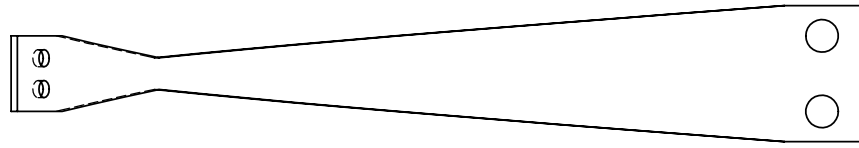

D
C
B
A

D
C
B
A

LIGO CALIFORNIA INSTITUTE OF TECHNOLOGY
 MASSACHUSETTS INSTITUTE OF TECHNOLOGY
 IGR, GLASGOW UNIVERSITY GEO 600 GROUP

SYSTEM	ADVANCED LIGO	
SUB-SYSTEM	SUS	
NEXT ASSY	OMC: UPPER MASS	
PART NAME	LOWER BLADE (LHO)	
SIZE	DWG. NO.	REV.
B	D080019	B
SCALE: NTS	PROJECTION:	SHEET 2 OF 2

FILE NAME/LOCATION: 1

7 6 5 4 3 2 1