

REV.	DATE	DCN #	DRAWING TREE #
A	28 MAR 2008	E080113-00	
B	17 APR 08	E080169-00	
C	24 APR 08	E080179-00	

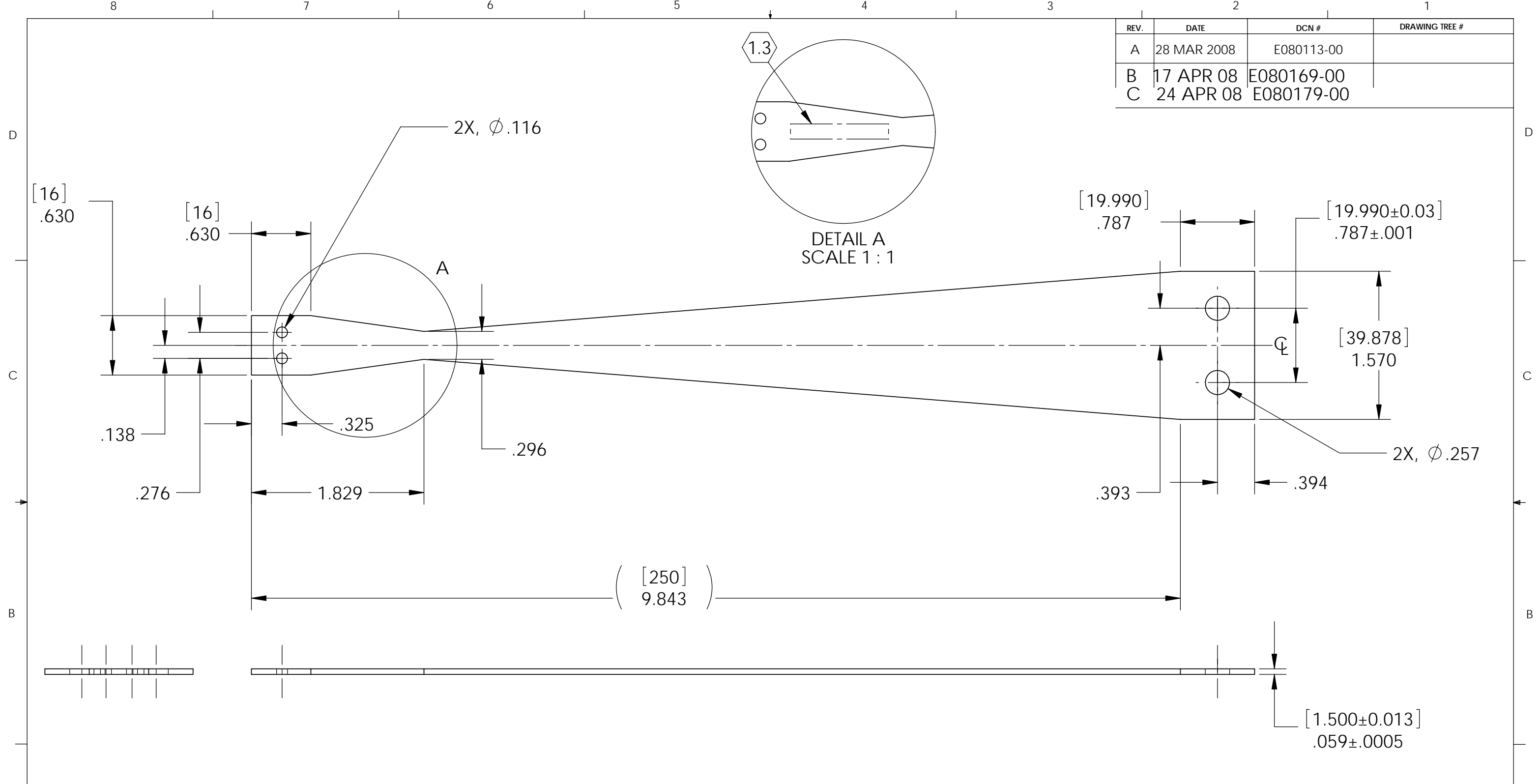

**MANUFACTURING NOTES: (UNLESS OTHERWISE SPECIFIED)**

1.1 REMOVE ALL SHARP EDGES, R.02 MIN.

1.2 ALL MACHINING FLUIDS SHALL BE WATER SOLUBLE AND FREE OF SULFUR, CHLORINE AND SILICONE, SUCH AS CINCINNATI MILACRON'S CIMTECH 410 (SSTL).

1.3 ENGRAVE OR STAMP DRAWING PART NUMBER ON NOTED SURFACE OF PART AND A THREE DIGIT SERIAL NUMBER. SERIAL NUMBERS START AT 001 FOR THE FIRST PART AND PROCEED CONSECUTIVELY. USE .07" HIGH CHARACTERS. EXAMPLE: D020188- 001. A VIBRATORY TOOL MAY BE USED.

1.4 SHEET 1 OF 2 SHOWS VIEWS PRIOR TO FORMING.

1.5 AFTER FORMING, HEAT TREAT AT 435°C FOR 100 HOURS.

1.6 SHEET 2 OF 2 VIEWS ARE SHOWN AFTER FORMING & ANNEALING.

1.7 AS SHOWN IN SHEET 2 OF 2, THE RADIUS OF CURVATURE IS THE INTERNAL RADIUS.

1.8 AS SHOWN, THE OVERALL DEFLECTION IS MEASURED FROM THE BOTTOM OF THE BASE POINT TO THE HIGHEST POINT ON THE TIP OF THE BLADE.

**OTHER NOTES (FOR INTERNAL USE)**

2.1 SHAPE FACTOR FOR LOWER BLADE = 1.32

2.2 LOAD ON LOWER BLADE (FLAT) = 4 . 829 kg

2.3 PREDICTED UNCOUPLED FREQUENCY = 2 . 36 Hz

2.4 PREDICTED FIRST INTERNAL MODE = 90 Hz.

2.5 MAXIMUM STRESS = 789 MPa

2.6 SOLIDWORKS RADIUS VALUE OVER WRITTEN, WITH VALUE CALCULATED BY MVP.

2.7 IN SW PART, BLADE MUST BE DRAWN WITH SHEET METAL AND EXTRUDED VERTICALLY DOWNWARDS.

2.8 IN SW PART RADIUS SHOULD BE ADJUSTED TO ATTAIN DESIRED LENGTH ON DRAWING SHEET.

DIMENSIONS ARE IN INCHES

TOLERANCES:  
 .XX ± .01  
 .XXX ± .005

ANGULAR ± 0.5°

MATERIAL  
 MARAGING STEEL C250

FINISH

	NAME	DATE
DRAWN	C TORRIE	JAN 2008
CHECKED	B KIRSNER	JAN 2008
APPROVED		

**LIGO** CALIFORNIA INSTITUTE OF TECHNOLOGY  
 MASSACHUSETTS INSTITUTE OF TECHNOLOGY  
 IGR, GLASGOW UNIVERSITY GEO 600 GROUP

SYSTEM **ADVANCED LIGO**

SUB-SYSTEM **SUS**

NEXT ASSY **OMC UPPER BLADES**

PART NAME **UPPER BLADE (LHO)**

SIZE	DWG. NO.	REV.
<b>B</b>	<b>D080018</b>	<b>C</b>

SCALE: NTS PROJECTION: SHEET 1 OF 2

REV.	DATE	DCN #	DRAWING TREE #

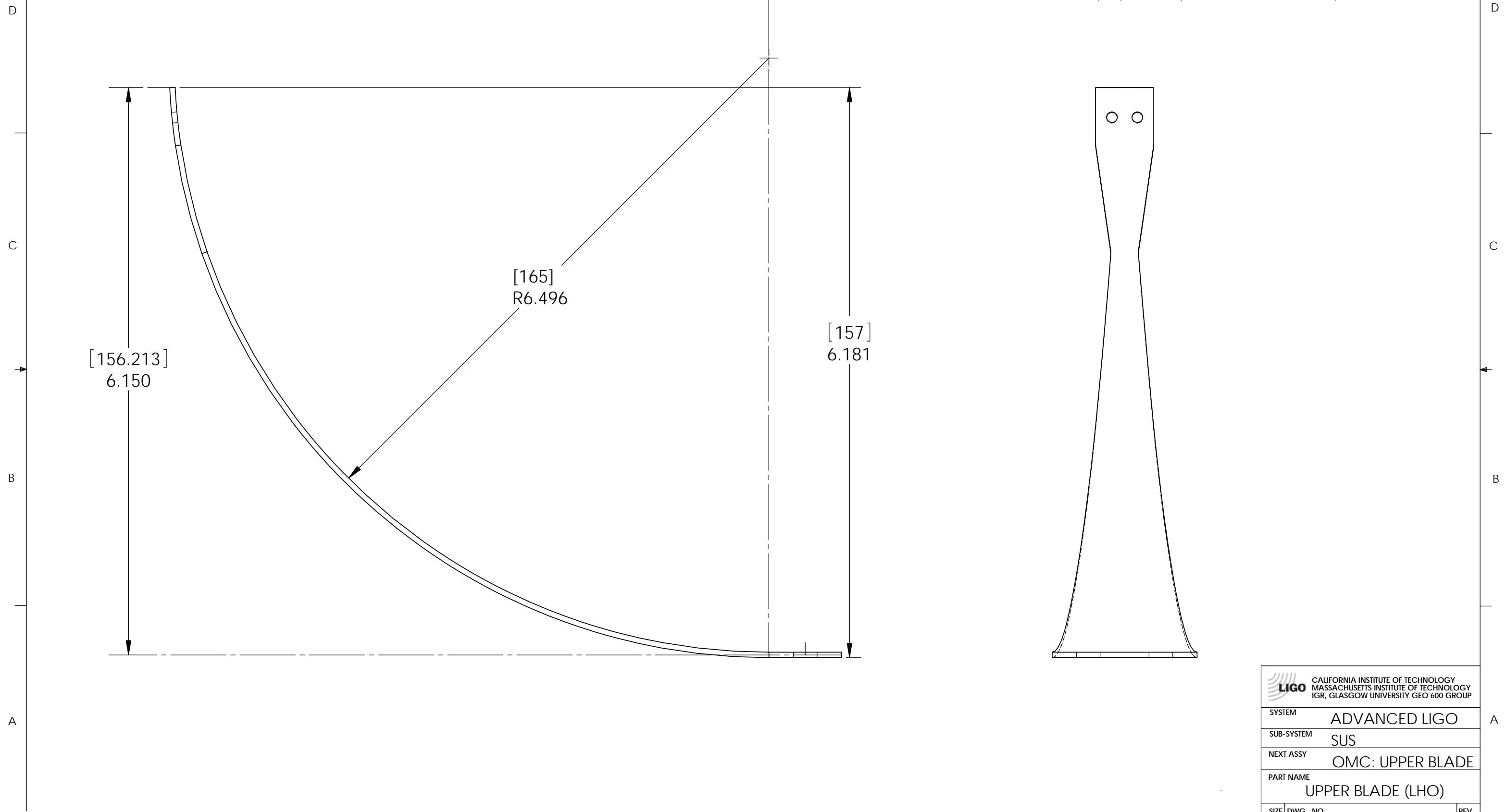

 CALIFORNIA INSTITUTE OF TECHNOLOGY MASSACHUSETTS INSTITUTE OF TECHNOLOGY IGR, GLASGOW UNIVERSITY GEO 600 GROUP		
SYSTEM	ADVANCED LIGO	
SUB-SYSTEM	SUS	
NEXT ASSY	OMC: UPPER BLADE	
PART NAME	UPPER BLADE (LHO)	
SIZE	DWG. NO.	REV.
B	D080018	C
SCALE: NTS	PROJECTION:	SHEET 2 OF 2

FILE NAME/LOCATION: 1