

BC19G7CBHBI 98.

G7 F 69Z9B: F5J 9Z@5G9F A 5F? CF:
A 97 <5B=75@MG5A Dfbc 8M9GCF B?G:5
1 B E I 9HkF998= HG9F 5@BI A 69F / F9J GcB
BI A 69F CB 957 < D5FHG9F 5@BI A 69FGG5FH
5H\$\$%: CF H:9: FGH5FH7 @5B8 DFC 7 998
7 C B G 7 I H J 9 @ M 6 5 : 5 B 8 H 5 : D 5 F H G K H H 9 F
8 F 5 K B : D 5 F H B I A 6 9 F Z F 9 J G C B Z J 5 F 5 B H C F
HMD9 Fh 5DD@7 56@Z5B8 E I 5BHMM 5 D5FHG
5F9HC CA 5@HC G7 F 69Z65: : B: 5B8
H5: : B: 5@B9GQ : : 7 9BH
9L5A D@7D5FHL \$\$%j %
9L5A D@7H5: E 8LLLLLLLLIJ M HMD9LLZE HMH8

*.....5DDFCLA 5H9K 9= <H G99: 9@8 C: 8F5K B: "
+.....5@<9@47 C @<C @9GHC 69DF9D5F98 57 7 CF8B: HC
.....9A <5FH<9@47 C @DFC 8I 7 H 7 5 H 5 @C: Z <7 &\$\$ZF9J ("

.....5@<9@47 C @B G9FHGHC 69 B G 5 @98 6M@: C D9FGC BB9@
.....5: H9F 89@J 9FMC: : B G < 98 D5FHGZ I G9B #FC B 7 * \$ H F 95898 B G9FHG

Table with 4 columns: F9J", 85H9, 87B', 8F5K B; 'H99'. Rows include j %, j &, j ' with associated symbols and values.

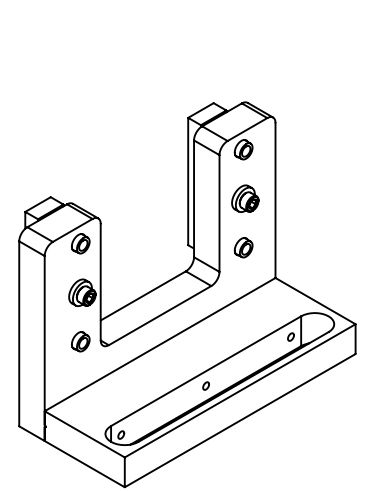

8%\$\$% (+!%
K 9= <H" "" @6G

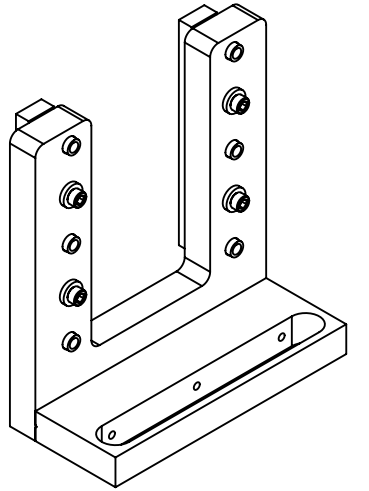

8%\$\$% (+!&
K 9= <H" (%) @6G

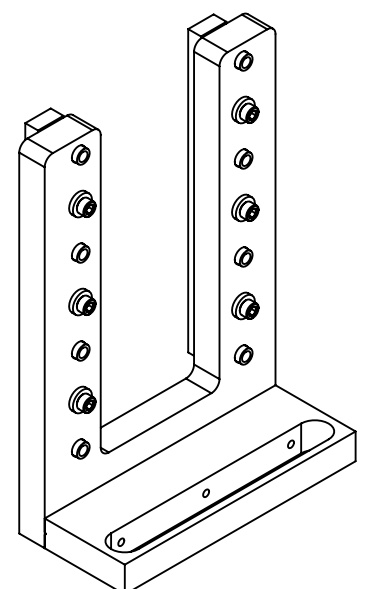

8%\$\$% (+!
K 9= <H" (\$) @6G

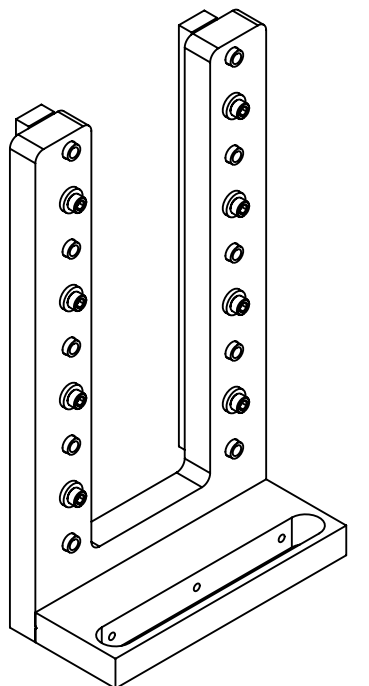

8%\$\$% (+(
K 9= <H") @6G

F9: 9F9B7 9J 9K G
G7 5 @. BC B9

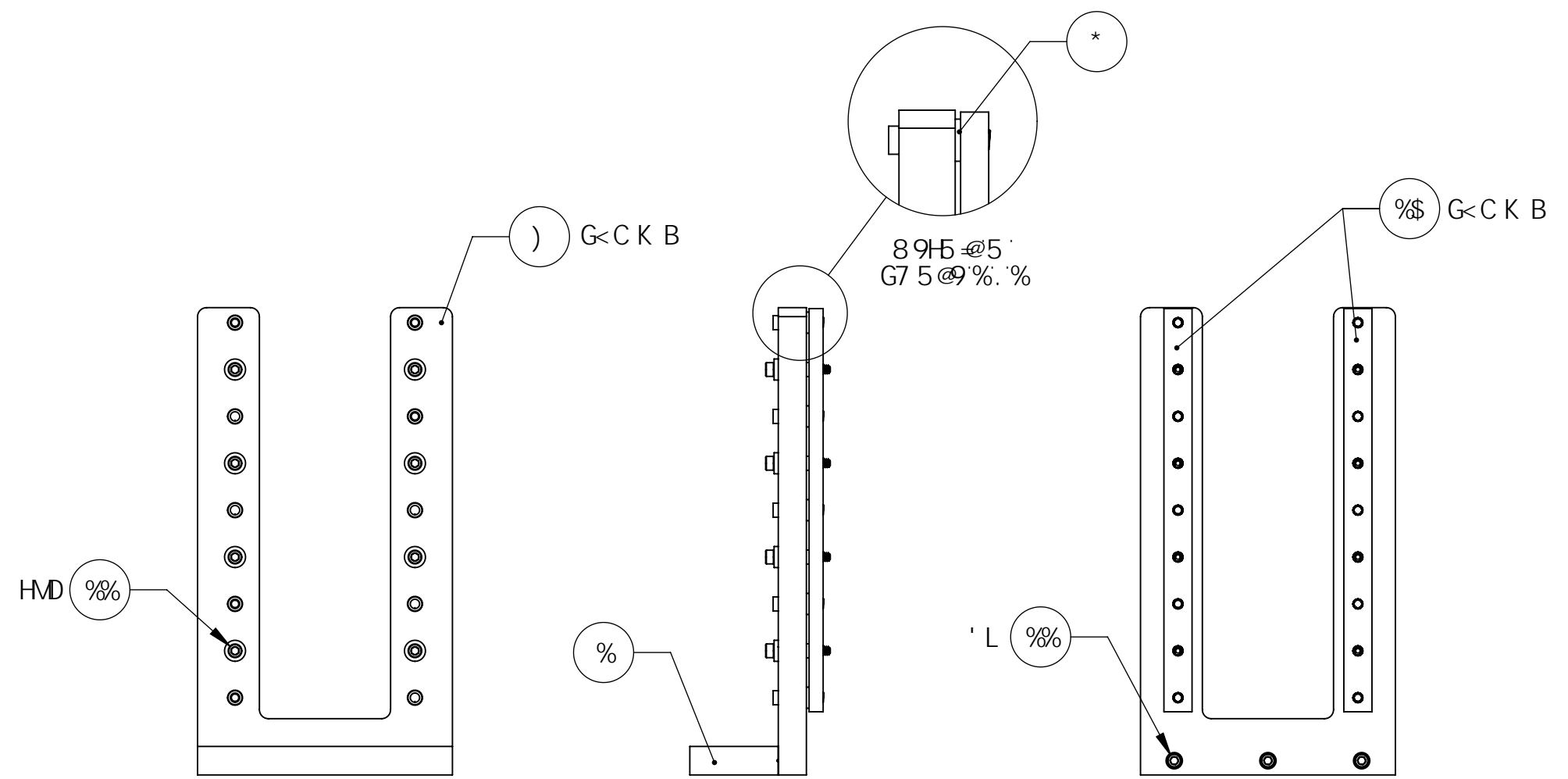
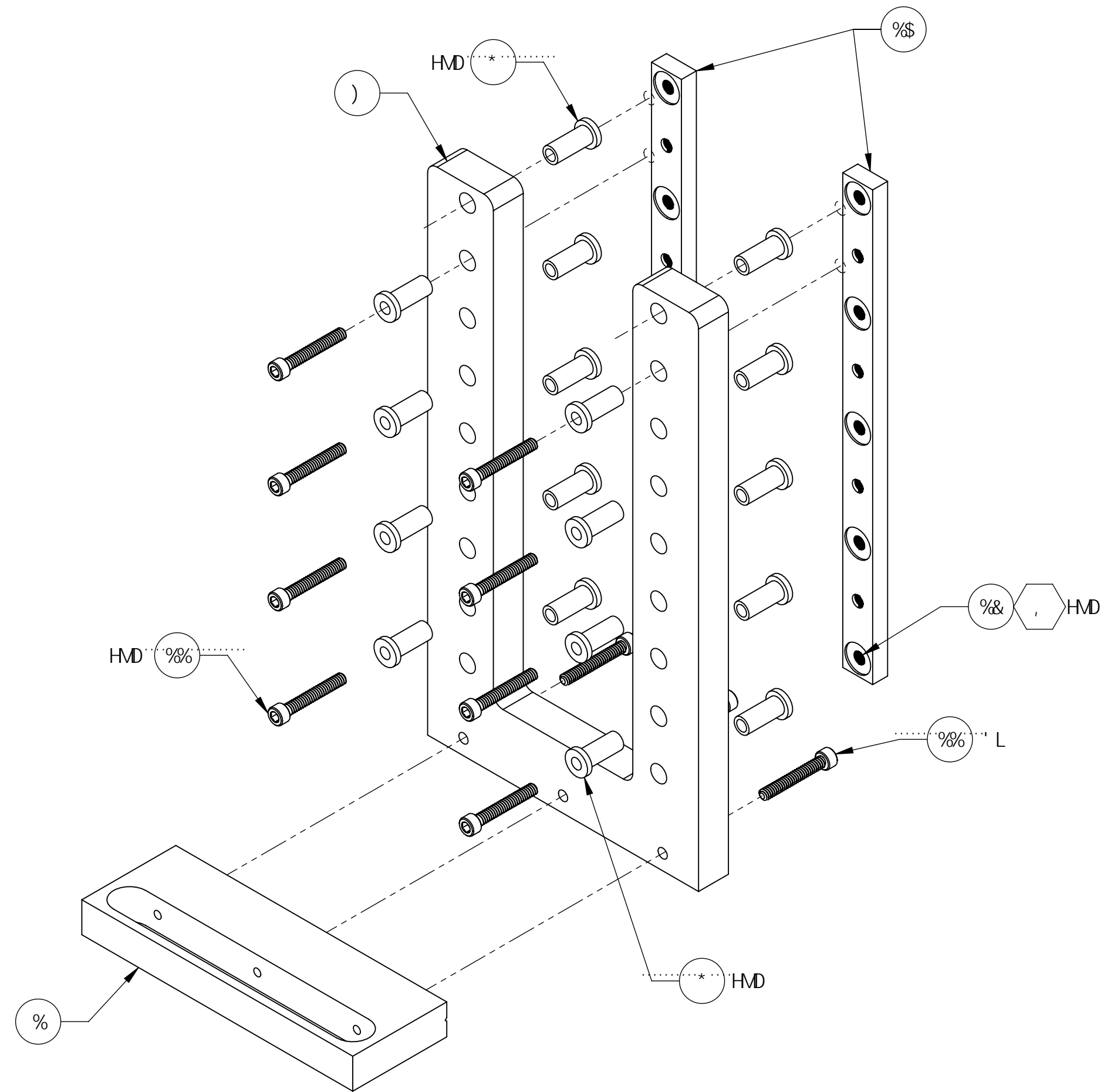

Table with 7 columns and 15 rows containing alphanumeric characters and symbols, possibly a code or data table.

Complex layout area containing text, logos (LIGO, GMG), and technical specifications. Includes labels like 'B #5', 'B #5 σjBw', and '8%\$\$%) +'. There are also some graphical symbols like a square with a circle and a square with a cross.



LIGO 75@CFB-5-BG#H H9C: H97 <BC@; M
 A 50057 <I G#HG-BG#H H9C: H97 <BC@; M

G#P 8K; "BC"	F9J"
7	8%\$\$\$ (+ j'
G7 5@. %% DFC>97 HCB.	G< 99H&C: &