

BCH9G7CBHBI 98.

G7 F 69Z 9B: F5J 9f5 J 6F5HC FMHC C@A 5M69  
I 98LZ 6G9F A 5F? CF A 97 <5B 7 5@MG5A D  
fBC #?GCF 8M9G 8F5K #; D5FHBI A 69FZ  
F9J GC B f5B8 J 5F 5BHC F "HMD9" 5DD@7 56@E  
CB BC H8 Q F: 57 9C: D5FH: C @C K 98 CB H 9  
B9LH@B9K #: 5 H F998# HIG9F 5@BI A 69F"  
G9F 5@BI A 69F G G 5FH5H\$S%: CF H 9: FGH  
5FH7 @5B8 DFC 7 998 7 C B G97 I HJ 9@M1 G9  
A B A I A "\$%&" <# <7 <5F57 H9F G2 I B @GGH 9  
GA9 C: H 9 D5FH8 7 H5H9GA 5 @9F 7 <5F57 H9F G  
9L5A D@9 8LLLLLLL!J N2HMD9 LLLZ G#B LLL

\*"5DDFCLA 5H9K 9# <H'G99: 9@8 C: 8F5K #; "  
+""A 57 <B95@G F: 57 9GHC F9A CJ 9CL 89G5B8 A @: B G<2  
.....I G9C: 5 6F5G 9F9A CJ 5@H7 <B E I 9G 6BC H5 @C K 98"  
.....F9: 9F HC @: C I9\$- \$\$' \*"  
.....5 @ D5FHG<5 @69A 5BI: 57 H F98 #B 57 7 CF85B7 9K #<  
.....@: C GD97 # 7 5HC B 9\$- \$\$' \*("

-""5 @A 5H9F 5@GHC 69J F: B A 5H9F 5@FY"BC K 9@8 F9D5 F GZ  
.....D@: GCF F97 M7 @8 A 5H9F 5@BC F9D5 FGG<5 @69A 589I B @GG  
.....5DDFCJ 98 #B 58J 5B7 9Z5B8 #B K F HB; Z6M@: C @6C F5HC FM  
.....F9: 9F HC @: C I9\$- \$\$' \*("

%\$" G F: 57 9: B G< HC 695GDFC 7 9G98: FCA A @#G DD@9FZ: F99: FCA  
.....G7 F5H7 <9GCF; C I: 9G

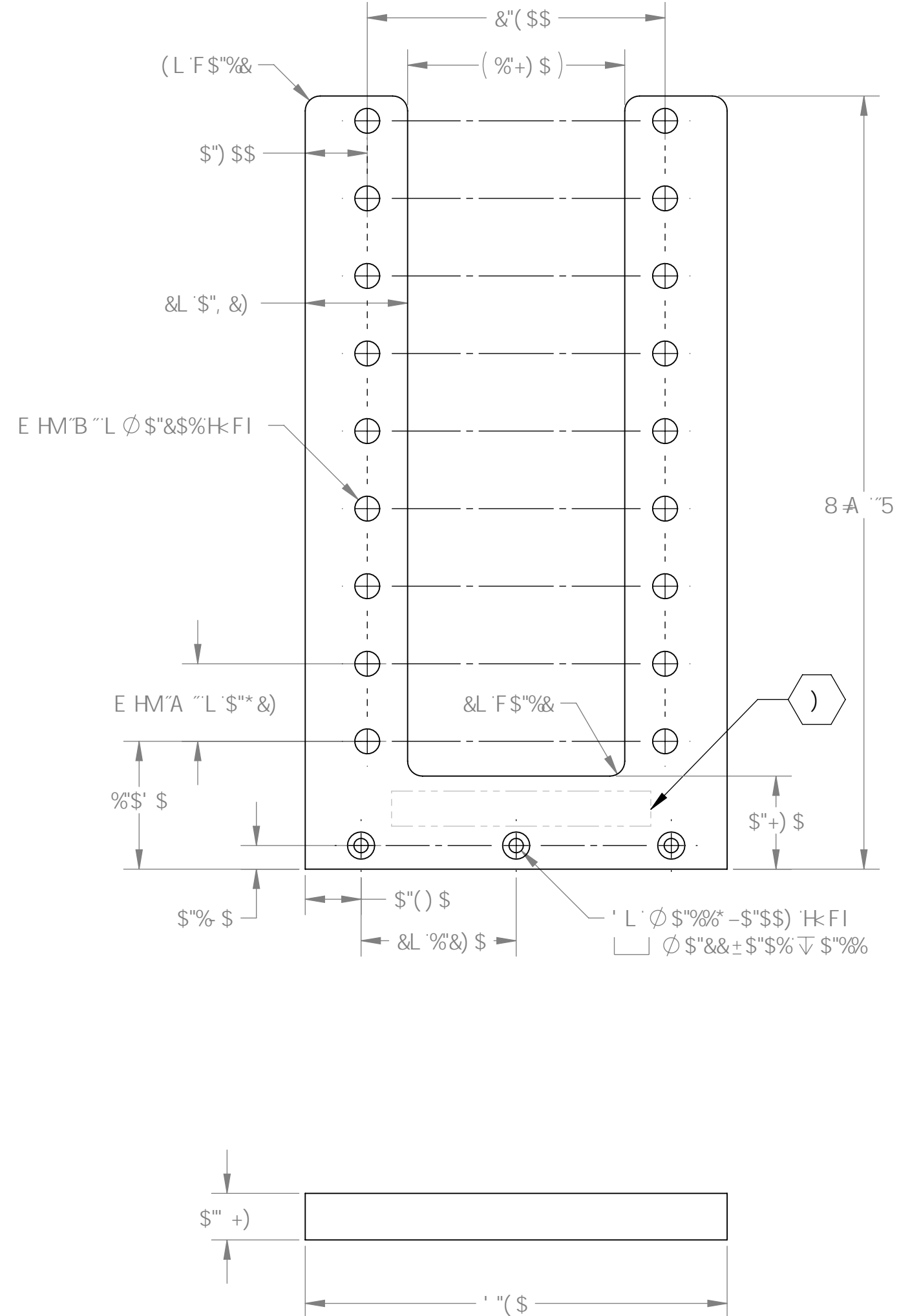

F9J "	85H9	87B	8F5K #; HF99
j %	\$( '5I ; '&\$%\$		
j &	\$- BCJ '&\$%\$		
j '	%\$: 96 '&\$%\$	9%\$\$\$- -	

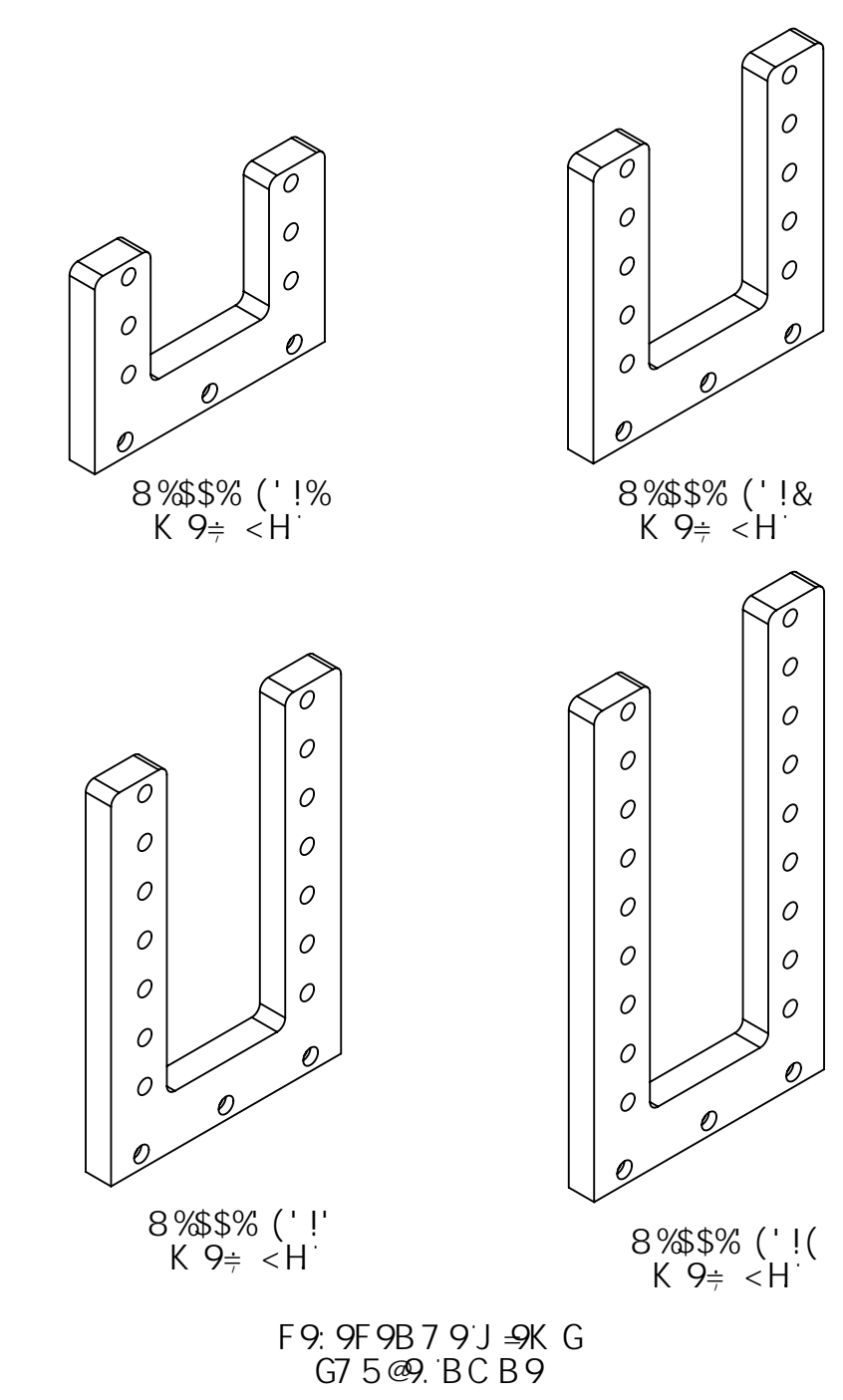

D5FHBI A 69F	8-A "5"	E HM'A "	E HM'B "
8%\$\$% (' !% K 9# <H'	&"( ,	&	*
8%\$\$% (' !& K 9# <H'	' "+'	(	%\$
8%\$\$% (' !' K 9# <H'	( "-,	*	%(\
8%\$\$% (' !( K 9# <H'	*"&	,	%

5 BCH9G5B8 HC @F5B7 9G #I B @9GCH 9FK 69GD97 # 98L

8-A 9BGC BG5F9 #B #7 <9G

HC @9F5B7 9G  
"LL" "±" "\$&  
"LLL" "±" "\$\$)

5B; I @F± "\$)" °

% B H9FDF 9H8F5K #; D9F 5GA 9M( " ) !% - (" &" F9A CJ 95 @G<5FD 98; 9Gz "\$\$) !"\$% " : C F A 57 <B 98 D5FHG FCI B8 : 5 @98: 9G5DDFCLA 5H@9MF "\$&: C F G<99HA 9H5@D5FHG " " 8C BCHG7 5@: FCA 8F5K #; " (" 5 @A 57 <B B; : @ #GA I GH69: I @MGMB H 9H7 Z: I @MK 5H9F GC @ 6@9 5B8: F99C: Q @ I FZG@7 CB9Z5B8 7 <@CFB9'

A 5H9F 5@ : B G< \*

\*\$\*%H\* '5` \*

σj bWΛ \*

8%\$\$% ( \*

LIGO 75@CFB-5-BG#H H9C: H97 <BC@; M A 5GG57 <I 9H9G-BG#H H9C: H97 <BC@; M

GVB9A 58J5B7 98 @# C G 6 GVB9A GMG

B9LH5GGM

D5FH5A 9 U@# C ž7 56@9 6F57? 9HI DF ÷ <HA C I BH

89G# B9F	>"85J G	8%A 5M&\$S	GNP 8K; "BC"	F9J "
8F5: H9F	>"85J G	&( A 5M&\$S	7	j'
7 <97? 9F	G'G: 5B7 @9	\$- BCJ '&\$%\$	8%\$\$% ('	
5DDFCJ 5@		G7 5@9 %%	DFC >97 HC B.	G<99H% C: %