

NOTES: (UNLESS OTHERWISE SPECIFIED)
 X

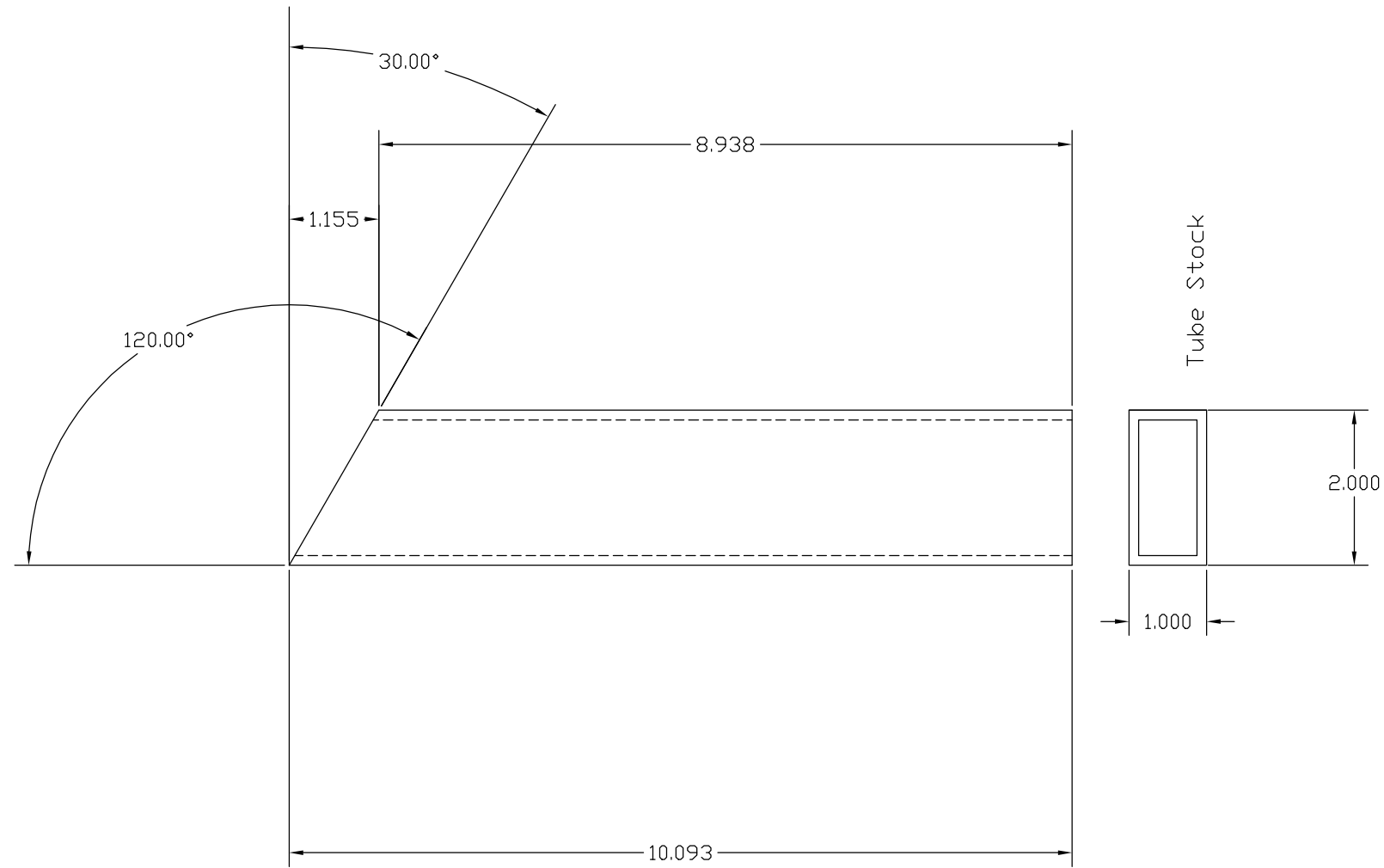

MAKE TWO PER ASSEMBLY

REF	QTY	PART or DRWG No.	DESCRIPTION	MATERIAL
5	-	-	-	-
4	-	-	-	-
3	-	-	-	-
2	-	-	-	-
1	-	-	-	-

UNLESS OTHERWISE SPECIFIED
 DIMENSIONS ARE IN INCHES

TOLERANCES:
 FRACTIONAL ± 1/32
 TWO PLACE DECIMAL ± .01
 THREE PLACE DECIMAL ± .005
 ANGULAR ± 1 deg.

ANGULAR MACH ± BEND ±
 FINISHED SURFACE RMS 63
 BREAK CORNERS and EDGES
 REMOVE ALL BURRS

MATERIAL: Alum: 6061 T6
 TUBE 1 X 2 X .12

HEAT TREAT: TBD

FINISH: None

USED ON: XXX

NEXT ASS'Y: XXX

REV	DESCRIPTION	DCN NUMBER	APPR'D	CHECK	DRWN	DATE	SCALE	SHEET
A	RELEASE	E010214-00-D			KENM	10-31-01		
00	PRE-RELEASE	-			KENM	09-25-01		

LIGO CALIFORNIA INSTITUTE OF TECHNOLOGY
 MASSACHUSETTS INSTITUTE OF TECHNOLOGY

TITLE
 BRACE #4

CAD FILE: D010212-A
 SIZE: D
 DWG. NO.: D010212-A

