

D1000862 Pin Cap, Locker, aLIGO BSC-ISI, PART PDM REV: X-009, DRAWING PDM REV: X-006

NOTES CONTINUED:
 5. SCRIBE, ENGRAVE, OR MECHANICALLY STAMP (NO INKS OR DYES) DRAWING PART NUMBER, REVISION (AND VARIANT OR "TYPE" IF APPLICABLE ON NOTED SURFACE OF PART FOLLOWED ON THE NEXT LINE WITH A THREE DIGIT SERIAL NUMBER. SERIAL NUMBERS START AT 001 FOR THE FIRST ARTICLE AND PROCEED CONSECUTIVELY. USE MINIMUM 0.12 HIGH CHARACTERS, UNLESS THE SIZE OF THE PART DICTATES SMALLER CHARACTERS. A VIBRATORY TOOL MAY BE USED.
 EXAMPLE DXXXXXX-VY, TYPE-XX, S/N XXX.
 6. APPROXIMATE WEIGHT = 0.14 LB.
 7. MACHINE ALL SURFACES TO REMOVE OXIDES AND MILL FINISH. USE OF ABRASIVE REMOVAL TECHNIQUES IS NOT ALLOWED.
 8. ALL PARTS SHALL BE MANUFACTURED IN ACCORDANCE WITH LIGO SPECIFICATION E0900364.

REV.	DATE	DCN #	DRAWING TREE #
v1	01 Mar. 2010	E1000115	E1000025
v2	20 July 2010	E1000263	E1000025

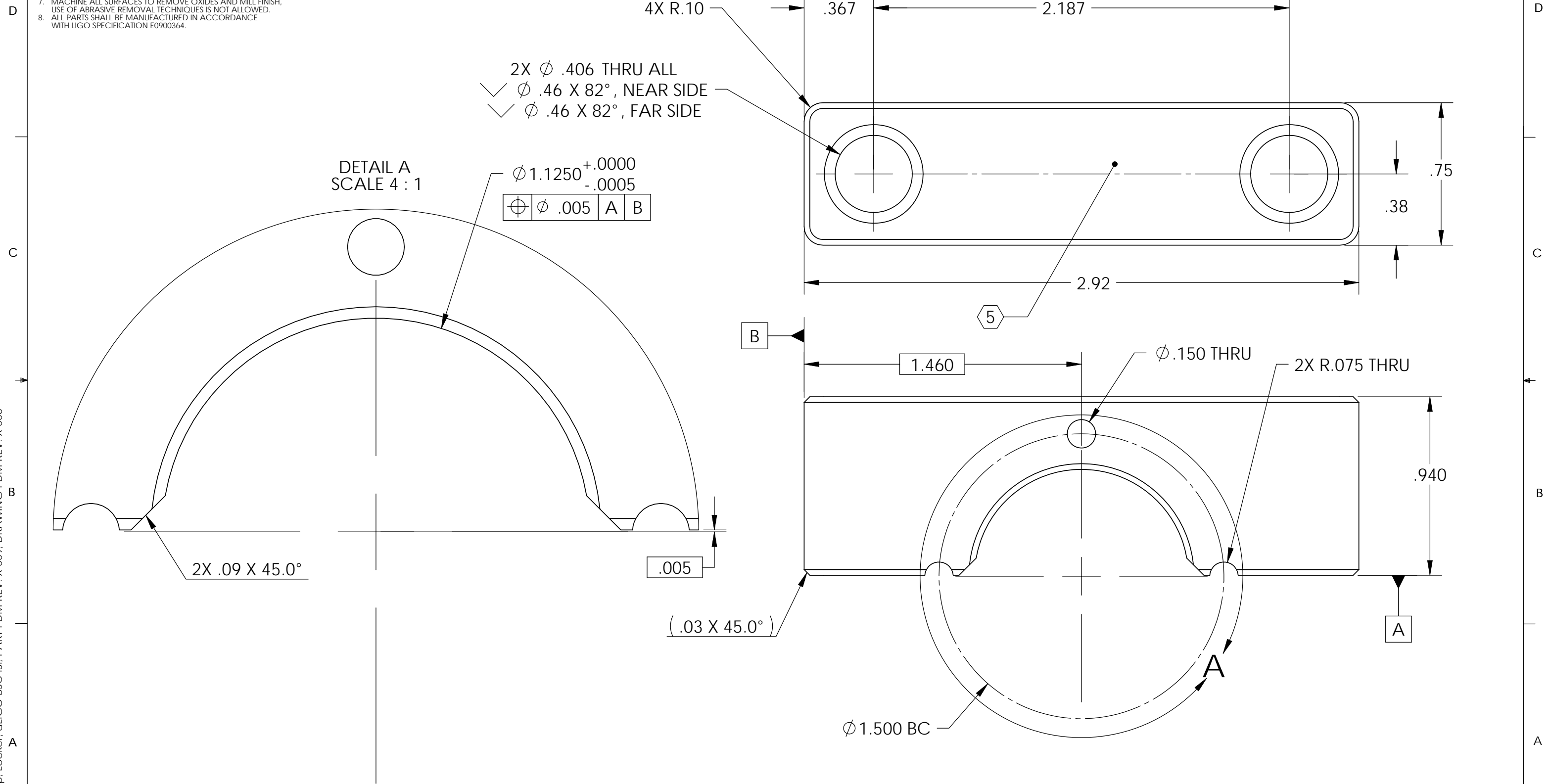

NOTES AND TOLERANCES: (UNLESS OTHERWISE SPECIFIED)				LIGO CALIFORNIA INSTITUTE OF TECHNOLOGY MASSACHUSETTS INSTITUTE OF TECHNOLOGY		PART NAME	
DIMENSIONS ARE IN INCHES TOLERANCES: .XX ± .015 .XXX ± .005 ANGULAR ± .5°				1. INTERPRET DRAWING PER ASME Y14.5-1994. 2. BREAK ALL EDGES AND CORNERS .03 X 45°.		PIN CAP, LOCKER, aLIGO BSC-ISI	
3. DO NOT SCALE FROM DRAWING. 4. ALL MACHINING FLUIDS MUST BE FULLY SYNTHETIC, FULLY WATER SOLUBLE AND FREE OF SULFUR, SILICONE, AND CHLORINE.				SYSTEM ADVANCED LIGO	SUB-SYSTEM SEI	DESIGNER A.STEIN 01 Mar. 2010	SIZE DWG. NO. B D1000862
MATERIAL 2024-T351 Al		FINISH 63 μinch		NEXT ASSY D1000854		DRAFTER M.HILLARD 01 Mar. 2010	REV. v2
						CHECKER F.MATICHARD 01 Mar. 2010	SCALE: 2:1
						APPROVAL K.MASON 01 Mar. 2010	PROJECTION:
						SHEET 1 OF 1	