

NOTES CONTINUED:
 ⑤ BAG ALL ITEMS AND MARK OR TAG EACH BAG WITH DRAWING NUMBER, REVISION, AND QUANTITY. EXAMPLE: DXXXXXX-VY, QTY: TBD

REV.	DATE	DCN #	DRAWING TREE #
v1	22 MAR 2010	E1000144	-
-	-	-	-
-	-	-	-

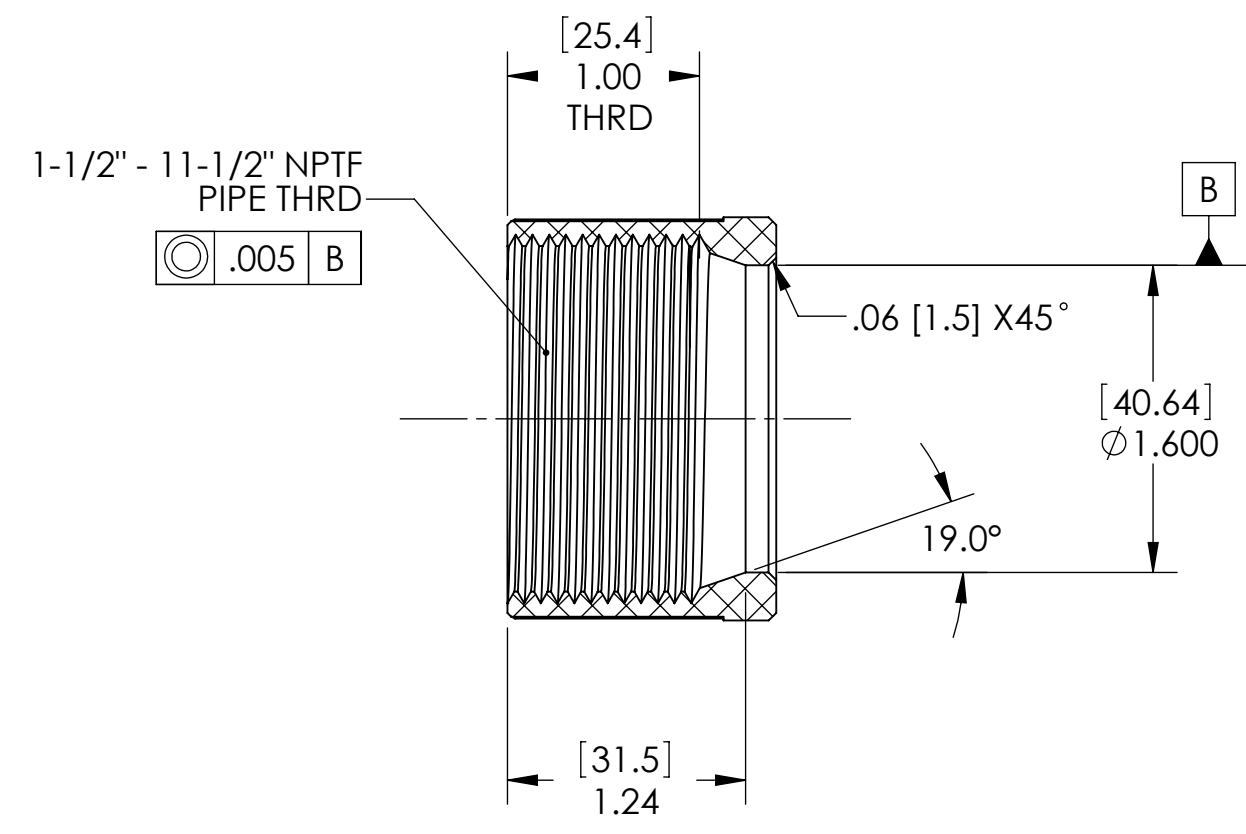

SECTION D-D
SCALE 1 : 1

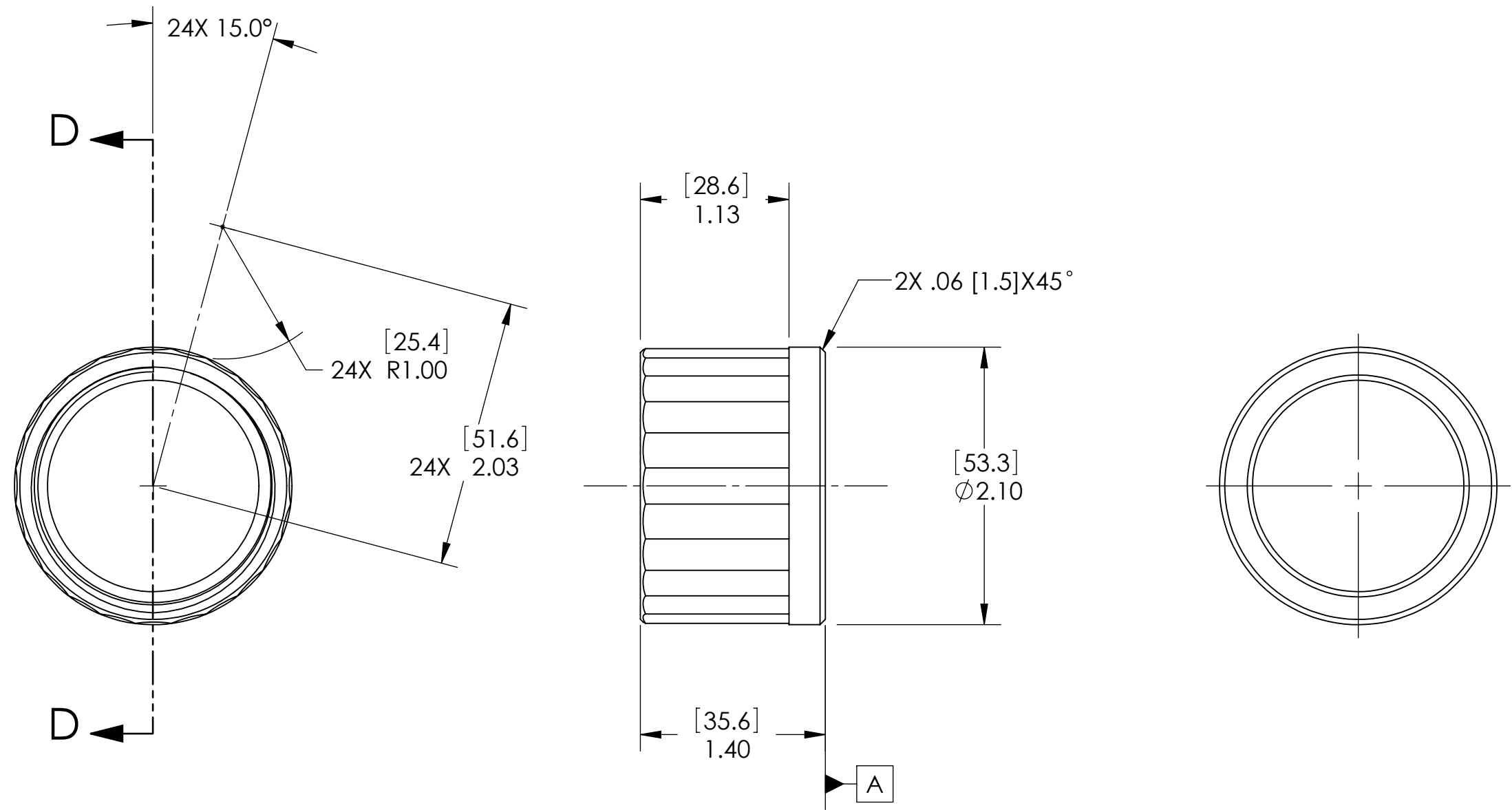
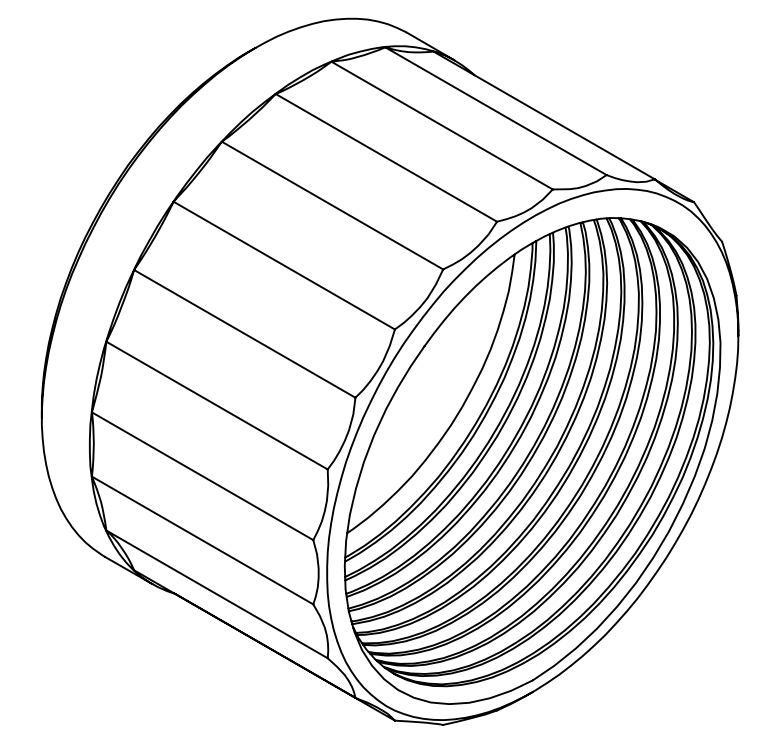

DIMENSIONS ARE IN INCHES
 TOLERANCES:
 .XX ± .01
 .XXX ± .005
 ANGULAR ± 0.5°

NOTES AND TOLERANCES: (UNLESS OTHERWISE SPECIFIED)
 1. INTERPRET DRAWING PER ASME Y14.5-1994.
 2. REMOVE ALL SHARP EDGES, R.02 MIN.
 3. DO NOT SCALE FROM DRAWING.
 4. ALL MACHINING FLUIDS MUST BE FULLY SYNTHETIC, FULLY WATER SOLUBLE AND FREE OF SULFUR, SILICONE, AND CHLORINE.
 MATERIAL: PVC Rigid
 FINISH: N/A μinch

LIGO CALIFORNIA INSTITUTE OF TECHNOLOGY
 MASSACHUSETTS INSTITUTE OF TECHNOLOGY
 SYSTEM: ADVANCED LIGO
 SUB-SYSTEM: IAS
 NEXT ASSY: D1000604

PART NAME: COUPLER CMPRSN MOUNT TS PERISCOPE
 DESIGNER: ESS 03/22/2010
 DRAFTER: ESS 03/22/2010
 CHECKER: S. SHANKLE 29 APR 2010
 APPROVAL: [Signature]
 SIZE: c DWG. NO.: D1000609
 SCALE: 2:1 PROJECTION: [Symbol]
 REV. v1 SHEET 1 OF 1