

NOTES CONTINUED:  
 5. SCRIBE, ENGRAVE, OR MECHANICALLY STAMP (NO INKS OR DYES) DRAWING PART NUMBER AND REVISION ON NOTED SURFACE FOLLOWED ON THE NEXT LINE BY A THREE DIGIT SERIAL NUMBER. SERIAL NUMBERS START AT 001 FOR THE FIRST ARTICLE AND PROCEED CONSECUTIVELY. USE .07" HIGH CHARACTERS. EXAMPLE: DXXXXX-VY, S/N 001. VIBRATORY TOOL MAY BE USED. A

6. APPROXIMATE WEIGHT = X.XXX LB.

7. MACHINE ALL SURFACES TO REMOVE OXIDES AND MILL FINISH. USE OF ABRASIVE REMOVAL TECHNIQUES IS NOT ALLOWED. REFER TO LIGO-E0900364

8. ALL PARTS SHALL BE MANUFACTURED IN ACCORDANCE WITH LIGO SPECIFICATION E0900364.

9. ALL HELI-COIL HOLES TO BE PREPARED ACCORDING TO EMHART HELI-COIL PRODUCT CATALOG, HC2000, REV 4

NOTES 13 and 14 DO NOT APPLY TO THIS PART

10. ALL HELI-COIL INSERTS TO BE INSTALLED BY LIGO PERSONNEL. AFTER DELIVERY OF FINISHED PARTS, USE NITRONIC 60 THREADED INSERTS.

11. ALL MATERIAL IS TO BE VIRGIN MATERIAL (i.e. NO WELD REPAIRS, PLUGS OR RECYCLED MATERIAL). NO REPAIRS SHALL BE MADE UNLESS APPROVED IN ADVANCE, AND IN WRITING, BY LIGO LABORATORY. REFER TO LIGO-E0900364.

12. SURFACE FINISH TO BE AS-PROCESSED FROM MILL/SUPPLIER, FREE FROM SCRATCHES OR GOUGES.

13. PART WILL BE PORCELAIN COATED PER LIGO SPECIFICATION E0900083 AFTER FABRICATION. THE INDICATED HOLES WILL BE MASKED PRIOR TO PORCELAIN COATING TO APPROXIMATELY .25" HOLE DIAMETER CENTERED ON BOTH SIDES OF THE HOLE.

14. DIMENSIONS APPLY BEFORE PORCELAIN COATING UNLESS SPECIFIED.

15. BEND RADIUS: UNLESS OTHERWISE NOTED, THE BEND RADIUS SHOULD BE THE MINIMUM REQUIRED TO FORM WITHOUT CRACKING OR REQUIRING ADDITIONAL WORK WHEN FORMING. IN PARTICULAR IF SHEET METAL IS TO BE PORCELAIN COATED, THE BEND RADIUS SHALL BE A MINIMUM OF .12" OUTSIDE RADIUS OF BEND UNLESS OTHERWISE NOTED.

REV.	DATE	DCN #	DRAWING TREE #

**CONNECTOR J1**

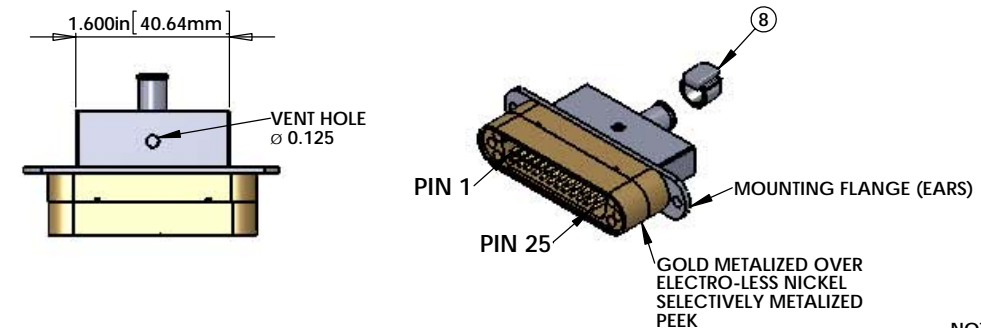

**CONNECTOR J2**

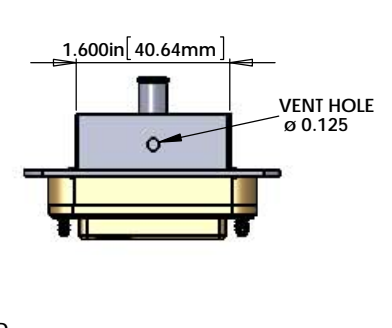

**CONNECTOR J1**

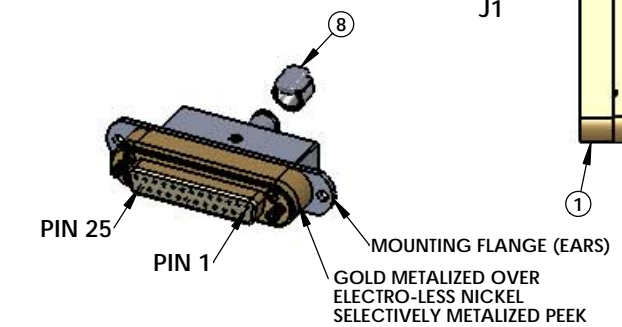

**CONNECTOR J2**

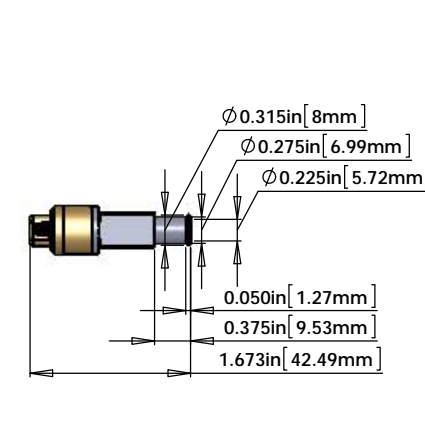
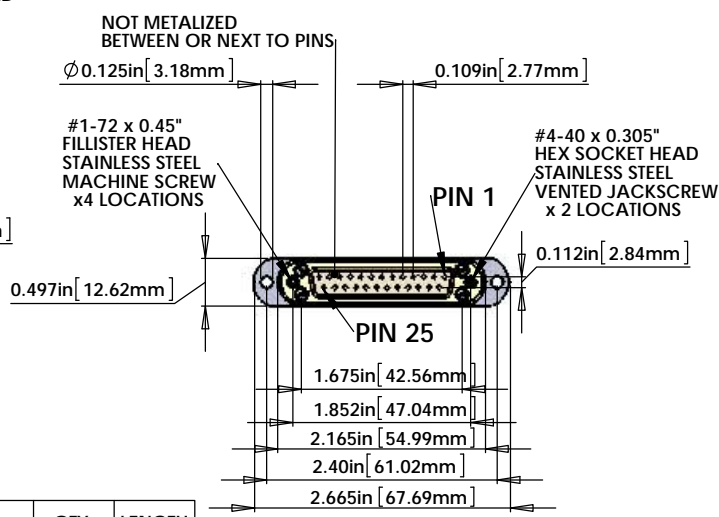
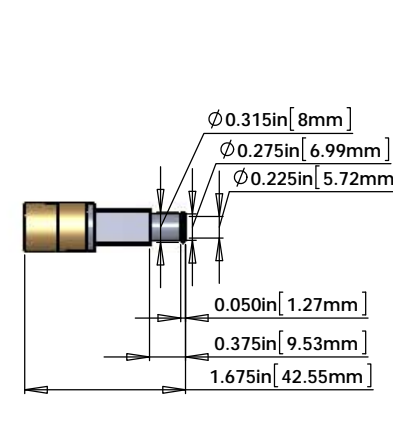
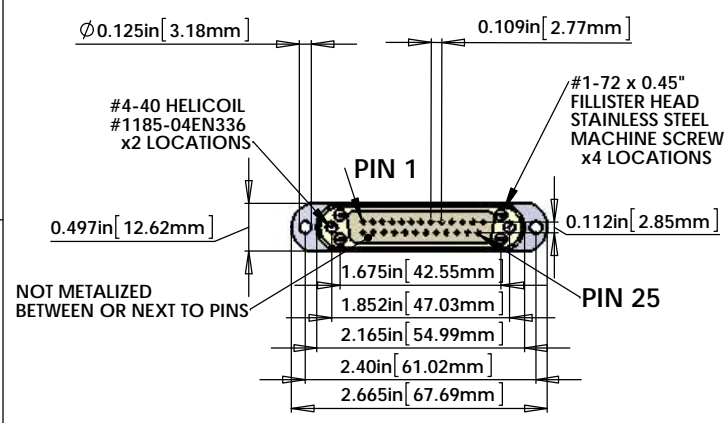
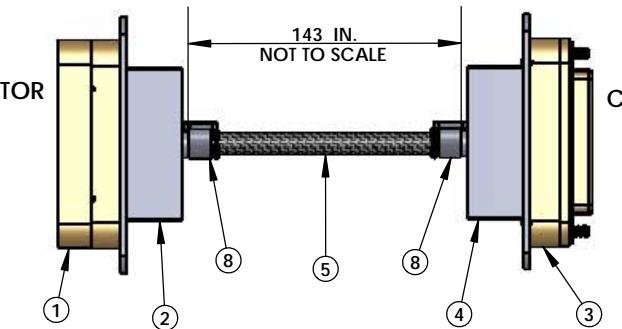

V25J-143 CABLE ASSEMBLY CIRCUIT SUMMARY					
V-DB25 M/S1-143-DB25 F/S1					
CABLE NAME	COND. - WIRE ID	TWISTED PAIR	LENGTH *	FROM	TO
V25J-143	13 COND. CABLE	(6 TOTAL)	143 in.	Conn. J1	Conn. J2
	W1	SHIELD	143 in	PIN 1, SHELL	PIN 1, SHELL
	W8	TP-1	143 in	PIN 8	PIN 8
	W20		143 in	PIN 20	PIN 20
	W9	TP-2	143 in	PIN 9	PIN 9
	W21		143 in	PIN 21	PIN 21
	W10	TP-3	143 in	PIN 10	PIN 10
	W22		143 in	PIN 22	PIN 22
	W11	TP-4	143 in	PIN 11	PIN 11
	W23		143 in	PIN 23	PIN 23
	W12	TP-5	143 in	PIN 12	PIN 12
	W24		143 in	PIN 24	PIN 24
	W13	TP-6	143 in	PIN 13	PIN 13
	W25		143 in	PIN 25	PIN 25

PIN 14,2,15,3,16,4,17,5,18,6,19,7 N/C (NOT CONNECTED)

\* THE LENGTH SHOWN IN THIS LIST IS THE LENGTH OF THE CABLE BETWEEN THE TWO CONNECTORS. ADD ADDITIONAL LENGTH AS NECESSARY FOR THE INTERNAL WIRING OF THE CONNECTORS AND STRIP LENGTH.

ITEM NO.	PART NUMBER	DESCRIPTION	QTY.	LENGTH
1	TICOR # (TS0149-25CG20BS1-225F) OR EQUIVALENT **	DB25 MALE CONNECTOR (J1) FOR UHV (GOLD METALIZED PEEK)	1	
2	TICOR # (TS0148-25CG20BS1-225F) OR EQUIVALENT **	DB25 CONNECTOR BACKSHELL (WITH EARS) FOR UHV (STAINLESS STEEL) WITH Ø0.225" I.D. PORT	1	
3	TICOR # (TS0148-25CG20BS1-225F) OR EQUIVALENT **	DB25 FEMALE CONNECTOR (J2) FOR UHV (GOLD METALIZED PEEK)	1	
4	TICOR # (TS0148-25CG20BS1-225F) OR EQUIVALENT **	DB25 CONNECTOR BACKSHELL (WITH EARS) FOR UHV (STAINLESS STEEL) WITH Ø0.225" I.D. PORT	1	
5	COONER WIRE # CZ1105 + 6 + 7	13 COND. (6 TW PAIR + 1 WIRE + SHIELD) CABLE WITH 6 COPPER BRAID (SHIELD) AND 7 PEEK OVERBRAID	1	143in *
6	CONTINENTAL PART #24x3x40BC	COPPER BRAID - CONTINENTAL CORDAGE PART #24x3x40BC	1	
7	#6759	PEEK BRAID - PART #6759 MANUFACTURED WITH ZEUS 0.016" BLACK PEEK DRAWN MONOFILAMENT	1	
8	GLENAIR # 600-052 or BAND-IT # A10086	GLENAIR # 600-052 STANDARD BRAID CLAMP or BAND-IT PART # A10086 (0.240" WIDE) ("BAG OF 100" # A10089)	2	

\* NOTE: USE WHATEVER LENGTH IS NECESSARY FOR THE INTERNAL WIRING OF THE CONNECTORS AND STRIP LENGTH TO ACHIEVE THE CORRECT OVERALL LENGTHS.

\*\* NOTE: SEE THE "TICOR CONNECTOR PART NUMBER BUILDER" DCC#D1000219 FOR DETAILS ON THIS PART NUMBER.

NOTES: ( UNLESS OTHERWISE SPECIFIED )

A. MATERIAL: a. J1 CONNECTOR SHELL - GOLD OVER ELECTRO-LESS NICKEL SELECTIVELY METALIZED PEEK VICTREX 450GL30. b. J2 CONNECTOR SHELL - GOLD OVER ELECTRO-LESS NICKEL SELECTIVELY METALIZED PEEK VICTREX 450GL30. c. BACKSHELLS - STAINLESS STEEL WITH VENT HOLE. d. CONTACTS - BERYLLIUM COPPER ALLOY C17300, 0.000050 MIN. GOLD OVER NICKEL. e. HARDWARE: STAINLESS STEEL, PASSIVATED. f. PEEK BRAID - PEEK VICTREX GRADE TDS-450CA30 CARBON LOADED - SUPPLIED BY LIGO.

B. CABLE 13 COND. 28 AWG (65/46), WITH PFA INSULATION COONER WIRE #CZ1105. 6 TWISTED PAIRS ( 4 TO 5 TWISTS PER INCH ) + 1 WIRE. OVERALL 40AWG COPPER BRAID 50% COVERAGE - SUPPLIED BY LIGO. OVERALL PEEK BRAID MIN. 50% COVERAGE. OVERALL CABLE O.D. WILL BE ~ 0.240 IN.

C. CONNECTORS WILL BE SUPPLIED WITH HARDWARE. THE SCREWS SHOULD BE THE PROPER LENGTH FOR MATING.

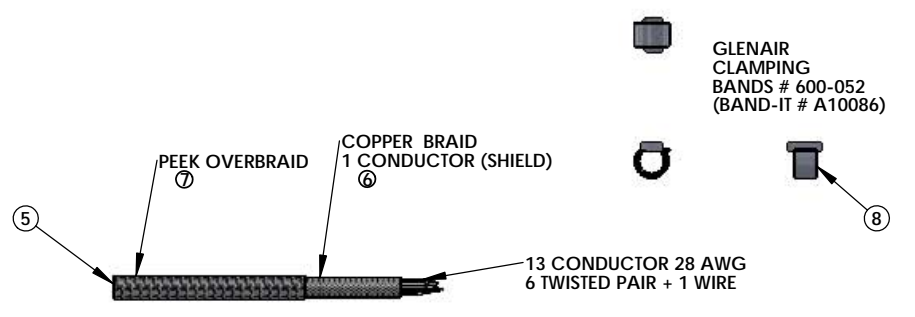

ISC TRANSMON QPD CABLE		
SEISMIC TABLE TO SUSPENDED TRANSMON TABLE		
V-DB25 M/S1-143-DB25 F/S1		
STANDARD USE FOR THIS CABLE		
SUBSYSTEM	AIR/VAC	STANDARD USE
ISC	IN-VAC	TRANSMON TABLE TO SEISMIC TABLE QPD FOR TRANSMON

DIMENSIONS ARE IN		TOLERANCES:		ANGULAR ± °	
XX ±	XXX ±	XX ±	XXX ±	XX ±	XXX ±
Material <not specified>		FINISH		μinch	

NOTES AND TOLERANCES: (UNLESS OTHERWISE SPECIFIED)		LIGO CALIFORNIA INSTITUTE OF TECHNOLOGY MASSACHUSETTS INSTITUTE OF TECHNOLOGY		PART NAME	
1. INTERPRET DRAWING PER ASME Y14.5-1994.	2. REMOVE ALL SHARP EDGES, .005-.015, FOR MACHINED PARTS. ROUND ALL EDGES APPROXIMATELY R.02 FOR SHEET METAL PARTS.	SYSTEM	SUB-SYSTEM	DESIGNER	R. ABBOTT
3. DO NOT SCALE FROM DRAWING.	4. ALL MACHINING FLUIDS MUST BE FULLY SYNTHETIC, FULLY WATER SOLUBLE AND FREE OF SULFUR, SILICONE, AND CHLORINE.	ISC	ISC	DRAFTER	E. BROWN
		NEXT ASSY		CHECKER	
				APPROVAL	

DATE	SIZE	DWG. NO.	REV.
JUL/02/2012	D	D1000568	v8

SCALE: 1:1 PROJECTION: SHEET 1 OF 1

D:\000568\46\cable\V25J-143\_P1.PDM REV. DRAWING (PDR) REV. 8.000