



LIGO Laboratory / LIGO Scientific Collaboration

LIGO- E1000040-v2

aLIGO

June 10, 2010

---

TRANSMISSION MONITOR TELESCOPE SUSPENSION  
(TMS)  
PRELIMINARY DESIGN

---

K .Mailand, Jay Heefner, Sam Waldman, Mike Smith, Matt Evans

Distribution of this document:  
LIGO Science Collaboration

This is an internal working note  
of the LIGO Project.

**California Institute of Technology**  
LIGO Project – MS 18-34  
1200 E. California Blvd.  
Pasadena, CA 91125  
Phone (626) 395-2129  
Fax (626) 304-9834  
E-mail: info@ligo.caltech.edu

**Massachusetts Institute of  
Technology**  
LIGO Project – NW22-295  
185 Albany St  
Cambridge, MA 02139  
Phone (617) 253-4824  
Fax (617) 253-7014  
E-mail: info@ligo.mit.edu

**LIGO Hanford Observatory**  
P.O. Box 1970  
Mail Stop S9-02  
Richland WA 99352  
Phone 509-372-8106  
Fax 509-372-8137

**LIGO Livingston Observatory**  
P.O. Box 940  
Livingston, LA 70754  
Phone 225-686-3100  
Fax 225-686-7189

**Table of Contents**

1	INTRODUCTION	7
1.1	Scope	7
1.2	PURPOSE	7
1.3	Group task assignment	8
1.4	LIGO Documents	9
1.5	Acronyms	10
2	TMS DESIGN DESCRIPTION AND SUMMARY OF REQUIREMENTS	11
2.1	Requirements document (T0900265-v1)	11
2.2	TMS Suspension	11
2.3	Optics Table (Optics Platform)	14
2.4	Telescope, (BRT) Beam Reducing telescope	15
3	TMS DESIGN APPROACH	17
3.1	Suspension	17
3.2	Optics Table (Optical platform)	19
3.3	Telescope (BRT) Beam Reducing telescope	23
3.4	Off-axis Parabolic Mirrors, Manufacturing Tolerance	25
4	TMS TELESCOPE ALIGNMENT PROCEDURE	26
4.1	Secondary Mirror Translation and Tilt Correction	26
4.2	Autocollimator and Shack-Hartmann Instruments	26
4.3	Beam Splitter	27
4.4	Coarse Alignment with Autocollimator	28
4.4.1	Initial Misalignment Conditions	29
4.4.2	Telescope Mounting to Table	29
4.4.3	Total number of Assemblies	29
5	TMS OPTICAL LAYOUT	31
5.1	ZEMAX Optical layout Plan view	31
5.2	ZEMAX Layout elevation VIew	32
6	TELESCOPE ALIGNMENT PROCEDURE	33
6.1	ZEMAX Model	33
6.1.1	Shack Hartmann wavefront sensor	33
6.1.2	Wavefront Aberration	34

6.1.3 Ellipticity and Wavefront Aberration	34
7 TMS CONSTRUCTION	35
7.1 Materials	35
7.2 Processes	35
7.3 Cleaning	35
7.4 Component Naming	35
7.5 Interchangeability	35
8 TMS CHAMBER LOCATIONS (LHO / LLO)	36
8.1 H1 & H2 at Hanford, L1 at IIVINGSTON	36
9 TMS PERFORMANCE CHARACTERISTICS	41
9.1 Transfer Functions and Input Noise	42
10 TMS FAULT DETECTION, ISOLATION AND RECOVERY	45
10.1 Earth Quake Stops	45
10.2 Method of implementing	45
10.3 Software watch dogs	46
11 INTERFACE CONTROL	47
11.1 The TMS Telescope Assembly	47
11.2 The TMS Telescope Assembly Service Fixture	47
11.3 The fixture Attachment and repositioning of TMS	47
11.4 Electronic cables and connectors	48
12 RELEVANT RODA CHANGES AND ACTIONS COMPLETED	49
13 INSTALLATION AND INTEGRATION PLAN	50
14 FIRST ARTICLE ASSEMBLY AT CIT	51
14.1 The telescope and suspension	51
14.2 pre assembly and alignment at the site	51
14.3 loading the tms onto the cartridge	51
14.4 Final Alignment / tool setups	53
15 ESTIMATE OF TIME AND PERSONNEL TO COMPLETE TMS ASSEMBLY	54
15.1 Equipment	54
15.2 Personnel	54
15.2.1 Time est.	54
15.2.2 Cartridge Assembly of the TMS	54

15.2.1 Tms alignment to etm in bsc	54
16 LONG LEAD PROCUREMENTS	55
16.1 Telescope	55
16.1.1 Primary mirror	55
16.1.2 Secondary mirror	55
16.1.3 Suspension	55
16.2 Optical Table	55
16.2.1 Optical Table components	55
17 TECHNICAL, COST AND SCHEDULE RISKS AND PLANNED MITIGATION	56
17.1 PER RISK REGISTRY M080359-V5	56
16.2 Problems and Concerns	56
16.2.1 Suspension Concerns	56
17.1.2 Optical Table Concerns	56
18 TEST PLAN OVERVIEW	57
18.1 Suspension Seismic Test at cit	57
18.2 Lab Equipment and setup	57
18.3 Identification of testing resources	58
18.4 Telescope Optical System	58
18.5 Planned tests to verify performance	58
19 ENVIRONMENT, SAFETY, AND HEALTH ISSUES	61
19.1 personnel and equipment safety hazards	61
20 QUALITY ASSURANCE PROVISIONS	62
20.1 General	62
20.2 Responsibility for Tests	62
20.3 Configuration Management	62
20.4 Quality conformance	62
20.5 Inspections	62
21 GENERAL SYSTEM CONSIDERATIONS	63
21.1 Environmental Conditions	63
21.2 Electromagnetic Radiation	63
21.3 Transportability	63
21.4 Finishes	63

21.5 Safety	63
22 TECHNICAL MANUALS AND PROCEDURES	64
22.1 Procedures	64
22.2 Manuals	64
22.3 Documentation Numbering	64
22.4 Test Plans and Procedures	64
22.5 Logistics	64
22.6 Precedence	64
22.7 Qualification	64
23 PREPARATION FOR DELIVERY	65
23.1 Preparation	65
23.2 Packaging	65
23.3 Marking	65
24 NOTES	67
25 TMS TEAM	69

## **TABLE OF FIGURES**

<i>Fig. 1: Transmission Monitor Suspension (TMS) / ETM shown at Left.....</i>	<i>9</i>
<i>Fig. 2: Suspension Structure w/ 4 Safety wires shown .....</i>	<i>11</i>
<i>Figure 3: Optics Platform table top.....</i>	<i>14</i>
<i>Figure 4: BEAM REDUCING TELESCOPE w/ Optics and Baffle .....</i>	<i>15</i>
<i>Figure 5: TMS Suspension Structure.....</i>	<i>18</i>
<i>Figure 6: The D060403 Top Mass w/ added mass to equal 40kg.....</i>	<i>19</i>
<i>Figure 7: Annotated TMS table optics schematic top view.....</i>	<i>20</i>
<i>Figure 8: Optical Table ISC Side Shown.....</i>	<i>21</i>
<i>Figure 9: Optical Table - (Bottom View).....</i>	<i>21</i>
<i>Figure 10: Suspension Wire Clamp (4) Attach. to Telescope / Optical Table ..</i>	<i>22</i>
<i>Figure 11: Telescope Structure with Optics, and front Baffle .....</i>	<i>23</i>
<i>Figure 12: Secondary Mirror Mount .....</i>	<i>24</i>
<i>Figure 13: ZEMAX model of off-axis parabolic telescope.....</i>	<i>24</i>
<i>Figure 14: Double Pass Alignment Beam.....</i>	<i>27</i>
<i>Figure 15: Alignment Beam Splitter .....</i>	<i>27</i>
<i>Fig 16: Shack-Hartmann sensor / Auto Collimator Flange Mt.....</i>	<i>28</i>
<i>Figure 17: Naming Conventions.....</i>	<i>30</i>
<i>Figure 18: Plan View Layout of the TMS Optical Table and the Input and Output TMS and Beam .....</i>	<i>31</i>
<i>Figure 19: TMS Telescope Beams.....</i>	<i>32</i>
<i>Figure 20: Wavefront Map from Shack-Hartmann Sensor .....</i>	<i>33</i>

Figure 21: Wavefront Aberrations after Alignment Using Five Degrees of Freedom of Secondary Mirror .....34

Figure 22: BSC-5-H2 (HANFORD ONLY) .....36

Figure 23: BSC-6 H2 (HANFORD ONLY) .....37

Figure 24: BSC-9-H1 & L1 (Hanford and Livingston) .....38

Figure 25: BSC-9-H1 & L1 (End View Primary mirror side).....38

Figure 26: BSC10-H1 & L1 (Hanford and Livingston ) .....39

Figure 27: TMS Suspension with ETM @ Left a minimum of 4.5" clearance between TMS Telescope Frame and ETM frame .....40

Figure 28: Parameters Drawing D0902773 v4 showing suspension wire and TMS telescope and optical table cg locations.....41

Figure 29: Estimated displacement and angular noise spectra for the TMS. The target (dashed grey line) refers only to the pitch and yaw (ty and tz) degrees of freedom. The resonances are left un-damped in this model to facilitate identification of their frequencies, though damping will be present in the actual system. ....42

Figure 30: TMS Ground to Displacement Transfer Functions (no damping). These transfer functions are of little interest to the noise performance, but should be helpful in characterizing the suspension, and in constructing control and damping loops. ....43

Figure 31: TMS Ground to Angle Transfer Functions (no damping). Note that the dominant transfer to ty is from y rather than ty, so this transfer function is shown instead.....43

Figure 32: Displacement noise from the BSC ISI used as input to the model. 44

Figure 33: Earthquake Restraint Typ. ....45

Figure 34: The service tooling will allow the telescope and optical table to be moved away from the ETM for accessibility. ....47

Figure 35: Tooling to fix the TMS telescope to the Suspension frame .....52

Figure 36: TMS Telescope with Optical Table .....59

Figure 37: TMS ISC Optical Table.....60

# 1 INTRODUCTION

The purpose of this document is to present the Preliminary Design of the TRANSMISSION MONITOR SUSPENSION (TMS)

## 1.1 SCOPE

This Document will show, System Requirements, Design Approach, Assembly Procedures and the Location of System Interfaces with the BSC chambers. The Transmission Monitor Suspension ( TMS ) Meets applicable aLIGO Design and Material specifications. This document references alignment and installation procedures.

## 1.2 PURPOSE

- Collects 1064 nm light transmitting through ETM and provides it for Interferometer Sensing and Control
- Mode matches 532 nm light for Arm Length Stabilization
- Provides input for intermittent Hartmann monitoring system
- Transmits any residual 1064 nm radiation to a beam dump

The **TRANSMISSION MONITOR SUSPENSION** (TMS) is an in-vacuum component that is located behind the ETM (End Test Mass) and is mounted to the BSC ISI platform. The TMS Telescope is a reference for beam location and receives the laser beam transmitted through the ETM. This beam can be used for interferometer sensing and control. (FIG 1) The TMS is also used in the opposite direction, for injection of the green laser beam used in the Arm Length Stabilization (ALS) scheme. Finally, the TMS also accommodates probe beams for the Hartmann sensor that monitors the curvature of the ETM.

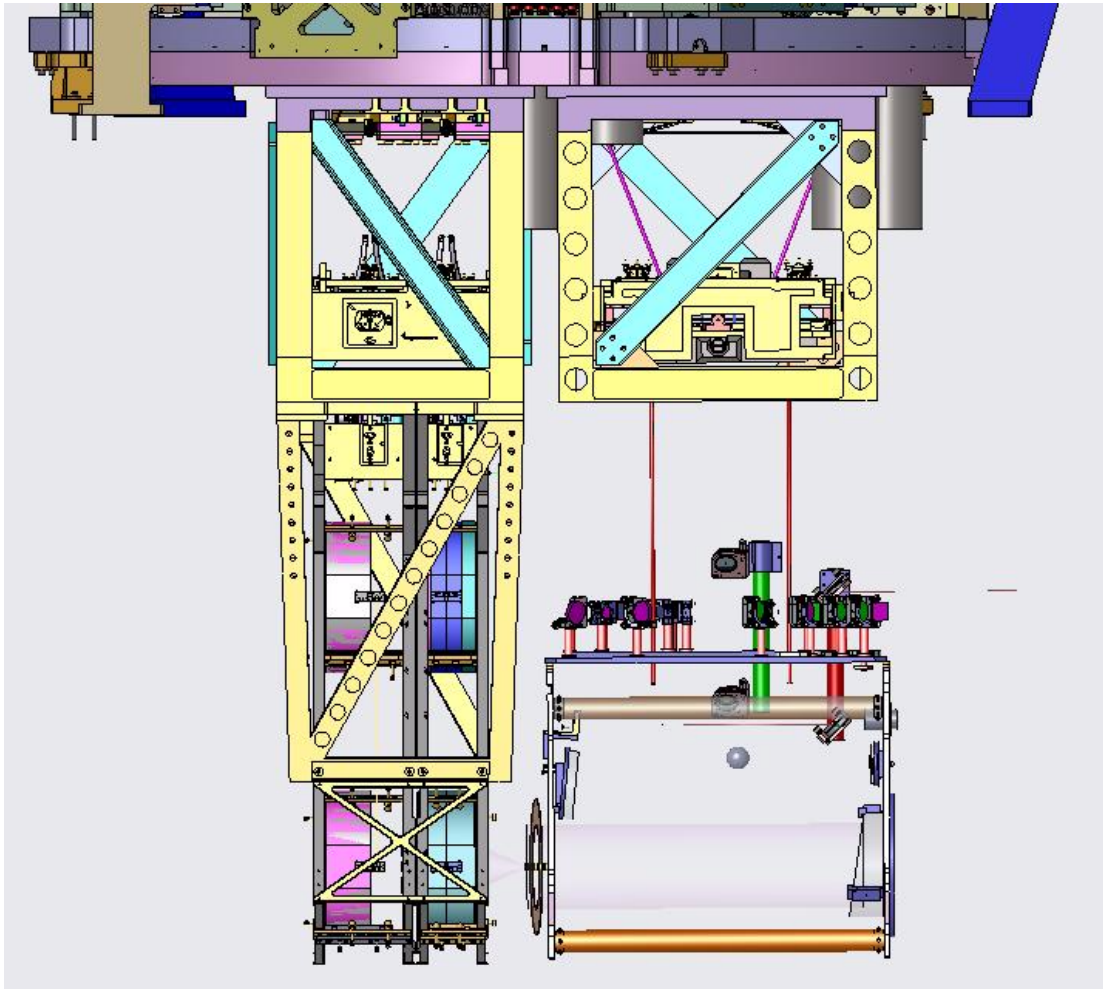
The TMS assembly consists of an optics platform, a suspension for that platform, a beam reducing telescope, and various opto-mechanical and opto-electronic components for beam detection and control. The assembly is split between AOS and ISC, as follows:

### 1.3 GROUP TASK ASSIGNMENT

- Optics platform (Table): AOS
  
- Suspension: AOS
  
- Beam reducing telescope: AOS
  
- Injection and retrieval of primary and reference Hartmann beams
  - AOS
- Post-telescope optics and electronics for 1064 nm beam detection:
  - ISC
- Pre-telescope optics and electronics for ALS 532 nm beam injection:
  - ISC

This document contains the Design Description for the AOS scope of the TRANSMISSION MONITOR SUSPENSION (TMS) .





**Fig. 1:** Transmission Monitor Suspension (TMS) / ETM shown at Left

## 1.4 LIGO DOCUMENTS

TMS Requirements	<a href="#">(T0900265-v1)</a>
Secondary Mirror Specification	E0900349-v4
Primary Mirror Specification	E0900347-v4
ETM Transmon design	G0900459-v2
Preliminary calculations for TMS table sensitivity	G0900293-v3
Zemax Optical Layout	D0900446-v11
Suspension Pitch and Yaw ranges	T1000268-v1
UHV cleaning and qualification procedures	E960022-v7
Materials	E960050-B

Welding	E0900048-v6
Drawing requirements	E030350-v2
Transmon SUS Telescope Alignment Procedure	T1000275-v1
The Advanced LIGO ETM transmission monitor	T0900385-v04
TMS Suspension, Characterization and Tests at CIT	T1000236-v1
ETM TransMon Telescope_SUS Installation Plan	E1000097-v1
Comparasion of Telescope Optical Designs	T0900453-v2
Osem Count	E1000042-v1
aLIGO TMS Hazards Analysis	T1000311-v1

### 1.5 ACRONYMS

BSC	Beam Splitter Chamber
ETM	End Test Mass
AOS	Auxiliary Optics System (sub system)
ISC	Interferometer sensing and control
BRT	Beam Reducing Telescope
MTBF	Mean Time Between Failures
ALS	Arm Length Stabilization (green beam)
RODA	Record of decision agreement
TMS	Transmission Monitor Suspension
ISI	Interferometer Seismic Isolation
ALS	Arm Length Stabilization

## 2 TMS DESIGN DESCRIPTION AND SUMMARY OF REQUIREMENTS

The Major sub assemblies:

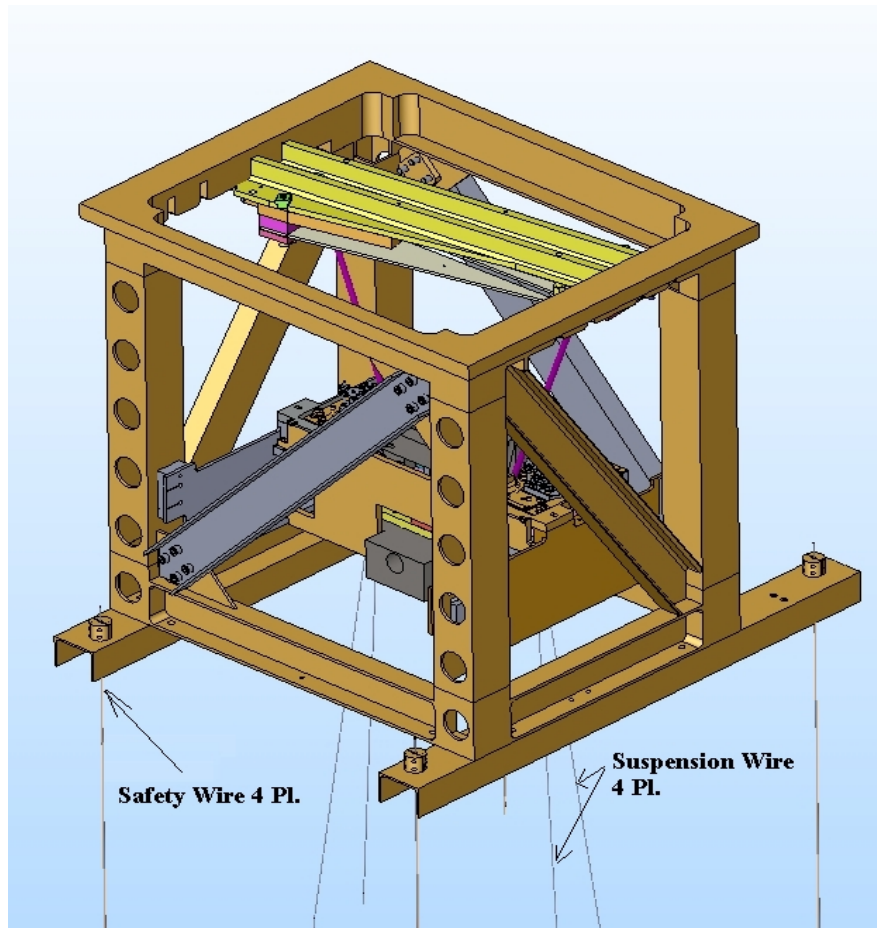
- a. Suspension
- b. Optical table W/ ISC Components
- c. Telescope

### 2.1 REQUIREMENTS DOCUMENT [\(T0900265-V1\)](#)

The fundamental TMS requirements are given in T0900265-v1.

These requirements are summarized below and additional derived requirements are given.

### 2.2 TMS SUSPENSION



**Fig. 2:** Suspension Structure w/ 4 Safety wires shown

## Suspension and Noise

6 DOF of platform are isolated

Suspension eigen-frequencies above 0.5 Hz

All rigid body modes damped to  $Q < 10$

Above 10 Hz isolation factor  $> 1000$  all 6 DOF

Displacement noise  $< \sim 3 \text{ pm} / \sqrt{(\text{Hz})}$

Angular noise  $< \sim 3f \text{ rad} / \sqrt{(\text{Hz})}$

Internal modes of suspension support 150 Hz or higher

At 3 Hz isolation factor  $> 10$  all DOF

The TMS platform must be suspended from the BSC ISI platform (rather than rigidly attached) for several reasons. First, because of the large distance between the ISI platform and the beam line, a rigid structure would have unacceptable mechanical modes (too low in frequency). Second, some additional vibration isolated is desired in order to mitigate scattered light noise due to any light scattered from the TMS optics back into the arm cavity. Finally, ISC plans on putting two alignment sensors (quadrant photo-detectors) on each TMS, so that all eight alignment degrees-of-freedom (four in each plane) of the arm cavities can be sensed by the TMS. To keep these alignment sensor signals from being spoiled by motion of the TMS itself, additional isolation beyond the ISI is needed.

The following generic requirements apply to the TMS suspension:

- All six degrees-of-freedom of the platform are to be isolated
- Suspension Eigen frequencies should be kept above 0.5 Hz, and preferably above 0.6 Hz (if possible); this is to limit excitation of the modes, since the ISI motion increases steeply below 0.6 Hz
- All rigid-body modes should be damped, to  $Q_s$  of  $\sim 10$  or lower
- Internal modes of the suspension support structure should be as high as possible and damped if possible; goal for lowest eigenmode: 150 Hz or higher

Isolation-- The isolation needed from the suspension is determined by the sensitivity of the ISC alignment sensors on the TMS platform. The modeling from which the following isolation requirements are derived is shown in G0900293-v3 (slide 5):

- Above 10 Hz: isolation factor of at least 1000, nominally in all six degrees-of-freedom.

(see below)

- Factor of 10 isolation by 3 Hz (all DOF)
- Below 1 Hz: best effort at minimizing mode amplification and long-term stability; mode amplification would be best confined to the 1-1.5 Hz band, if possible

Note that according to G0900293, isolation from ISI motion is really only needed for the angular DOF, but we are specifying the isolation to apply in all DOF because typically a suspension does not give angular isolation without the displacement isolation as well. However, if a suspension design is found that provides the above isolation for the pitch and yaw DOF of the TMS platform, but not for the other DOF, it may be acceptable.

Noise-- From G0900293-v3, the acceptable level of TMS platform noise above 10 Hz is a few pico-meters/Hz<sup>1/2</sup> in displacement, and a few femto-radians/Hz<sup>1/2</sup> in angle (the actual level shown in the plot on slide 5 is more conservative than it needs to be, by a factor of ~2-3). The isolation requirements above are consistent with this, and these noise targets can be used to evaluate other platform noise sources.

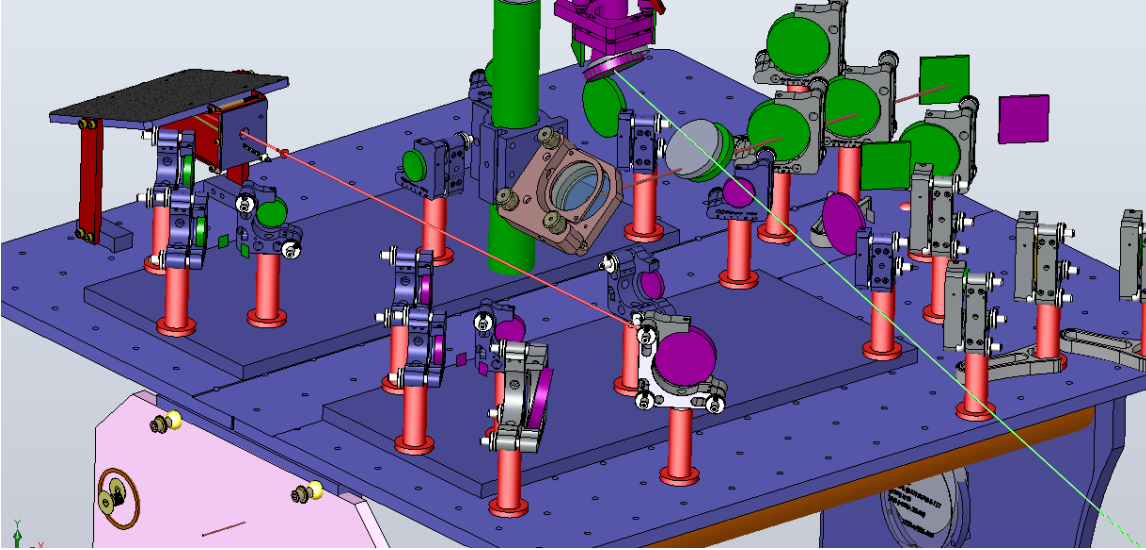
Remote position control-- Remote control of the TMS platform is not required in principal for ISC functionality. The ISC beam lines will include remotely adjustable tip-tilt mirrors to center beams on the alignment sensors. However, the trajectory of the beam delivered to the ISC beam lines by the TMS telescope must be close enough to the design value that it is within range of the ISC tip-tilt mirrors and well-within other optical apertures. This may require remote control of some degrees-of-freedom, depending on the initial alignment tolerances and estimated drift of the suspension. A suggested criterion is: let the reduced 1064 nm beam propagate an additional 1 m past the point where it enters the ISC side of the TMS table; at that point, given estimates of alignment errors and uncorrected drifts, the beam should be no more than a couple of mm away from its nominal transverse position, and no more than a mrad off its nominal propagation angle.

The position of the suspended TMS platform within the BSC chamber is a controlled interface between AOS and ISC.

## ELECTRICAL CABLING

The TMS suspension must allow for electrical cabling to be run from the ISC side of the TMS platform up to the ISI platform. This includes providing appropriate clamping points for cabling within the suspension (cabling is provided by ISC).

## 2.3 OPTICS TABLE (OPTICS PLATFORM)



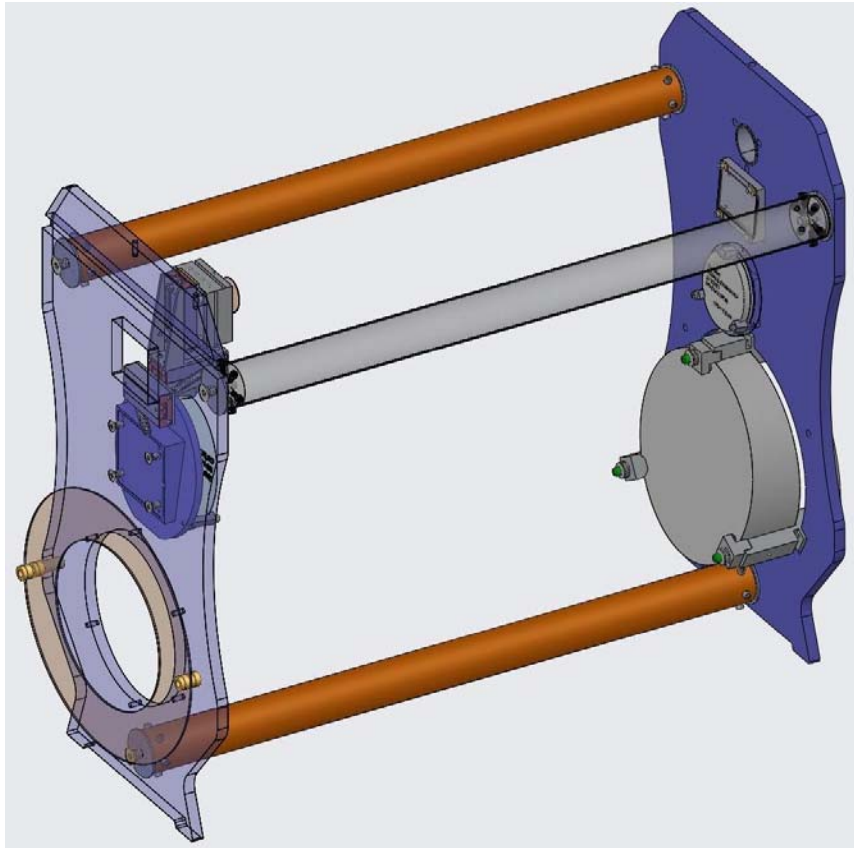
**Figure 3:** Optics Platform table top

The optics platform supports both the AOS beam reducing telescope and the ISC components. Discussions between AOS and ISC have led to the following design requirements for the platform:

- One side of the platform will be used to mount the beam reducing telescope, and the other side will be used for ISC components. Beams are directed from one side to the other through a hole in the platform.
- The nominal size of the platform working surface is 70 cm x 85 cm. It can be made larger by AOS if possible (but not smaller). The ISC side of the platform should be supplied with a matrix of tapped holes: 1/4-20 on 1 inch centers, vented.
- The platform working surfaces are to be oriented horizontally, with the beam reducing telescope to be mounted on the bottom side of the platform and the ISC components on the top side.
- Other interfaces with ISC-- although their values are not specified in this document, there are some additional interfaces that must be established between AOS and ISC:
  - location of the beam delivered to the ISC side of the platform
  - stay-clear areas on the ISC side of the platform (for suspension)



## 2.4 TELESCOPE, (BRT) BEAM REDUCING TELESCOPE



**Figure 4:** BEAM REDUCING TELESCOPE w/ Optics and Baffle

Three Telescope Design Configurations were considered.

Comparison of Telescope Optical Designs *see* **T0900453-v2**

The Final Telescope Configuration, was optimized with the Zemax Optical Design Program

Telescope General Specification:

Off Axis parabolic system 230mm dia primary w/2000 mm fl. 20x reduction.

190 mm ca, the 1064 nm main beam will be reduced to fit 2 inch ISC optics

Alignment sensors with 90 degree Gouy phases within  $\pm 10$  deg.

Handle 1064nm, 532 nm and 635nm Hartmann sensor wavelength

The telescope delivers a beam with well-known beam parameters and these beam parameters must be stable over time, with 'well-known' and 'stable' clarified in the next paragraph.

As discussed in G0900459-v2, the ISC side of the TMS employs two alignment sensors that by design are separated in Gouy phase by 90 deg. The adjustment and stability of the BRT must be such that this Gouy phase difference does not deviate by more than 10 deg from this design value. The setup and stability of the BRT must also be such that the beam size on the alignment sensors is not more than 10% different than the design value.

Within the above constraints many BRT designs are possible. The current design, as found in D0900622-v1, appears to be adequate: it reduces the beam radius from 62 mm to 3.1 mm over a distance of about 3 m (output beam is at a waist).

For expansion of the ALS green beam, the BRT design should produce an expanded green beam whose beam parameters are stable and within 10% of their design values given the design tolerances. The BRT properties are not required to be the same for the 532 nm beam and the 1064 nm beam (i.e., allowing for refractive lenses, if desired).

Additionally, the BRT must allow for convenient separation of the Hartmann sensor reference beam on the ISC side of the platform.



### 3 TMS DESIGN APPROACH

The TMS system has three major sub assemblies plus an active controls system. (Fig. 1)

The Major sub assemblies:

- a. Suspension
- b. Optical table W/ ISC Components
- c. Telescope

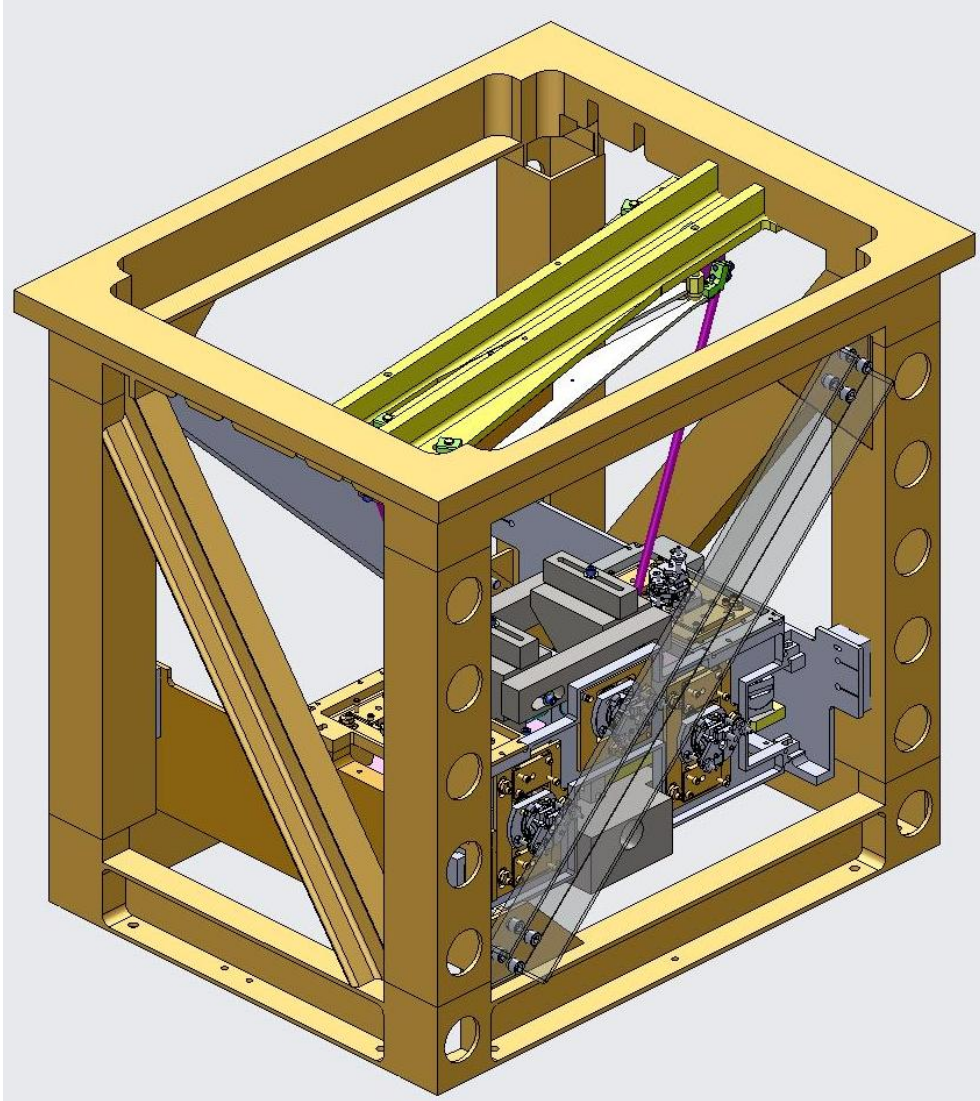
#### 3.1 SUSPENSION

The TMS platform will be suspended from the BSC ISI platform (rather than rigidly attached) for several reasons. First, because of the large distance between the ISI platform and the beam line, a rigid structure would have unacceptable mechanical modes (too low in frequency). Second, some additional vibration isolated is desired in order to mitigate scattered light noise due to any light scattered from the TMS optics back into the arm cavity. Finally, ISC plans on putting two alignment sensors (quadrant photo-detectors) on each TMS, so that all eight alignment degrees-of-freedom (four in each plane ) of the arm cavities can be sensed by the TMS. To keep these alignment sensor signals from being spoiled by motion of the TMS itself, additional isolation beyond the ISI is needed.

The suspension and control system is similar to the Quad suspension control system. Many of the control system components are identical to the Quad system and the supported masses are similar. Utilizing a major portion of the existing Quad upper suspension and components is the preferred approach to simplify the TMS- suspension development and procurement task.

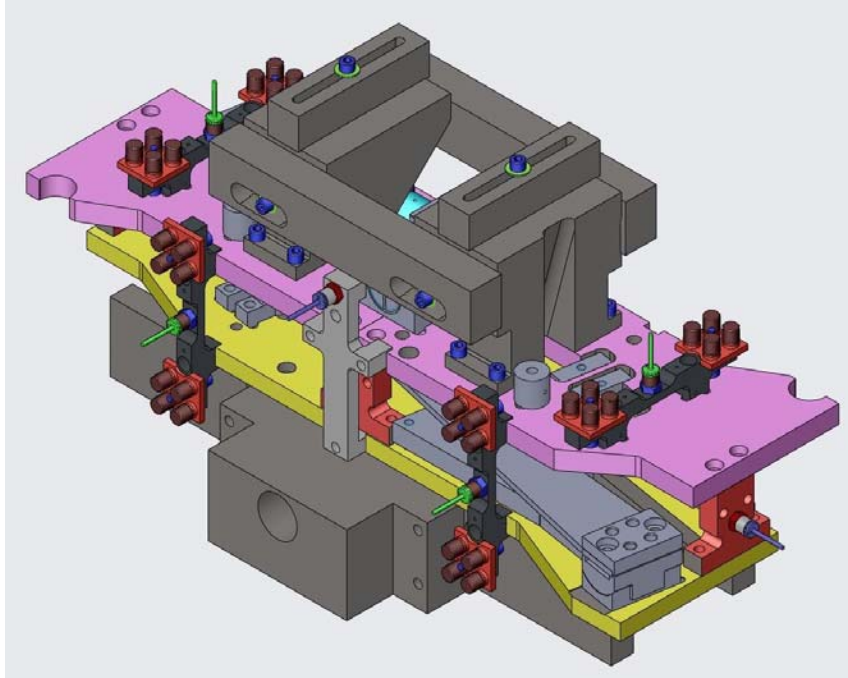
By using already proven sub-assemblies and components of the quad suspension we will save time / cost and risk.

A dynamic model of the above arrangement with the components described below predicts the control and stability of the TMS system. (Figure 29-32)



**Figure 5:** TMS Suspension Structure

**Fig.5** , Shown is the existing upper quad structure design, with existing top structure springs and the D060403 Top Mass. This assembly is modified with upper intermediate mass springs installed in the D060403 top mass, these springs were designed to carry 80kg. The telescope and TMS Optical table combined total Mass is identical at 80kg.



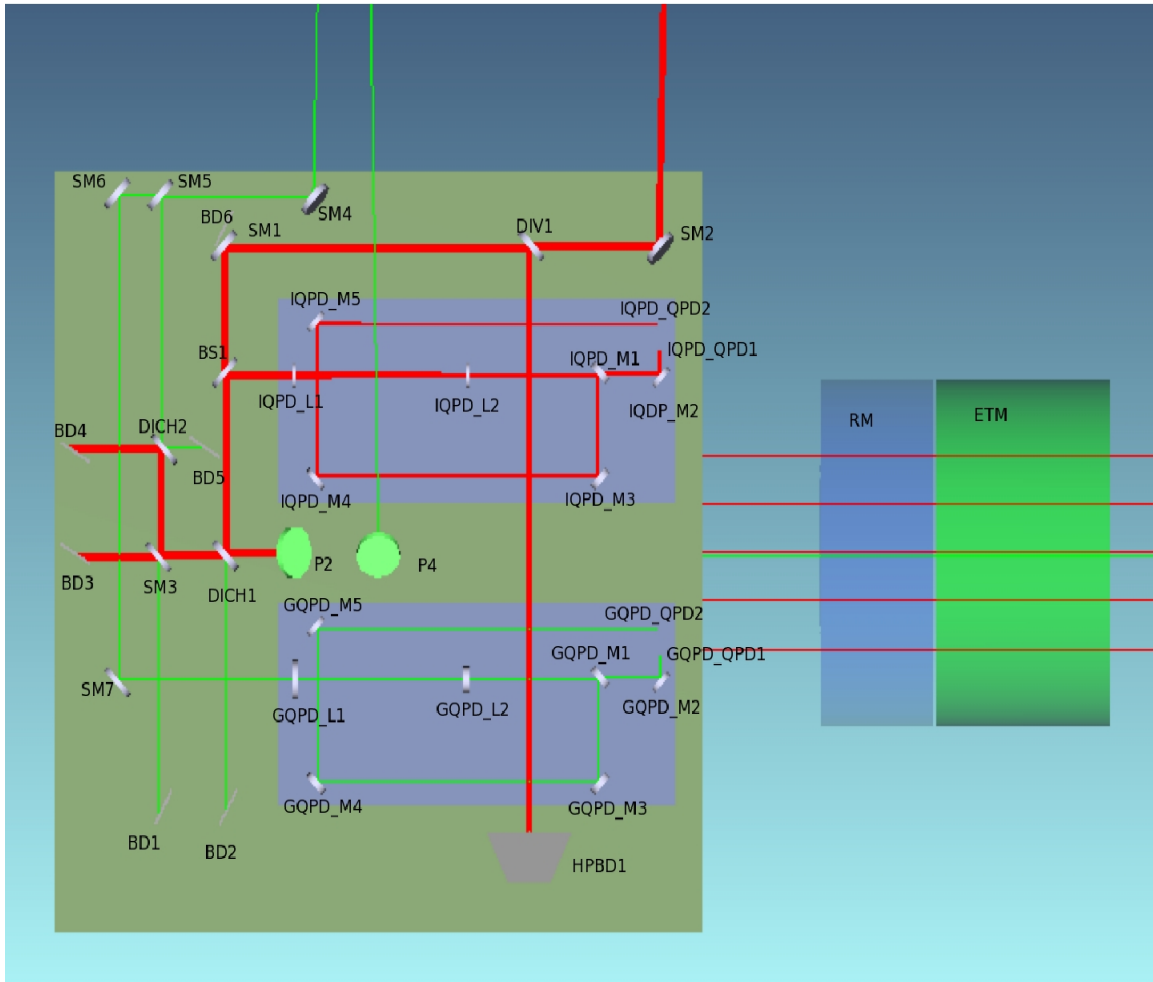
**Figure 6:** The D060403 Top Mass w/ added mass to equal 40kg

### 3.2 OPTICS TABLE (OPTICAL PLATFORM)

Ref. The Advanced LIGO ETM transmission monitor T0900385-v04

Here we describe the TMS optical layout. The TMS assembly is an in-vacuum optics table suspended immediately behind the End Test Mass (ETM) of each interferometer arm. The TMS incorporates a telescope for reducing the large diameter arm cavity beam to a manageable size, beam steering optics, and in-vacuum QPDs. During science mode, all infrared beams transmitted through the ETM are dumped on the TMS table. During lock acquisition, the TMS relays the interferometer beam to an in-air optics table with sensors indicating the beam position. Finally, the TMS table provides the input optics and alignment reference for the green beams of the Lock Acquisition Interferometer (LAI) and the Hartmann wavefront sensor.

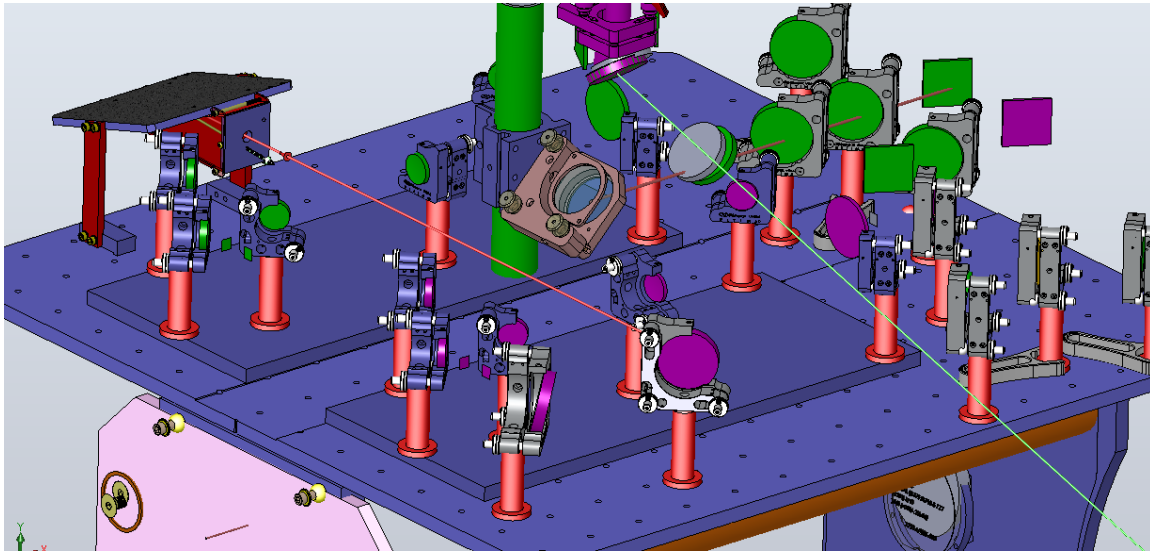
In the following sections, we describe the overall layout of the TMS table, calculate the beam reducing telescope parameters, calculate the sensitivity of the QPDs with an ideal telescope, evaluate the effects of astigmatism, determine the layout tolerances, and describe alignment procedures for each of the subsystems. We conclude with a parts list for the optical table.



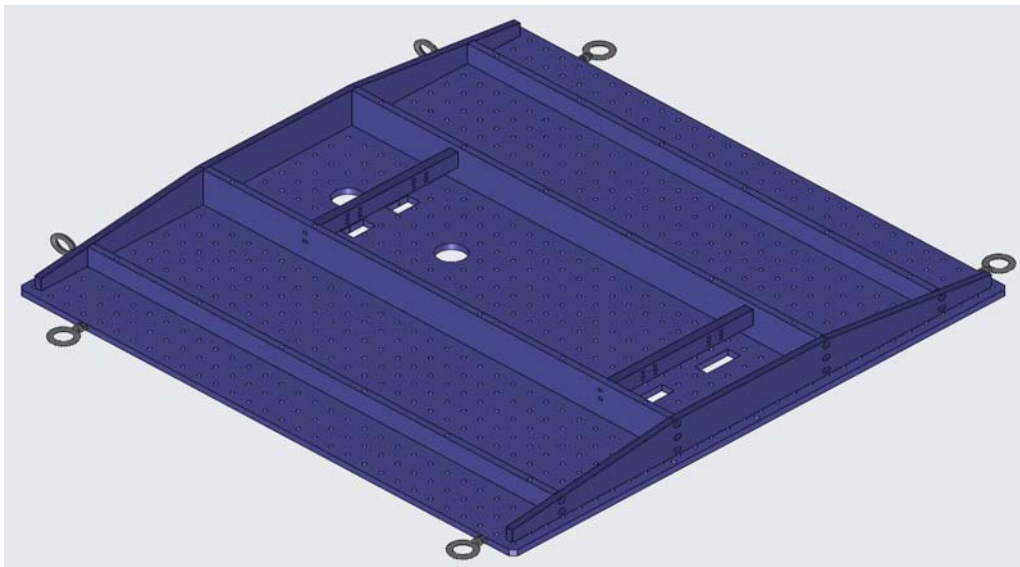
**Figure 7:** Annotated TMS table optics schematic top view.

The TMS table is designed as a single plate with the folded beam reducing telescope mounted below the table and the ISC optics mounted above. The layout is shown in ( Figure 7). The red beam traces the infrared beam from the arm cavity, through the ETM and reaction mass (here labeled "RM"), and into the telescope.

The optics platform supports both the AOS beam reducing telescope and the ISC components, Discussions between AOS and ISC have led to the following design requirements for the platform. 30" x 30' x .5' aluminum. 1/4"-20 thru tap holes on 1" centers, beam holes, and mounting provision for telescope and a stiffener frame on the table bottom side, total mass is 80kg

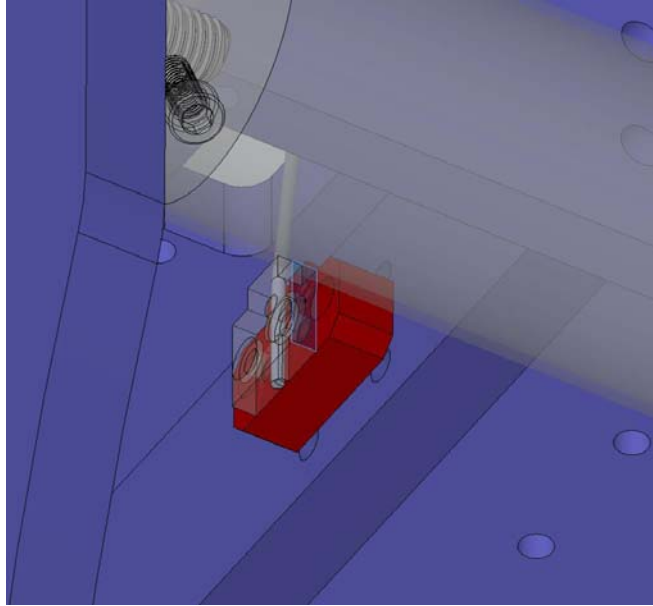


**Figure 8:** Optical Table ISC Side Shown



**Figure 9:** Optical Table - (Bottom View)

This view shows Safety Stops 4 pl. (eyes) these limit table travel in the event of a broken suspension wire. Also shown are Earth Quake stops, 2 pl. at left edge



**Figure 10:** Suspension Wire Clamp (4) Attach. to Telescope / Optical Table

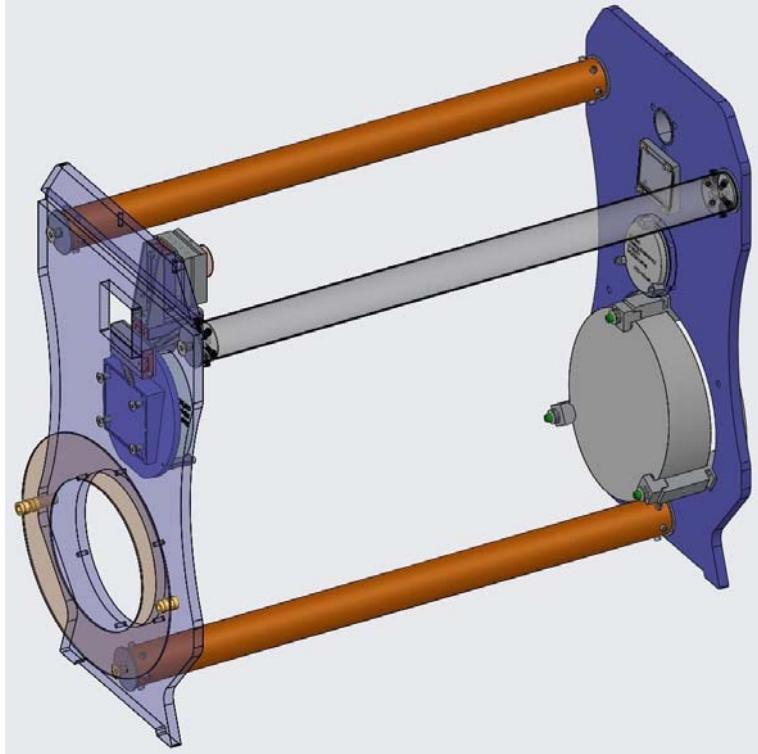
The optical beams can be handled by 2 inch diameter, or smaller optics (at 45 deg. angle-of incidence) on the ISC side of the platform.

#### ELECTRICAL CABLING

The TMS suspension will have stress-relieved electrical cabling run from the ISC side of the TMS platform up to the ISI platform. This includes providing appropriate non-contact routing and special clamping points for cabling within the suspension (cabling is provided by ISC).

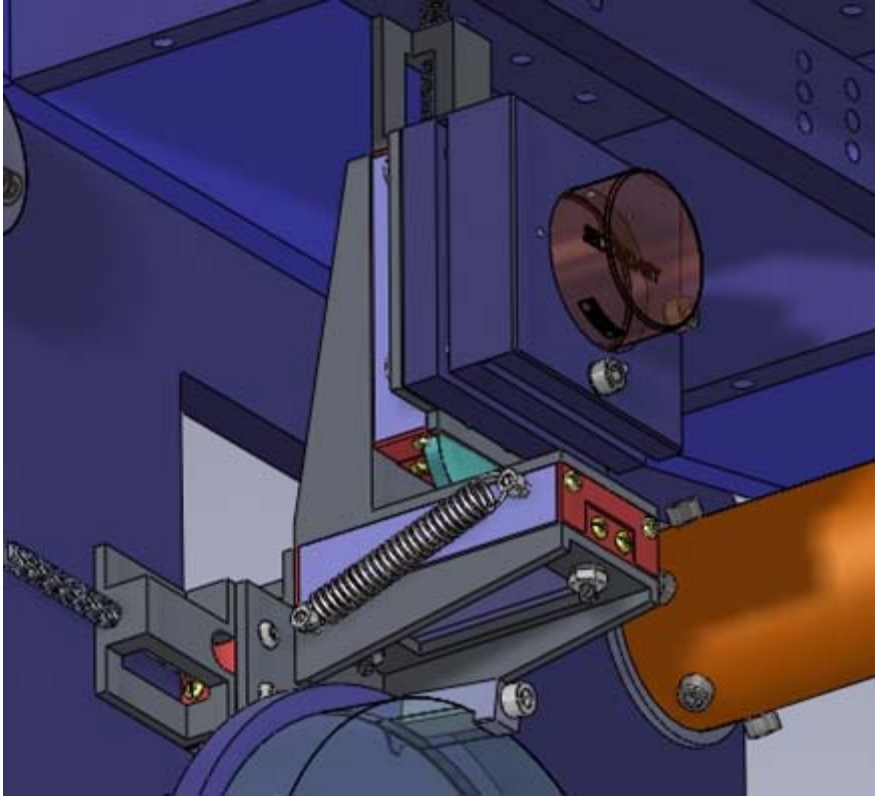


### 3.3 TELESCOPE (BRT) BEAM REDUCING TELESCOPE

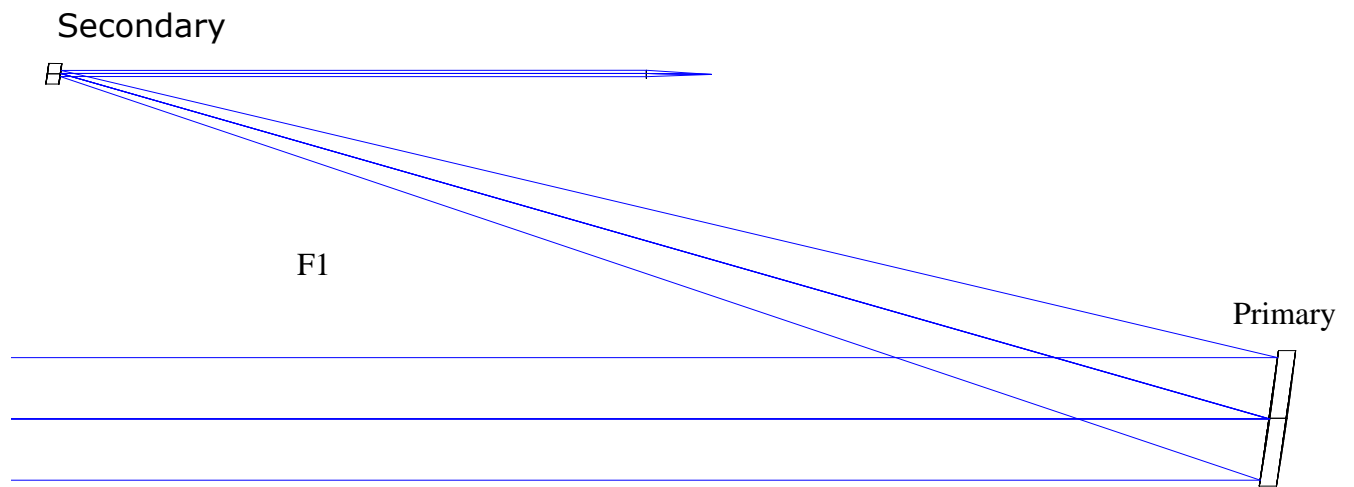


**Figure 11:** Telescope Structure with Optics, and front Baffle

The beam reducing telescope (BRT) must be able to be adjusted so that it delivers a beam with well-known beam parameters. The maximum clear aperture diameter is 190mm, this is the diameter of the electrostatic coating on the ETM. The telescope assembly has two aluminum end plates separated by three invar tubes. There are 4 optics total, two off axis parabolic mirrors and two flat folding mirrors. The primary mirror holder has 3 equally spaced flexure mounts, and is in an independent cell registered to the outside of the end plate (right), with self-centering flathead screws. The back plate surface is the reference plane for the telescope. The two fold mirrors are mounted with fixed location--the machining will set the angle within our tolerance. The two fold mirror surfaces are parallel. The off axis Primary mirror and Secondary mirror will provide a 20x reduction of the input beam diameter. The secondary mirror (focus element) can be positioned in three orthogonal axes by means of slide mechanisms that can be subsequently locked in place. (Figure 12) In addition, the secondary mirror will also be mounted in a two-axis flexure for steering to the correct angle. These adjustments will take up any tolerance in the manufacture of the Primary Mirror or the mirror mounting hardware.



**Figure 12:** Secondary Mirror Mount



**Figure 13:** ZEMAX model of off-axis parabolic telescope



### 3.4 OFF-AXIS PARABOLIC MIRRORS, MANUFACTURING TOLERANCE

Ref. Secondary Mirror Specification	E0900349-v4
Primary Mirror Specification	E0900347-v4

The surface irregularity of the parabolas is specified to be  $< 1/8$  wave @ 633 nm wavelength. This is equivalent to an irregularity of  $< 1/13$  wave @ 1064 nm.

The tilt tolerance of the mechanical axis of the mirror to the optical axis is  $\pm 0.0083$  deg.

The de-centering tolerance of the primary mirror is  $\pm 1$  mm, and the de-centering tolerance for the secondary mirror is  $\pm 0.3$  mm.

The focal length tolerance of the primary mirror is  $\pm 20$  mm.

The TYDEX corp. in St Petersburg Russia, will make first article set

## 4 TMS TELESCOPE ALIGNMENT PROCEDURE

### 4.1 SECONDARY MIRROR TRANSLATION AND TILT CORRECTION

Satisfactory alignment of the telescope can be accomplished by moving only the secondary mirror in five degrees of freedom—tilting in pitch and yaw, decentering vertically and horizontally, and moving along the optical axis for focus.

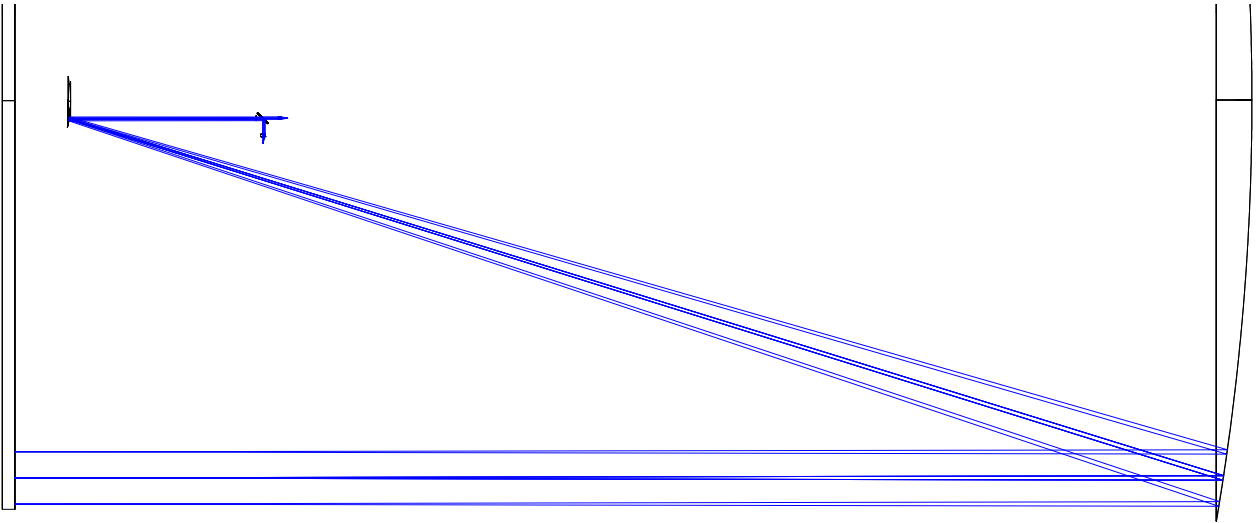
The primary mirror will be placed in a fixed mirror mount whose mechanical axis is pre-aligned to within 0.1 mrad of the reference optical axis of the telescope. The rms combined error of the mirror mount and the tilt error of the primary is 0.01 deg.

The secondary mirror has the necessary degrees of tilt and translation freedom.

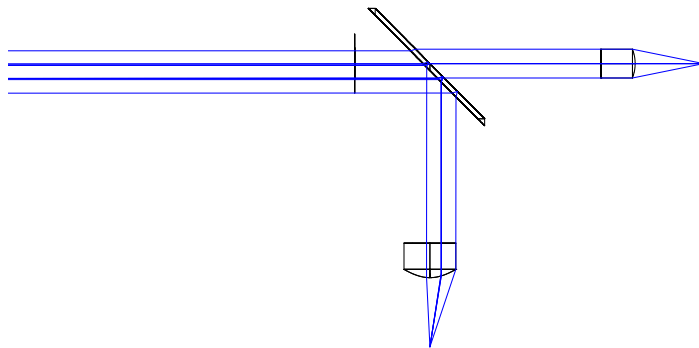
### 4.2 AUTOCOLLIMATOR AND SHACK-HARTMANN INSTRUMENTS

Either an autocollimator beam, or a collimated light source, such as a laser or a super luminescent diode, will be injected into the secondary end of the telescope along the optical axis, as shown in (Figure 14). The beam will reflect from a mirror when it emerges from the primary mirror and be reflected back through the telescope and emerge after a round trip at the secondary mirror.

The beam splitter shown in the enlarged view will reflect a portion of the return beam to the cross-hairs of the autocollimator or to the Shack-Hartmann wave front sensor. (Figure 15)



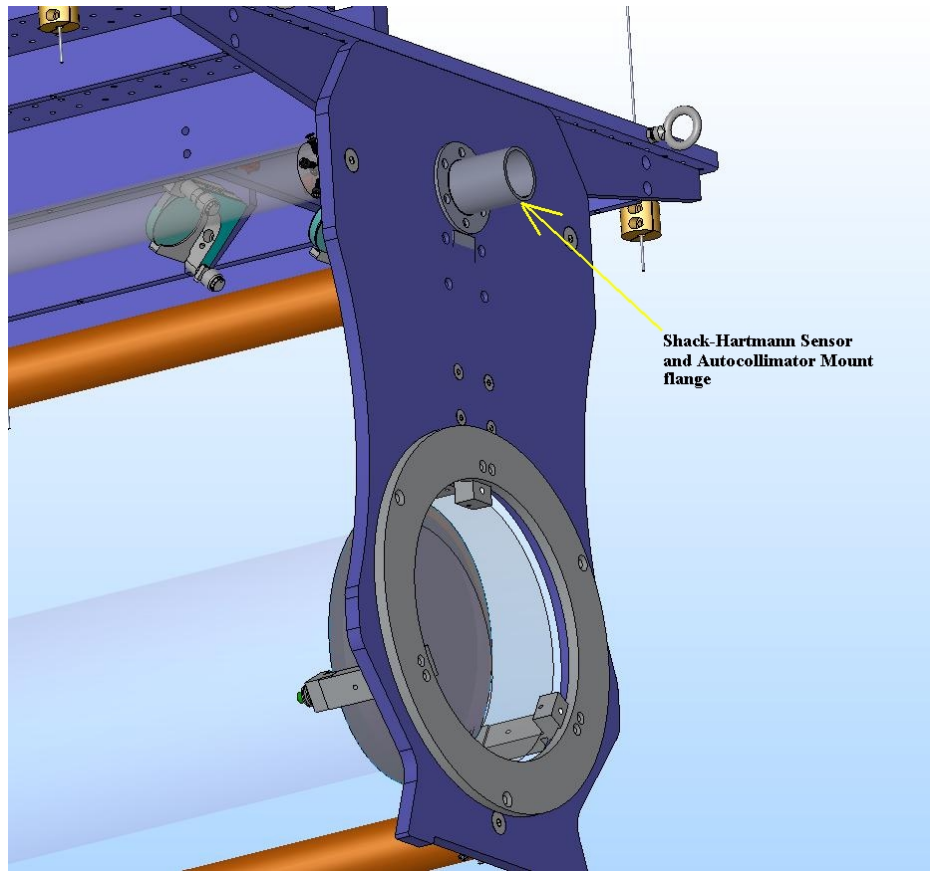
**Figure 14:** Double Pass Alignment Beam



**Figure 15:** Alignment Beam Splitter

### 4.3 BEAM SPLITTER

This is for the autocollimator, or for Shack-Hartmann sensor initial mechanical alignment of primary and secondary mirror mounts



**Fig 16:** Shack-Hartmann sensor / Auto Collimator Flange Mt.

The ETM Telescope structure uses the plate to which the primary mirror mount attaches as a reference surface whose normal defines the input and output optical axes of the telescope. The primary and secondary mirror mounts are pre-aligned parallel to the reference surface.

#### **4.4 COARSE ALIGNMENT WITH AUTOCOLLIMATOR**

During this procedure, the secondary mirror will not be tilted.

Focus is achieved by moving the secondary mirror until the returned reticule pattern seen in the eyepiece of the autocollimator has sharp edges.

When initial focus is achieved, it will be observed that the reticule pattern is not centered with the crosshairs of the autocollimator, which have been set coincident with the optical axis of the telescope. Next, the telescope beam will be aligned with the optical axis by translating the secondary mirror transverse to the beam until the Reticule pattern is centered on the cross hairs.

The focus and beam pointing steps are iterated until the Reticule pattern is visually in sharp focus and is centered on the cross hairs.

#### 4.4.1 Initial Misalignment Conditions

The ZEMAX wave-front map shows the initial aberrations of the wavefront of the telescope beam with the following worst case combination of tilt and decenter errors of the primary and secondary mirrors:

Primary

tilt            0.01 deg

decenter      1 mm

Secondary

tilt            0.01 deg

decenter      -0.3 mm

Defocus        -20 mm

#### 4.4.2 Telescope Mounting to Table

Telescope is attached to the Optical Table in three places with cap screws and spacer washers. The invar tubes separating the telescope end plates reduce the expansion and separation of the two end plates to approx 1800 $\mu$ m over 5deg temperature change with 2400 $\mu$ m allowed. The difference in expansion of the telescope vs the Optical Table is taken up by a flexure above the invar tubes in the input side of the telescope.

#### 4.4.3 Total number of Assemblies

A Total of 6 Assemblies will be installed 4 at LHO AND 2 at LLO,, and 1 complete spare unit built, a total of 7 systems. Each site will have a set of assembly and installation tooling, and a temporary structure (Servicing Tooling) to allow stabilization of the TMS, for servicing of the ETM. The structure will permit moving the telescope and optical table back to clear a working space between the ETM, and telescope assembly while providing slack in the suspension wires.

### TRANSMISSION MONITOR SUSPENSION (TMS)

Naming Conventions 5-20-2010

T0900488-v3

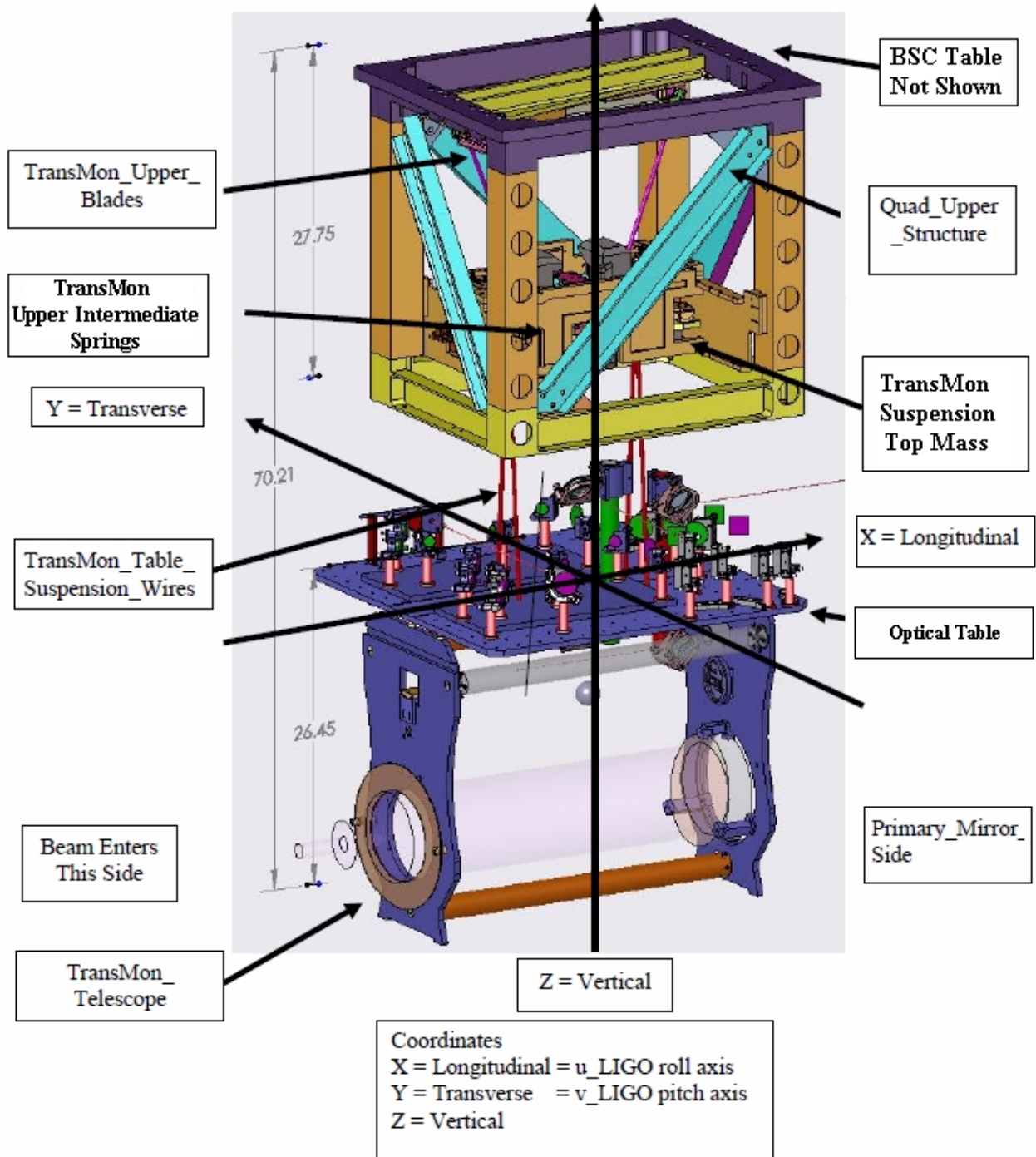
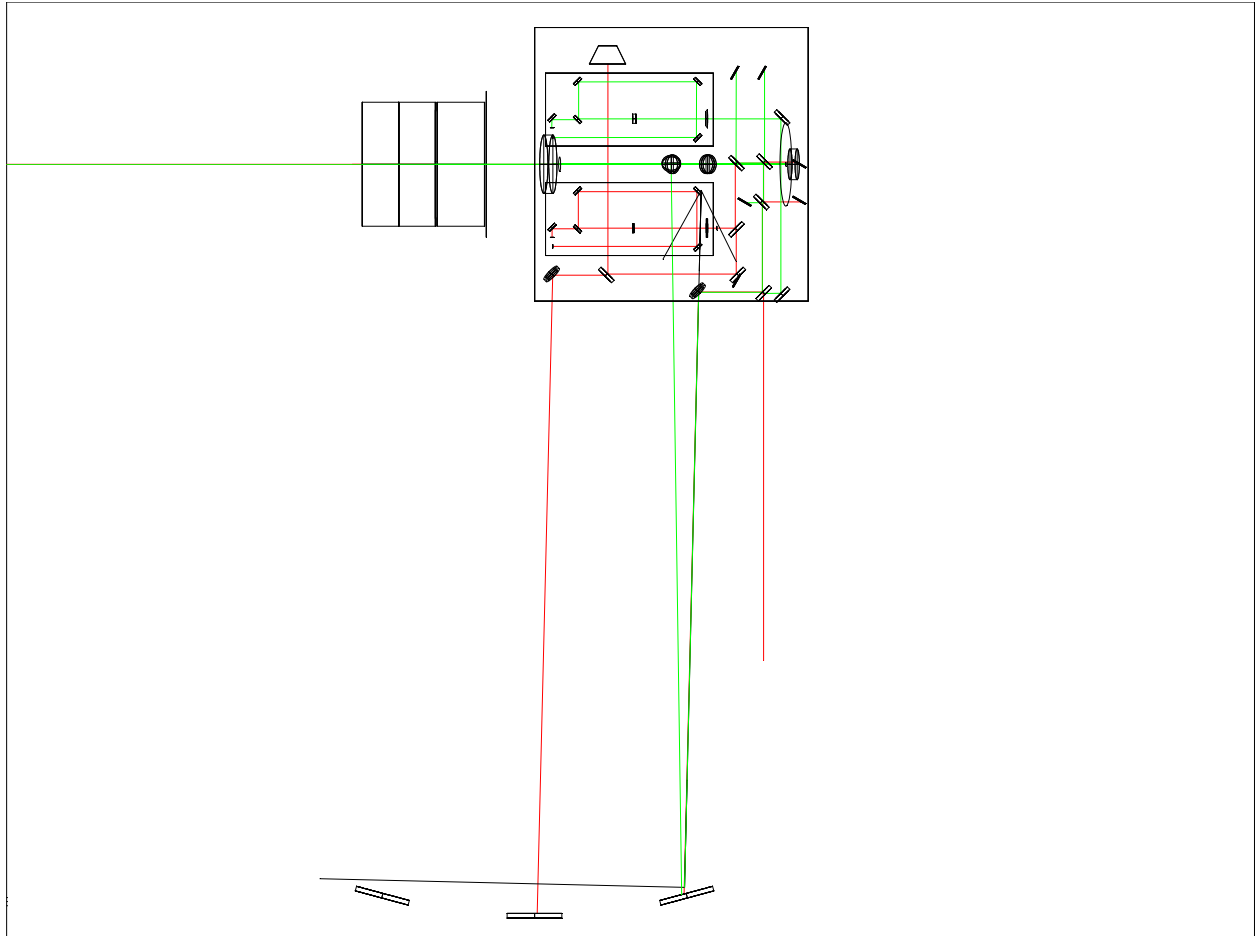


Figure 17: Naming Conventions

## 5 TMS OPTICAL LAYOUT

### 5.1 ZEMAX OPTICAL LAYOUT PLAN VIEW

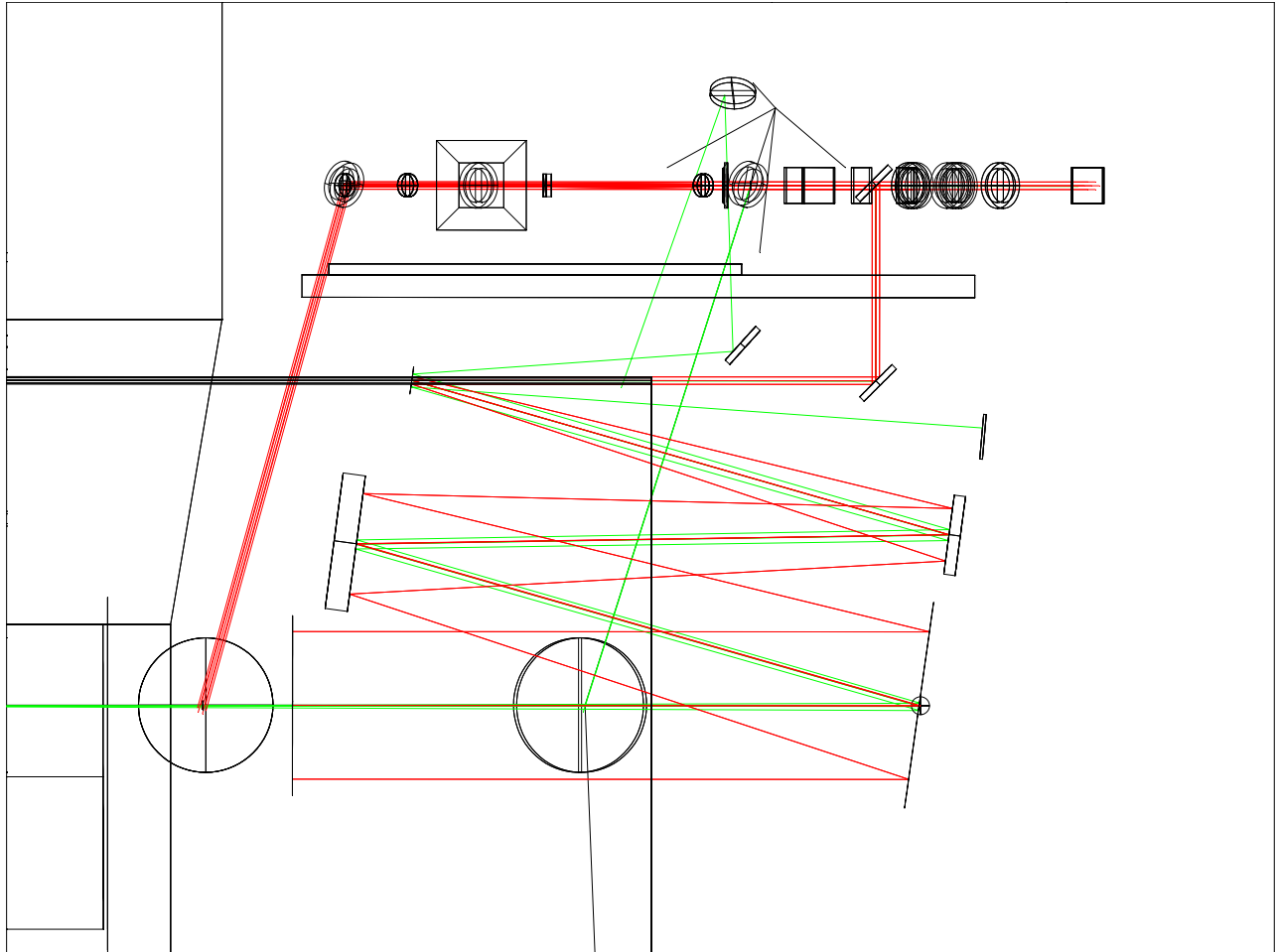


**Figure 18:** Plan View Layout of the TMS Optical Table and the Input and Output TMS and Beam

A plan view of the TMS table with the 1064 nm beam optical path in red and the 532 nm optical path in green is shown in Figure 18.

## 5.2 ZEMAX LAYOUT ELEVATION VIEW

A preliminary ZEMAX design layout of the TMS Suspension with the ETM Telescope placed below the TMS optical table is shown in Figure 19



**Figure 19:** TMS Telescope Beams

The Hartmann (green) reference beam exits the telescope above the 1064 (red) ETM transmission beam.



## 6 TELESCOPE ALIGNMENT PROCEDURE

The purpose of this technical note is describe an alignment procedure for the ETM Telescope that uses a combination of an autocollimator for initial coarse alignment, and a Shack-Hartmann wave-front sensor for the final fine alignment. The telescope is part of the TMS Suspension System for aLIGO.

### 6.1 ZEMAX MODEL

#### 6.1.1 SHACK HARTMANN WAVEFRONT SENSOR

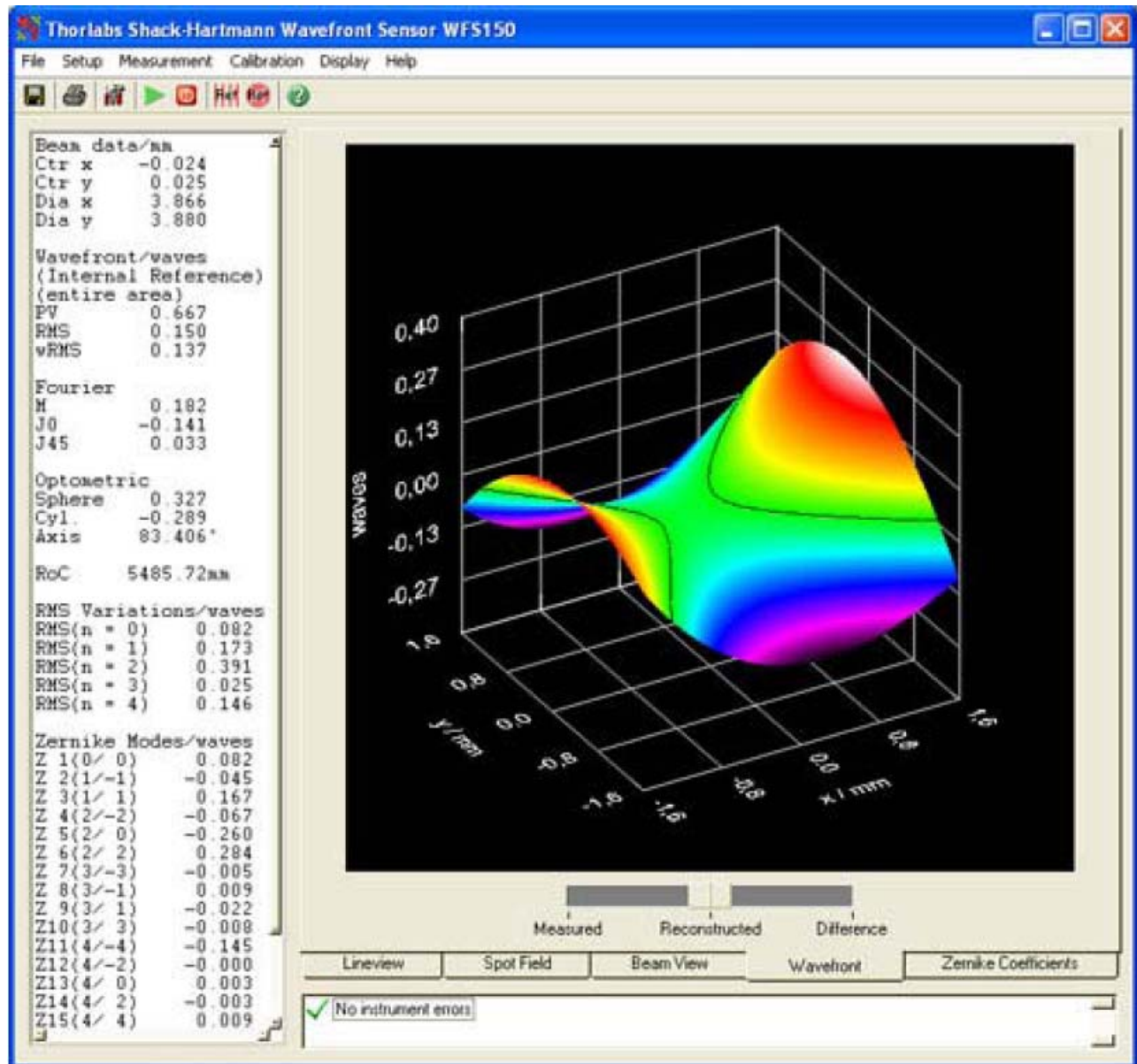
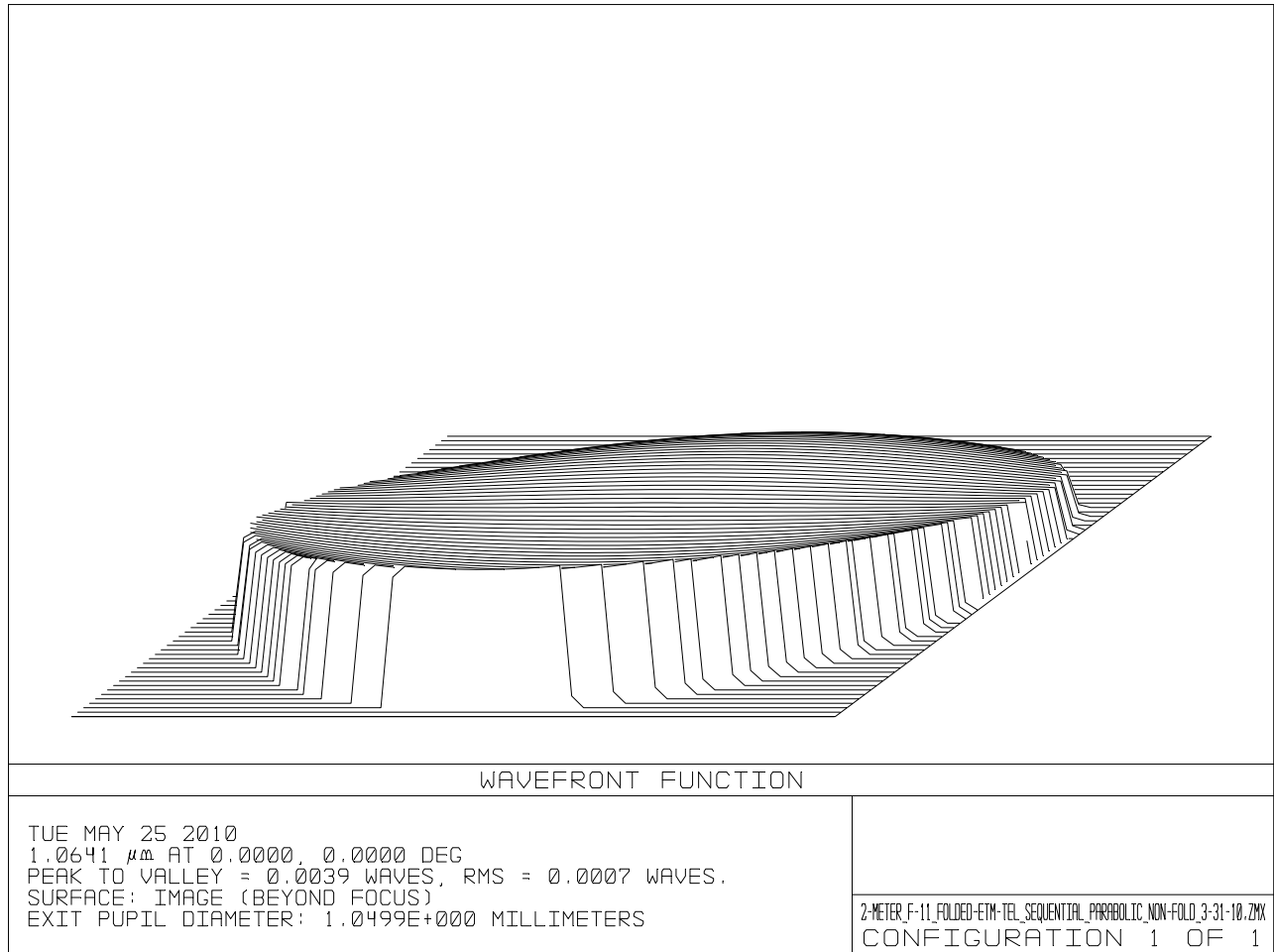


Figure 20: Wavefront Map from Shack-Hartmann Sensor

### 6.1.2 WAVEFRONT ABERRATION



**Figure 21:** Wavefront Aberrations after Alignment Using Five Degrees of Freedom of Secondary Mirror

### 6.1.3 ELLIPTICITY AND WAVEFRONT ABERRATION

The output spot ellipticity and the wavefront aberration of the telescope are summarized in T1000275-v1

## **7 TMS CONSTRUCTION**

### **7.1 MATERIALS**

We will comply with, LIGO-E960050-v4 no special material considerations using polymers approved for SUS in the same applications (e.g. Osems , wire )

### **7.2 PROCESSES**

We will comply with [LIGO-E0900048-v5](#) there will be no special welding considerations or other special processes required.

### **7.3 CLEANING**

We will comply with E960022; there will be no special cleaning considerations.

### **7.4 COMPONENT NAMING**

All components shall be identified as required in E030350-v2. This shall include identification (part or drawing number, revision number, serial number) physically stamped on all components, in all drawings and in all related documentation.

### **7.5 INTERCHANGEABILITY**

Interchangeability is not required in this assembly although the majority of parts will be interchangeable as a result of the tight manufacturing tolerances.

## 8 TMS CHAMBER LOCATIONS (LHO / LLO)

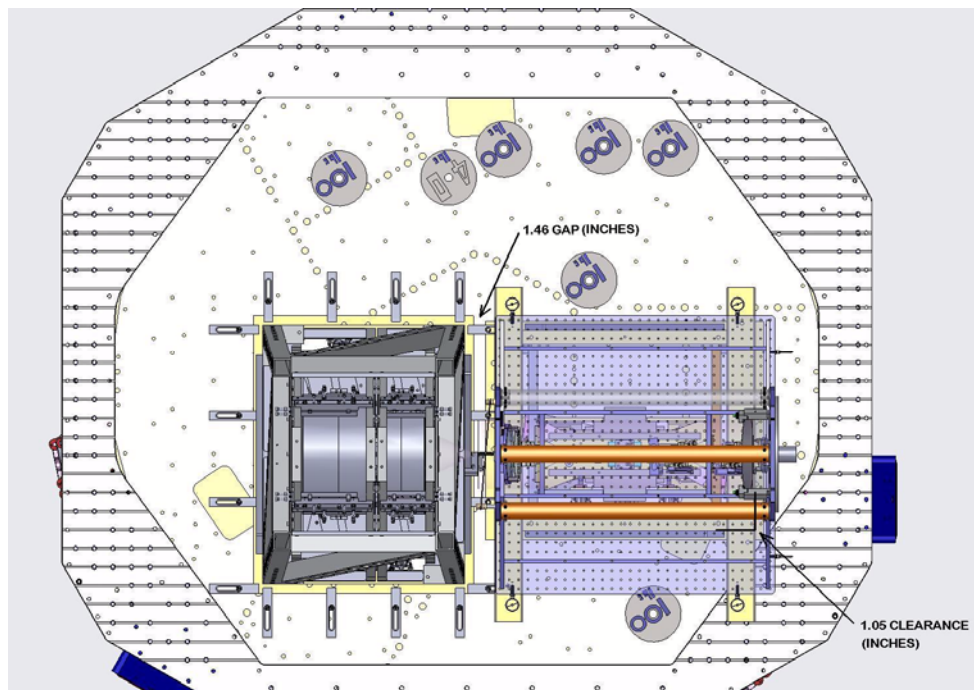
### 8.1 H1 & H2 AT HANFORD, L1 AT LIVINGSTON

TMS\_SUS systems will be installed in BSC 5/6-H2 and BSC 9/10-H1 at LHO, and in BSC 5/6-H1 at LLO.

The suspension structure top springs in the main frame have an offset that moves the frame to one side allowing clearance between the suspension frame and the '0' stage ring. The frame clears the BSC table ring in each installation shown below.

The ETM quad suspension shown in relation to the TMS structure has approx. clearance of 4 1/2". The TMS suspension at the lower right corner clears the BSC table ring.

VIEWS 22-24/26 ARE LOOKING UP SHOWING CLEARANCE BETWEEN '0' STAGE AND TMS SUSPENSION FRAME. THE ETM AND TMS FRAMES CLEAR TO ALLOW CLAMPS BETWEEN THEM.



**Figure 22: BSC-5-H2 (HANFORD ONLY)**

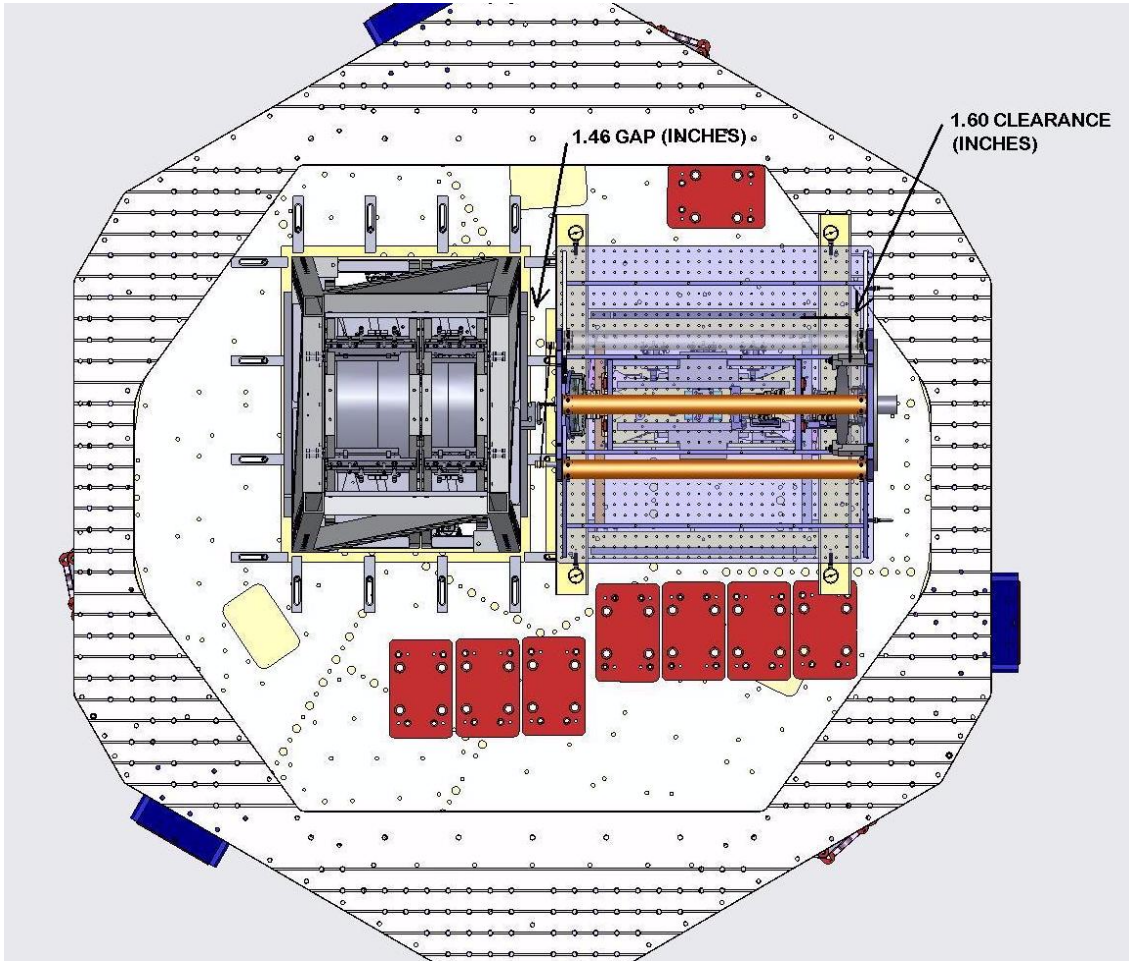


Figure 23: BSC-6 H2 (HANFORD ONLY)



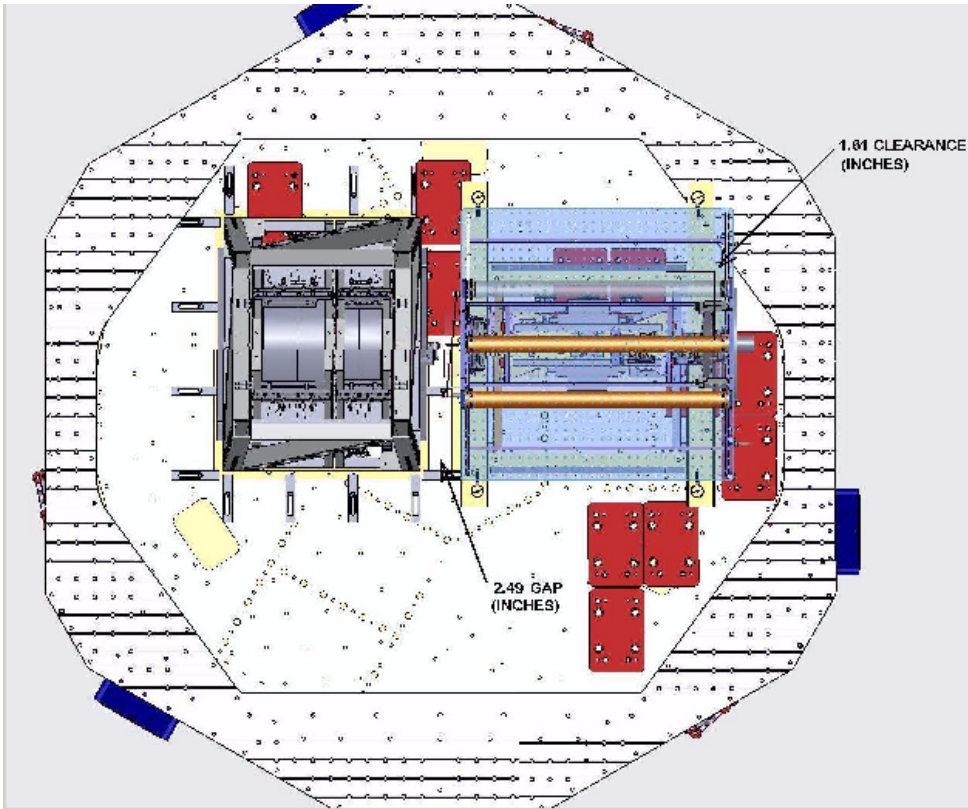


Figure 24: BSC-9-H1 & L1 (Hanford and Livingston)

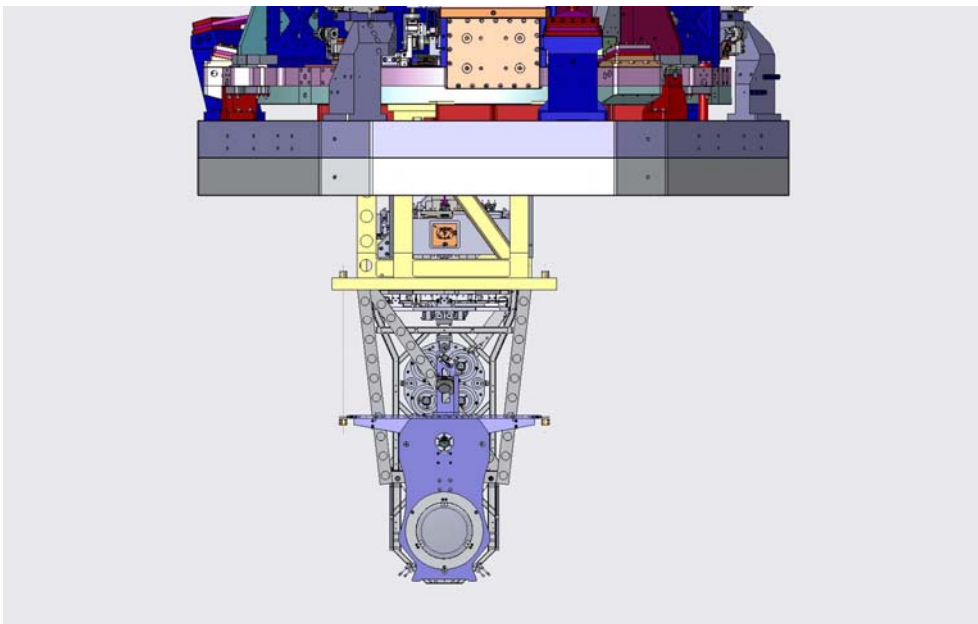


Figure 25: BSC-9-H1 & L1 (End View Primary mirror side)

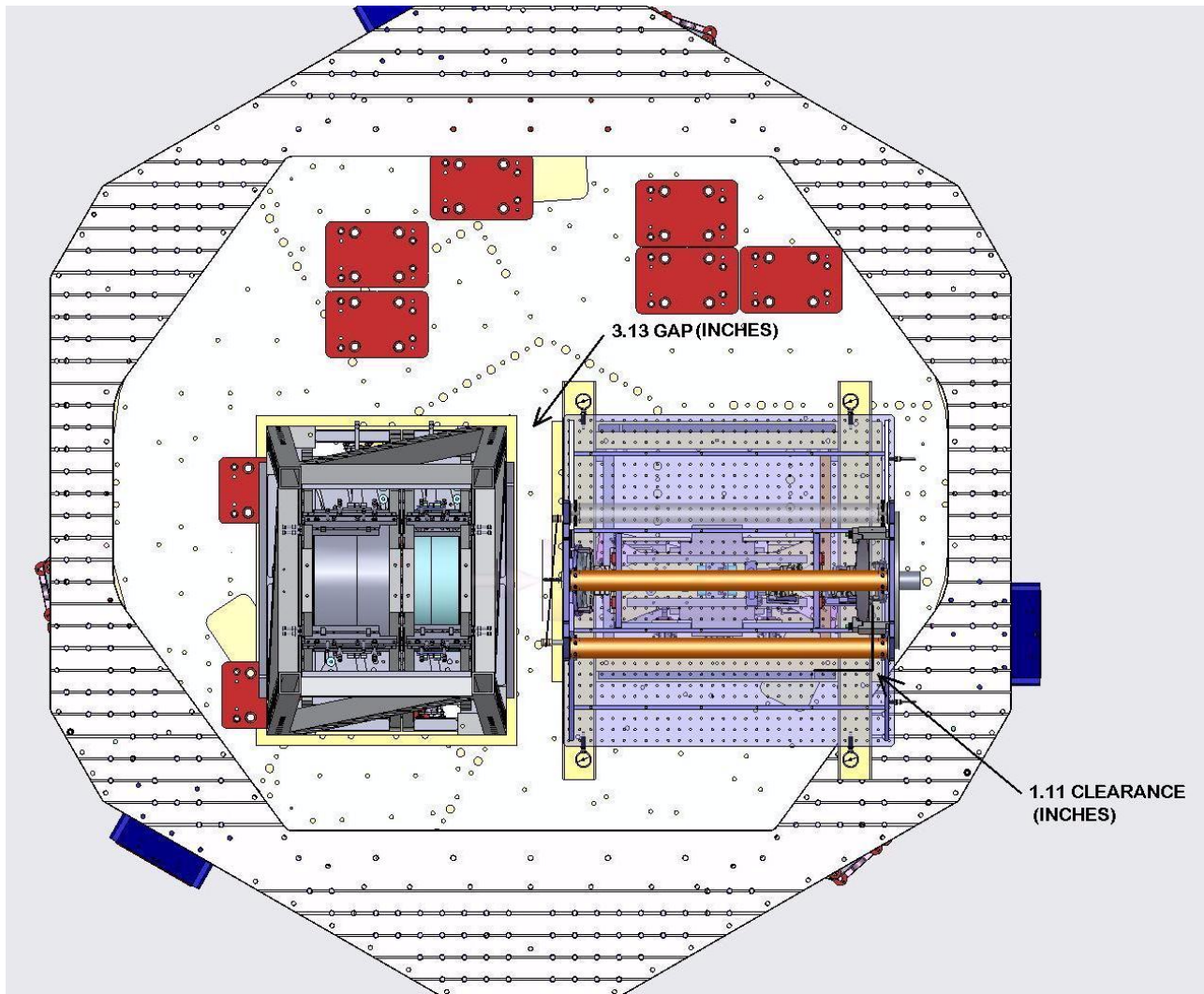
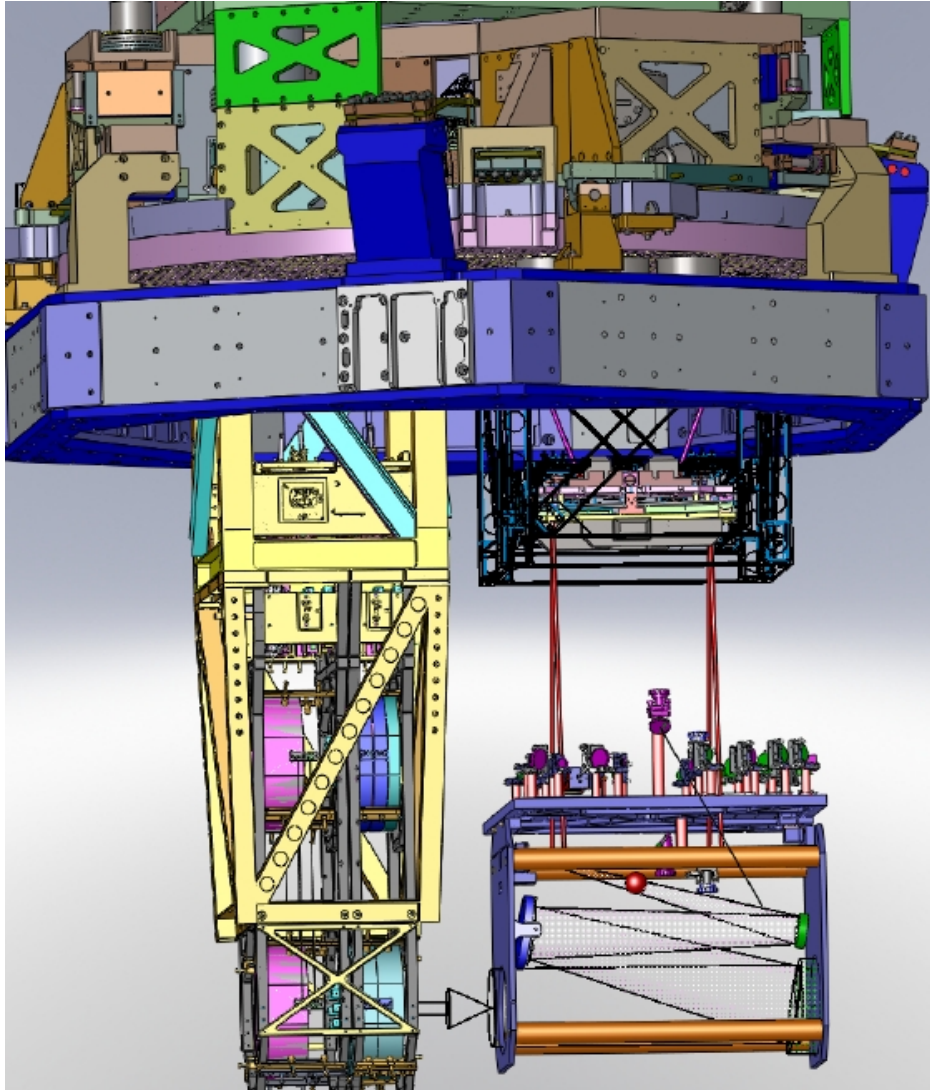


Figure 26: BSC10-H1 & L1 (Hanford and Livingston )

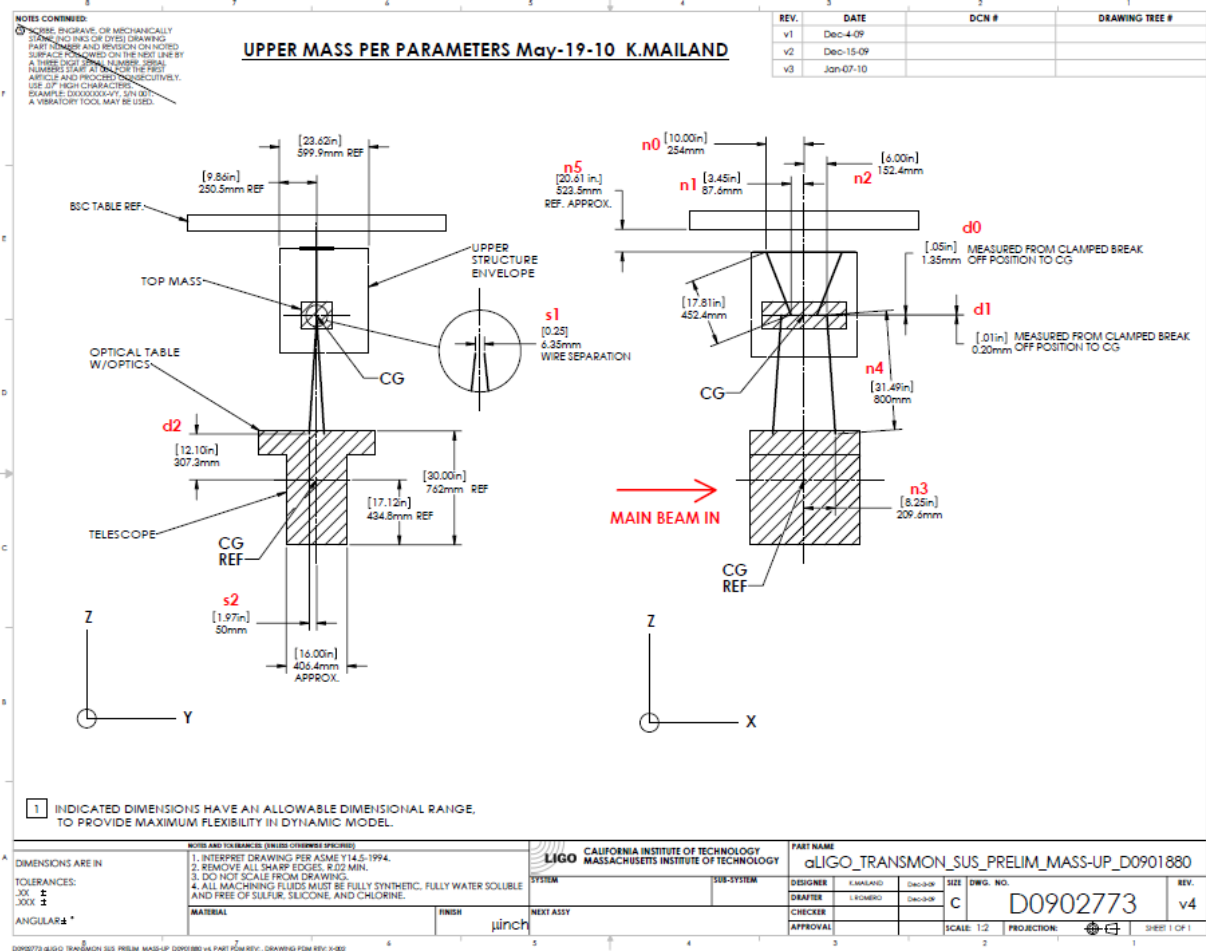


**Figure 27:** TMS Suspension with ETM @ Left a minimum of 4.5" clearance between TMS Telescope Frame and ETM frame

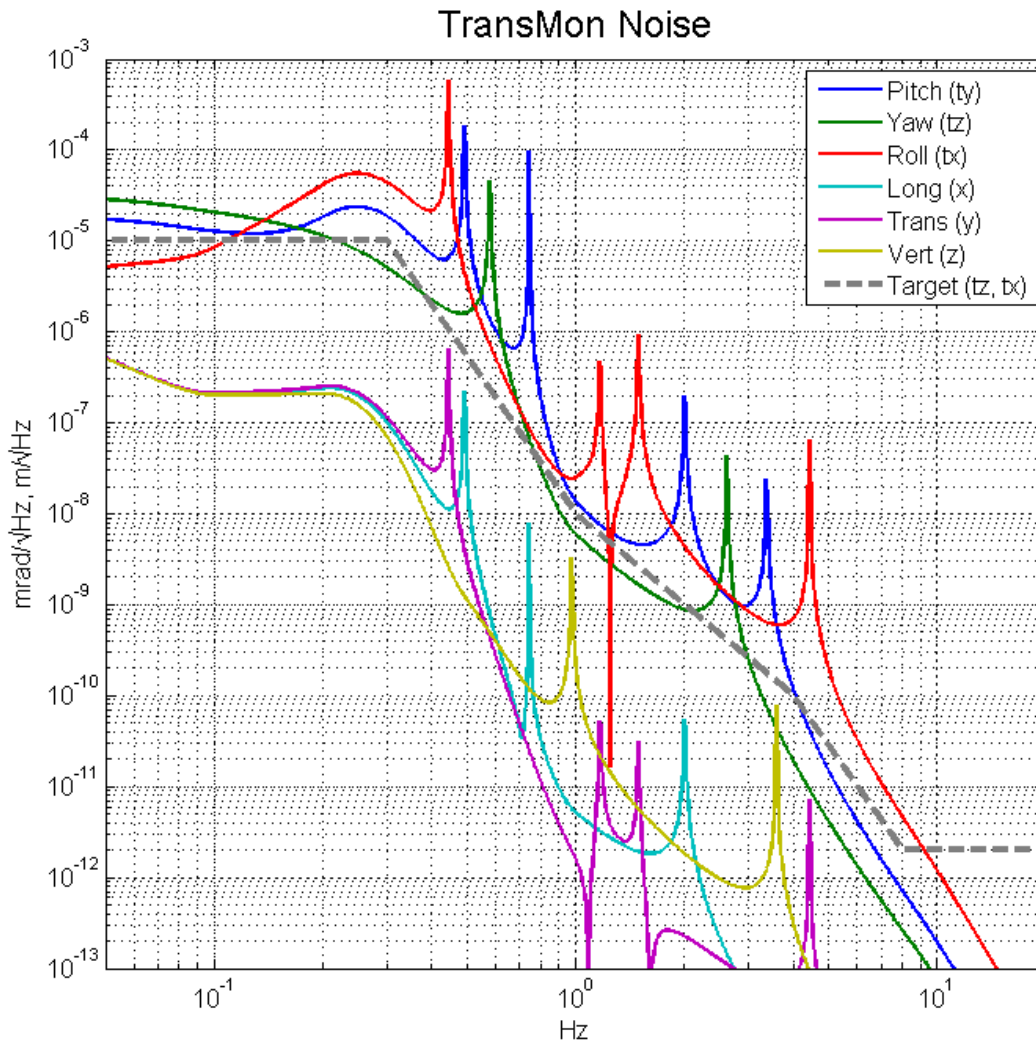


## 9 TMS PERFORMANCE CHARACTERISTICS

Using the dimensions, in (Figure 28) and a dynamics model: T1000263 by Mark Barton, and estimated BSC ISI table motion, we have computed the resulting displacement spectra of an undamped TMS suspension. Modest damping will reduce the resonance peak heights, bringing us close to the performance target at all frequencies (Figure 29). More details on the model and the input noise estimates can be found in section 9.1



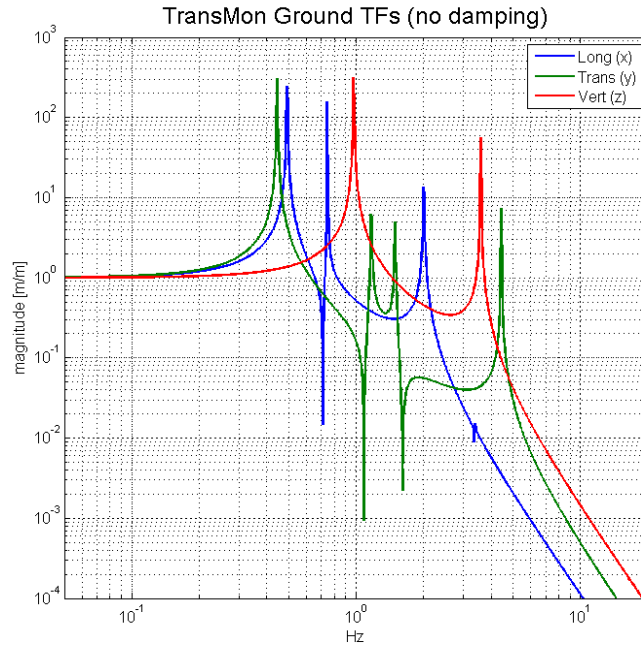
**Figure 28:** Parameters Drawing D0902773 v4 showing suspension wire and TMS telescope and optical table cg locations



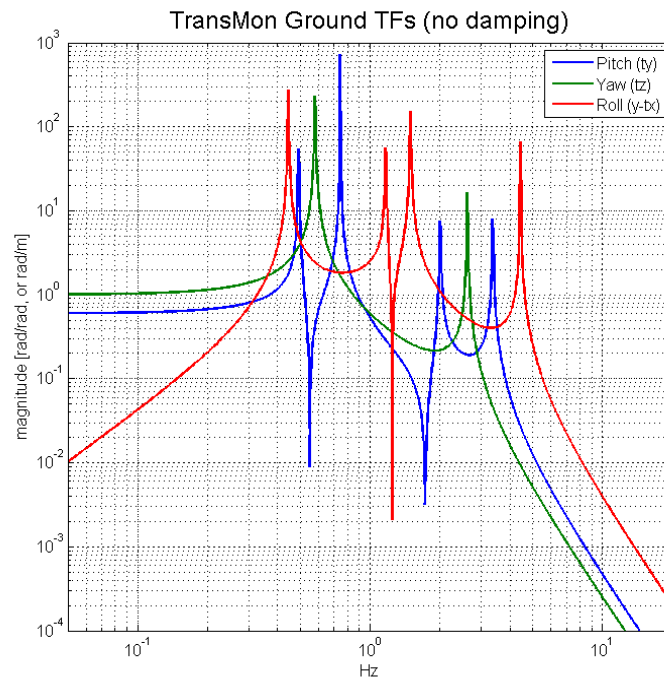
**Figure 29:** Estimated displacement and angular noise spectra for the TMS. The target (dashed grey line) refers only to the pitch and yaw (ty and tz) degrees of freedom. The resonances are left un-damped in this model to facilitate identification of their frequencies, though damping will be present in the actual system.

## 9.1 TRANSFER FUNCTIONS AND INPUT NOISE

Displacement transfer functions, shown in (Figure 30-31), show the transfer of “ground” motion (actually the BSC ISI) to the TransMon table. These transfer functions are computed without damping loops to better show the resonance frequencies of the suspension. The ISI table motion spectra used as the input to produce the noise spectra in the previous section is also shown (Figure 32).



**Figure 30:** TMS Ground to Displacement Transfer Functions (no damping). These transfer functions are of little interest to the noise performance, but should be helpful in characterizing the suspension, and in constructing control and damping loops.



**Figure 31:** TMS Ground to Angle Transfer Functions (no damping). Note that the dominant transfer to  $t_y$  is from  $y$  rather than  $t_y$ , so this transfer function is shown instead.

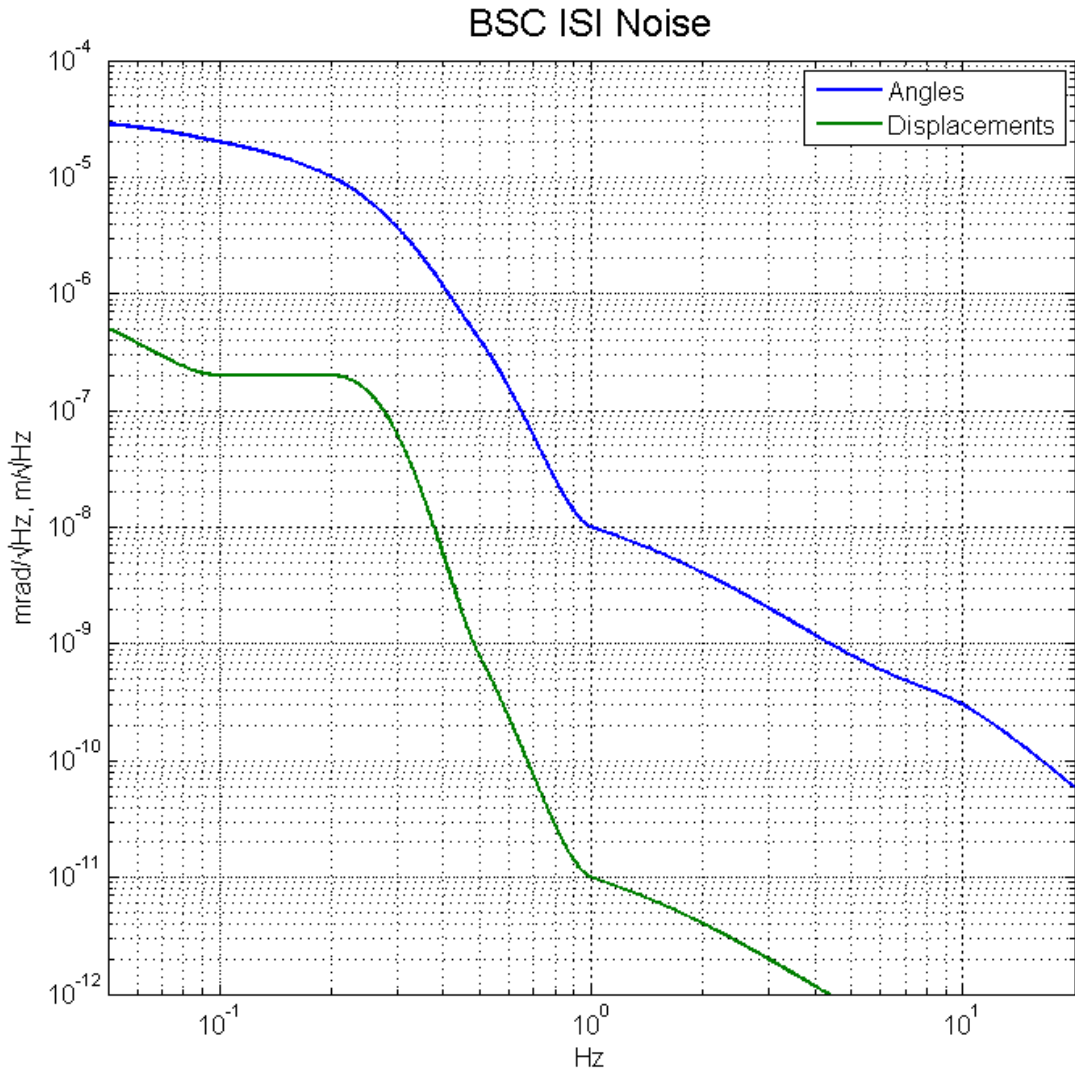
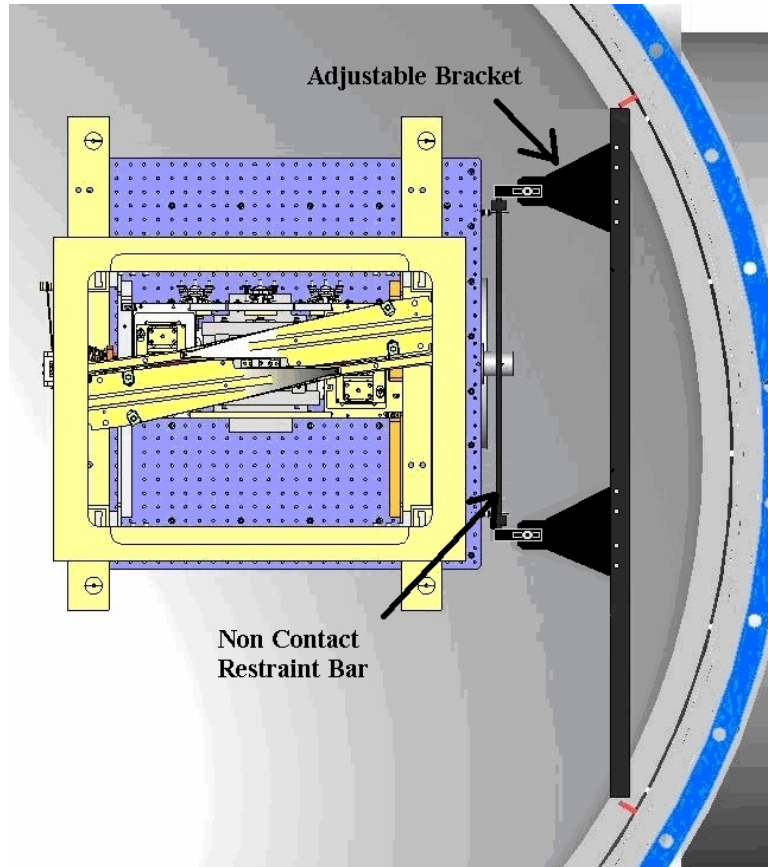


Figure 32: Displacement noise from the BSC ISI used as input to the model.

## 10 TMS FAULT DETECTION, ISOLATION AND RECOVERY

### 10.1 EARTH QUAKE STOPS

There will be passive earthquake stops that minimize motion of the suspended TMS Assembly. The earthquake stops prevent any contact between the TMS and the ETM quad suspension. The earthquake stop rod does not contact the suspended platform, it is centered in the eye ring on the Optical Table.



**Figure 33:** Earthquake Restraint Typ.

### 10.2 METHOD OF IMPLEMENTING

Earthquake stop Design will be an attachment to the Chamber wall utilizing existing brackets, with mounts that support a rod extending thru eyes located at the end edge of the optical table. In normal operation these will not contact the suspended TMS assembly. This arrangement limits travel motion of the suspended mass and will not interfere with system controls.

### **10.3 SOFTWARE WATCH DOGS**

These will be the same as Suspensions.

## 11 INTERFACE CONTROL

### 11.1 THE TMS TELESCOPE ASSEMBLY

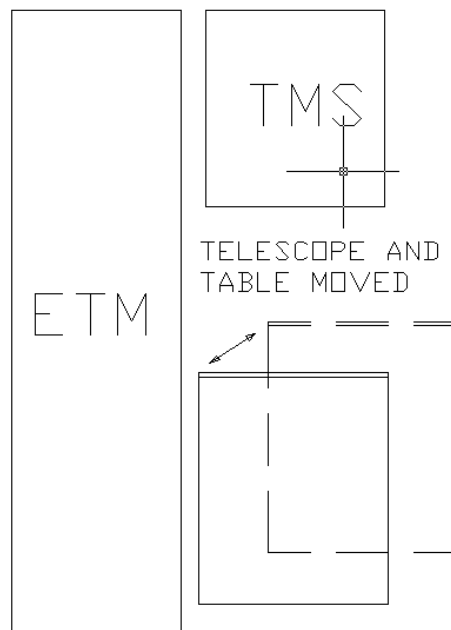
The TMS Assembly and Optical Table Assembly will be offset from the ETM frame assembly by approx 4-5" in normal operation. This will not be enough access clearance to service the ETM in all instances. will need to be moved back approximately 12" to allow front access to the ETM. There will be a fixture that will allow temporary repositioning of the TMS Telescope.

### 11.2 THE TMS TELESCOPE ASSEMBLY SERVICE FIXTURE

The fixture will consist of a structure that attaches to the internal BSC table or '0' Stage and has a slide and jacks attached, this will lift and move the TMS back (away) from the ETM. The lift and back relocation will not require the suspension wires to be removed or readjusted. (Figure 34)

### 11.3 THE FIXTURE ATTACHMENT AND REPOSITIONING OF TMS

The Structure as described above can be attached to the table or support ring '0' Stage with brackets, optionally attached to the TMS structure all will use standard hardware with existing tapped holes.



**Figure 34:** The service tooling will allow the telescope and optical table to be moved away from the ETM for accessibility.

## **11.4 ELECTRONIC CABLES AND CONNECTORS**

The connectors and cables will be constructed of approved materials and be strain relieved. The construction will be done with concern to the flexibility of the cable in the interface to the suspended components. OMC uses flexible wires to the table, they are the responsibility of the ISC group.



## **12 RELEVANT RODA CHANGES AND ACTIONS COMPLETED**

There are no relevant RODA's

## **13 INSTALLATION AND INTEGRATION PLAN**

See Document E1000097-v1 'ETM' (TMS) Transmon Telescope and Suspension Installation Plan.

## **14 FIRST ARTICLE ASSEMBLY AT CIT**

### **14.1 THE TELESCOPE AND SUSPENSION**

The first article assembly will take place in the lab room at 318 Downs. The seismic testing will also be done there.

### **14.2 PRE ASSEMBLY AND ALIGNMENT AT THE SITE**

We will be assembling the first article at CIT initially then sending to site for cleaning and re-assembly.

Assembly of the TMS Telescope, Optical Table, and SUS at the site:

These TMS assemblies will be accomplished in advance of the needed installation date, and therefore clean storage for the sub assemblies will be needed.

At the Hanford Observatory the TransMon Telescope, Optical Table, and SUS will be individually assembled and aligned in series using individual clean facilities.

The TransMon Telescope and Optical Table will be mated and aligned using tooling made for this task in a clean room next to the Cartridge assembly, while hanging by wires from a temporary fixture to simulate the same stress the assembly will see as when it is installed on the ISI Table on the cartridge.

This operation should take place prior to the attachment to the cartridge, using the finished stored sub-assemblies.

### **14.3 LOADING THE TMS ONTO THE CARTRIDGE**

TMS will be loaded onto the cartridge and pre aligned to the ETM for installation into BSC Chamber.

Procedure:

1. Use a Genie Lift to roughly position the suspension frame assembly to the ISI optical table in the cartridge.
2. Precision-locate the suspension frame assembly to the ISI optical table, using pusher tooling.
3. Secure the suspension frame assembly with clamps.
4. Attach the telescope and table installation tooling to the suspension frame, and table. (Figure 35 )
5. Use the Genie Lift to support and position the Transmon Telescope assembly, and attach to the installation tooling.

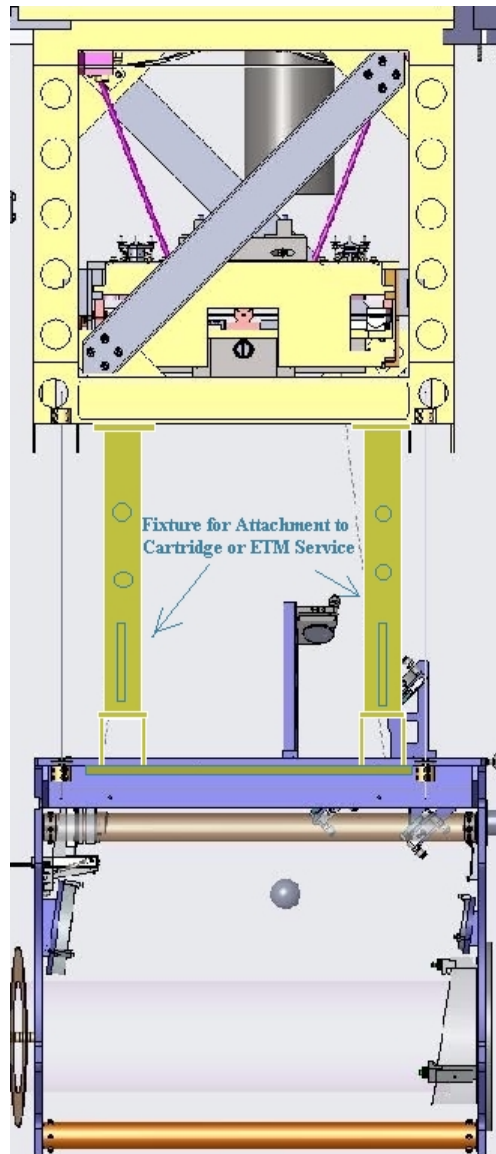
6. Connect the suspension wires from the suspension frame to the TMS Telescope assembly.
7. Remove the installation tooling.

**Tooling:**

Support Tooling will be attached to the Telescope Optical Table assembly; to relieve the suspension springs and wire loading during installation.

**Weight Specification:**

1. The telescope and Optical Table combined weight is 80kg.
2. The suspension frame and top mass weight is approx. 80 kg



**Figure 35:** Tooling to fix the TMS telescope to the Suspension frame

## **14.4 FINAL ALIGNMENT / TOOL SETUPS**

### **Alignment Procedure After Cartridge Installation in the BSC:**

1. Enable active suspension control, to verify the installation is within the control range.
2. Align the TMS TransMon Telescope SUS to the ETM HR surface, using a test laser beam apparatus, described in **(4.2)**
3. If the TMS assembly is not within the control range the suspension frame will be repositioned on the table.

## 15 ESTIMATE OF TIME AND PERSONNEL TO COMPLETE TMS ASSEMBLY

### 15.1 EQUIPMENT

The TMS assembly task involves moving the large size and weight of the sub-assemblies, some handling will have to be done with the assistance of tooling, fixtures and lifts, specific to the task.

### 15.2 PERSONNEL

There will be 2-3 people required to do the installation preparation tasks; a genie lift will be necessary for the attachment of the TMS SUS to the cartridge, and the attachment of the TMS Telescope and Optical Table to the TMS Suspension. The TransMon Telescope and Optical Table will be supported during the move to the BSC by stabilization tooling. (Figure 35)

#### 15.2.1 TIME EST.

1. SUS assembly	2 people 4 days each
2. Optical Table	2 people 4 days each
3. TransMon Telescope	2 people 4 days each
4. Joining of Optical Table and (TMS) Telescope	2 people 4 days each

#### 15.2.2 CARTRIDGE ASSEMBLY OF THE TMS

Cartridge Assembly and alignment	3 people 4 days each
----------------------------------	----------------------

#### 15.2.1 TMS ALIGNMENT TO ETM IN BSC

Chamber alignment	2 people 4 days each
-------------------	----------------------

## **16 LONG LEAD PROCUREMENTS**

### **16.1 TELESCOPE**

Note: B-Osems will be provided by the UK in sufficient quantity for the TMS needs see E1000042-v1

#### **16.1.1 PRIMARY MIRROR**

Approx 7 months for 6 units

#### **16.1.2 SECONDARY MIRROR**

Approx 6 months for 6 units

#### **16.1.3 SUSPENSION**

Maraging Steel Springs and processing. The TMS system will use existing drawings and may reproduce parts in the US. Lead time may be 6 months

The structural frame Lead time may be 6 months

### **16.2 OPTICAL TABLE**

Lead time may be 3 months

#### **16.2.1 OPTICAL TABLE COMPONENTS**

These have nominal lead times none more than 6 months, and provided by ISC.

## **17 TECHNICAL, COST AND SCHEDULE RISKS AND PLANNED MITIGATION**

- Getting the First Article delivered to the Hanford in time for the Long Arm Test.
- Aligning, focusing and maintaining the alignment of the telescope
- Moving beam block in vacuum on an isolated table
- Aligning the telescope to the arm

The optics for first article can be ready in advance of the timeline for hardware assembly for bench test. The mechanical parts are standard machining and predictable for cost and completion. Other risks will be mitigated by steps taken in response to the first article setup experience.

### **17.1 PER RISK REGISTRY M080359-V5**

No TMS risks are indicated in the risk registry.

## **16.2 PROBLEMS AND CONCERNS**

### **16.2.1 SUSPENSION CONCERNS**

1. Single source for the B-osems for suspension controls (schedule / cost risk) risk is minimal, we have enough extras from orders for the same part for the suspensions.
2. TMS Suspension Hybrid meeting the control requirements (schedule risk) minimal risk the control system is nearly identical to the proven Quad system.

### **17.1.2 OPTICAL TABLE CONCERNS**

1. The Thermal stability re. the beam dump conducting into the optical table plate moving the telescope causing Horizontal angle change (schedule risk) (Eric and Sam agree this is not an issue of concern based on the power dissipated and the limited interface heat path to the optical table.



## 18 TEST PLAN OVERVIEW

### 18.1 SUSPENSION SEISMIC TEST AT CIT

#### Ref . T1000236-v1

1. Seismic Attenuation Characterization -Validation of the suspension mathematical models to the measurements using the OSEM position sensors

2. Active Control System Characterization -Open loop transfer function measurements for control laws characterization

Validation and fitting of the suspension mathematical models to the measurements using the OSEMs to predict the seismic attenuation below the internal model frequencies

Transfer function measurement using impulsive excitation(hammer) to try to characterize the high frequency transmissibility of some of the DOFs

**Active Control System Characterization** For this type of measurements we will require the standard aLIGO digital control system used for the quadruple pendulum control.

Open loop transfer function measurements for control laws characterization

Impulsive response measurements for control laws characterization

step response measurement for telescope pointing characterization

Optimization of the active damping system

Noise budget measurement.

**Seismic Attenuation Characterization** We will not directly measure any transmissibility of the suspension. We will rely on other measurements and simulation to estimate the seismic attenuation of the suspension .Simulation will be tuned ad hoc to fit the measurements. This strategy comes after a general decision taken by people involved in the design and specification of the AOS mechanical suspensions.

### 18.2 LAB EQUIPMENT AND SETUP

Existing and new equipment per [T000035-v1](#). Test will require TMS dummy mass and setup rig. Setup will be first made with 'borrowed' quad frame, breadboard control system, with new parts per TMS requirements.

It assumed that the electronics for the sensing and control is already characterized. The following measurements will be done for each single control loop to properly characterize the loop performance:

### 18.3 IDENTIFICATION OF TESTING RESOURCES

#### Mechanical Modes Content Characterization

For this type of measurements we will require the Bruel & Kjaer modal lab system and some custom made system already available at Caltech. Test suspension assembly at CIT room 318 lab using a dummy mass for Telescope and a BSC overhead Optical Table assembly; with a controls system setup. The test will use the requirements [\(T0900265-v1\)](#) to qualify performance. We will follow

### 18.4 TELESCOPE OPTICAL SYSTEM

The off-axis Primary parabolic mirror will be tested by the manufacturer to guarantee that the mirror meets the specification (E0900347-v4). The Secondary parabolic mirror will be tested by the manufacturer to meet specification (E0900349-v4). The optics will also be coated tested by the manufacturer and test results included with each optic.

T1000275-v1

### 18.5 PLANNED TESTS TO VERIFY PERFORMANCE

#### First article Assembly Equipment / Controls / Test Plan

#### First Article Assembly and Testing of the TMS Suspension:

##### Ref 17.3

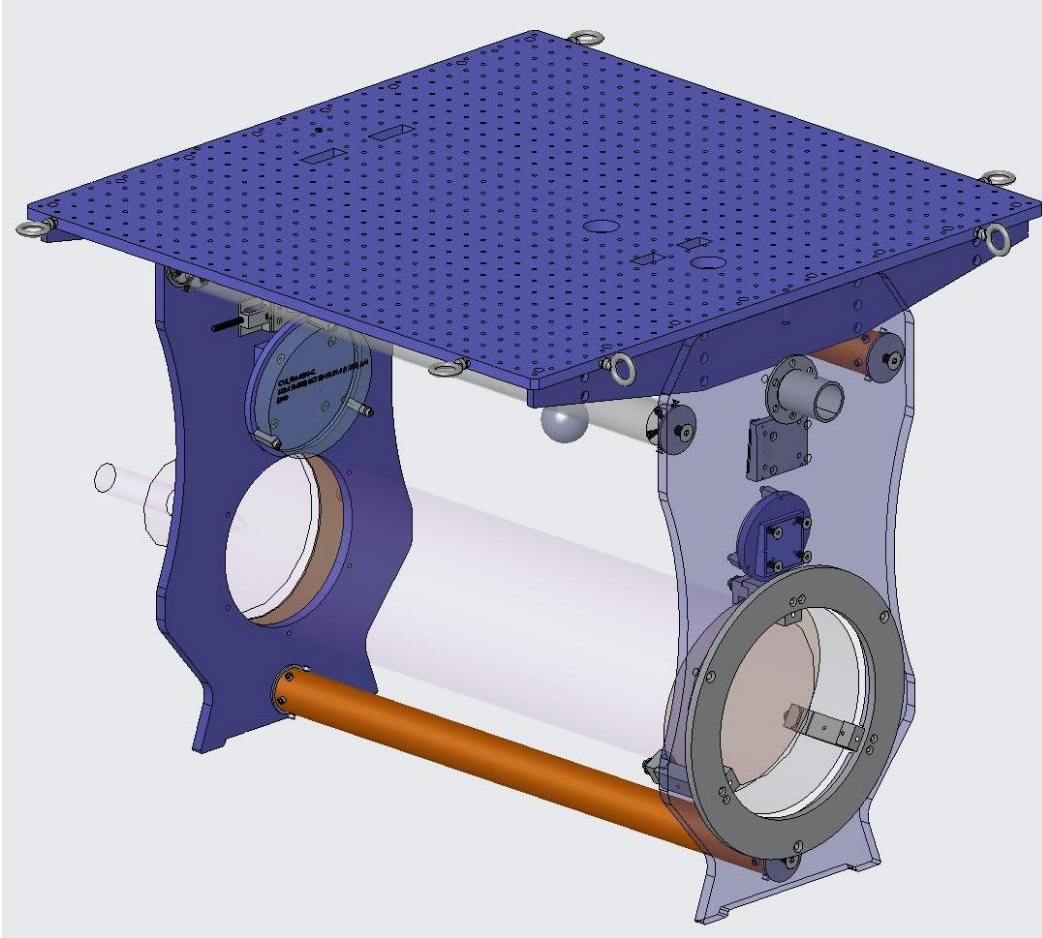
The suspension will be tested at Caltech in room 318, this will test the modified Quad suspensions with a dummy load to see if it meets the TransMon control system requirements. The suspension will be taken apart and shipped to the Hanford Observatory where it will be cleaned and reassembled as a first article.

#### First Article Assembly and Testing of the TMS Telescope:

Testing of the first article TransMon Telescope will be done at Caltech to verify the alignment procedure. We will be using dedicated tooling, to be used later on the full production of six additional units. The telescope will be taken apart and cleaned at CIT, then shipped to the site and reassembled and aligned at the site.

**First Article Assembly and Testing of the TMS Optical Table:**

The Transmon Optical Table will be assembled and aligned at MIT, then tested to verify the Transmon optical performance. The assembly will be taken apart and shipped to the site, where it will be cleaned and re assembled and realigned as a First Article.

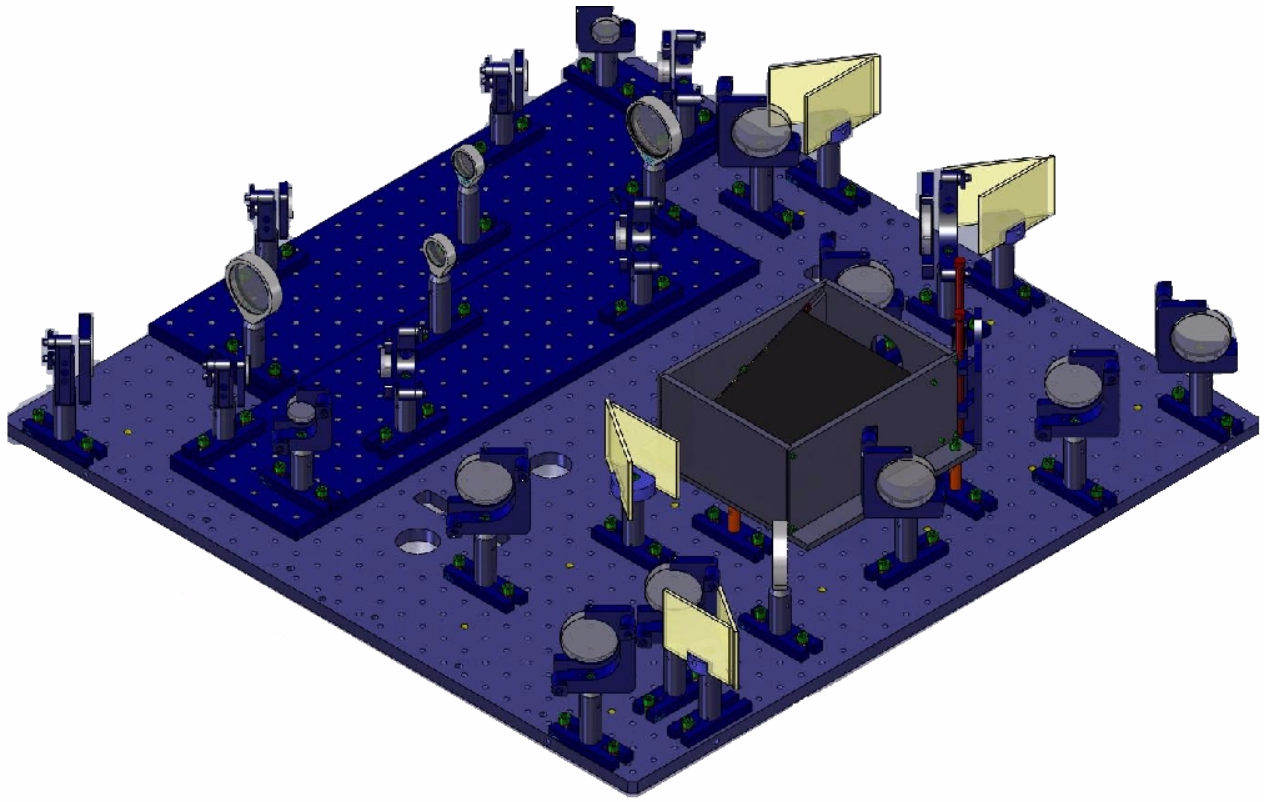


**Figure 36:** TMS Telescope with Optical Table

Ref

Shown at the edges are 4 broken wire safety brackets and on the right edge are shown 2 earth quake stop brackets

First article will be setup and aligned following optical element bench test. The telescope structure will be assembled and optical components installed per assembly D0902083 alignment targets and laser, and autocollimator mounts used per alignment plan T1000275-v1 alignment and focus stability assessed.



**Figure 37:** TMS ISC Optical Table

First article Tests will be done at MIT the setup and test data per

## **19 ENVIRONMENT, SAFETY, AND HEALTH ISSUES**

### **19.1 PERSONNEL AND EQUIPMENT SAFETY HAZARDS**

Document: aLIGO TMS Hazards Analysis

LIGO- T1000311-v1

## **20 QUALITY ASSURANCE PROVISIONS**

This section includes all of the examinations and tests to be performed in order to ascertain the product, material or process to be developed or offered for acceptance conforms to the requirements

### **20.1 GENERAL**

This should outline the general test and inspection philosophy, including all phases of development.

### **20.2 RESPONSIBILITY FOR TESTS**

TBD

### **20.3 CONFIGURATION MANAGEMENT**

Configuration control of specifications and designs shall be in accordance with the LIGO Detector Implementation Plan.

### **20.4 QUALITY CONFORMANCE**

Design and performance requirements identified in this specification and referenced specifications shall be verified by inspection, analysis. Verification method selection shall be specified by individual specifications, and documented by appropriate test and evaluation plans and procedures. Verification of compliance to the requirements of this and subsequent specifications may be accomplished by the following methods or combination of methods:

### **20.5 INSPECTIONS**

Inspection shall be used to determine conformity with requirements that are neither functional nor qualitative; for example, identification marks.

## **21 GENERAL SYSTEM CONSIDERATIONS**

### **21.1 ENVIRONMENTAL CONDITIONS**

Environments that the equipment is expected to experience in shipment, storage, service or use. Subparagraphs should include, as necessary, climate, shock, vibration, noise, etc.

### **21.2 ELECTROMAGNETIC RADIATION**

Electrical equipment associated with the subsystem shall meet the EMI and EMC requirements of VDE 0871 Class A or equivalent. The subsystem shall also comply with the LIGO EMI Control Plan and Procedures (LIGO-E960036).

### **21.3 TRANSPORTABILITY**

All items shall be transportable by commercial carrier without degradation in performance. As necessary, provisions shall be made for measuring and controlling environmental conditions (temperature and accelerations) during transport and handling. Special shipping containers, shipping and handling mechanical restraints, and shock isolation shall be utilized to prevent damage. All containers shall be movable for forklift. All items over 100 lbs. which must be moved into place within LIGO buildings shall have appropriate lifting eyes and mechanical strength to be lifted by cranes.

### **21.4 FINISHES**

Examples: Metal components shall have quality finishes on all surfaces, suitable for vacuum finishes. All sharp edges removed. All materials shall have non-shedding surfaces. Aluminum components used in the vacuum shall not have anodized surfaces. Optical table surface roughness shall be within 32 micro-inch.

### **21.5 SAFETY**

This item shall meet all applicable NSF and other Federal safety regulations, plus those applicable State, Local and LIGO safety requirements. A hazard/risk analysis shall be conducted in accordance with guidelines set forth in the LIGO Project System Safety Management Plan LIGO-M950046-F section 3.3.2.

## **22 TECHNICAL MANUALS AND PROCEDURES**

### **22.1 PROCEDURES**

Procedures shall be provided for, at minimum,

- Initial installation and setup of equipment
- Normal operation of equipment
- Normal and/or preventative maintenance
- Installation of new equipment
- Troubleshooting guide for any anticipated potential malfunctions

### **22.2 MANUALS**

Manuals to be provided, such as operator's manual, or alignment manual at FDR

### **22.3 DOCUMENTATION NUMBERING**

All documents shall be numbered and identified in accordance with the LIGO documentation control numbering system LIGO document TBD

### **22.4 TEST PLANS AND PROCEDURES**

All test plans and procedures shall be developed in accordance with the LIGO Test Plan Guidelines, LIGO document TBD.

### **22.5 LOGISTICS**

The design shall include a list of all recommended spare parts and special test equipment required.

### **22.6 PRECEDENCE**

This section should list the relative importance of requirements (or goals) to be achieved by the design.

### **22.7 QUALIFICATION**

Test and acceptance criteria.



## **23 PREPARATION FOR DELIVERY**

Packaging and marking of equipment for delivery shall be in accordance with the Packaging and Marking procedures specified herein.

### **23.1 PREPARATION**

- Vacuum preparation procedures as outlined in LIGO Vacuum Compatibility, Cleaning Methods and Procedures (LIGO-E960022-00-D) shall be followed for all components intended for use in vacuum. After wrapping vacuum parts as specified in this document, an additional, protective outer wrapping and provisions for lifting shall be provided.
- Electronic components shall be wrapped according to standard procedures for such parts.

### **23.2 PACKAGING**

Procedures for packaging shall ensure cleaning, drying, and preservation methods adequate to prevent deterioration, appropriate protective wrapping, adequate package cushioning, and proper containers. Proper protection shall be provided for shipping loads and environmental stress during transportation, hauling and storage. The shipping crates used for large items should use for guidance military specification MIL-C-104B, Crates, Wood; Lumber and Plywood Sheathed, Nailed and Bolted. Passive shock witness gauges should accompany the crates during all transits.

For all components which are intended for exposure in the vacuum system, the shipping preparation shall include double bagging with Ameristat 1.5<sup>TM</sup> plastic film (heat sealed seams as practical, with the exception of the inner bag, or tied off, or taped with care taken to insure that the tape does not touch the cleaned part). Purge the bag with dry nitrogen before sealing.

### **23.3 MARKING**

Appropriate identification of the product, Per E030350-v2 both on packages and shipping containers; all markings necessary for delivery and for storage, if applicable; all markings required by regulations, statutes, and common carriers; and all markings necessary for safety and safe delivery shall be provided.

Identification of the material shall be maintained through all manufacturing processes. Each component shall be uniquely identified. The identification shall enable the complete history of each component to be maintained (in association with Documentation "travelers"). A record for each component shall indicate all weld repairs and fabrication abnormalities.

For components and parts which are exposed to the vacuum environment, marking the finished materials with marking fluids, die stamps and/or electro-etching is not permitted. A vibratory tool with a minimum tip radius of 0.005" is acceptable for marking on surfaces which are not hidden from view. Engraving and stamping are also permitted.

## **24 NOTES**

This section should contain information of a general or explanatory nature, and no requirements shall appear here. This could be such items as modeling data/results, R&D prototype information, etc.

## Appendix A Quality Conformance Inspections

Appendixes are used to append large data tables or any other items which would normally show up within the body of the specification, but, due to their bulk or content, tend to degrade the usefulness of the specification. Whenever an Appendix is used, it shall be referenced in the body of the specification.

Appendix 1 shall always contain a table which lists the requirements and the method of testing requirements. An example table follows. Additional appendixes can contain other information, as appropriate to the subsystem being specified.

**Table 1 Quality Conformance Inspections**

TBD

Paragraph	Title	I	A	D	S	T
3.2.1	Performance Characteristics					X
3.2.1.1	Controls Performance		X			
3.2.1.2	Timing Performance		X			X

## **25 TMS TEAM**

Team Leader/Mechanical Engineer - Ken Mailand - Caltech

Cognizant Scientist - Sam Waldman - MIT

Telescope Optical Design - Mike Smith

Mechanical Designer - Romero Ignacio - Caltech

Suspensions Modeling - Matt Evans - MIT

Telescope and Optical Table Testing - S. Waldman - MIT

Suspensions Testing - Virginio Sannibale / Bill Kells - Caltech

Suspensions Controls - Jay Heefner - Caltech