



LIGO Laboratory / LIGO Scientific Collaboration

LIGO-T1000044-v2

Advanced LIGO

2 February 2010

aLIGO I&Q RF Demodulator Design

Rich Abbott, Peter Fritschel

Distribution of this document:
LIGO Scientific Collaboration

This is an internal working note
of the LIGO Laboratory.

California Institute of Technology
LIGO Project – MS 18-34
1200 E. California Blvd.
Pasadena, CA 91125
Phone (626) 395-2129
Fax (626) 304-9834
E-mail: info@ligo.caltech.edu

Massachusetts Institute of Technology
LIGO Project – NW22-295
185 Albany St
Cambridge, MA 02139
Phone (617) 253-4824
Fax (617) 253-7014
E-mail: info@ligo.mit.edu

LIGO Hanford Observatory
P.O. Box 1970
Richland WA 99352
Phone 509-372-8106
Fax 509-372-8137

LIGO Livingston Observatory
P.O. Box 940
Livingston, LA 70754
Phone 225-686-3100
Fax 225-686-7189

<http://www.ligo.caltech.edu/>

1 Overview

This document describes the I&Q RF demodulator design for Advanced LIGO. These are designed for use in the ISC (Interferometer Sensing and Control) subsystem, but can also be used anywhere RF demodulation is required. A single demodulator design will be used for both length and alignment sensing photodetectors (LSC RF and WFS detectors in LIGO parlance). Nominally four such demodulator cells will be packaged in one chassis, so that it can service four LSC RF photodetectors or a single four-channel WFS.

2 Block diagram

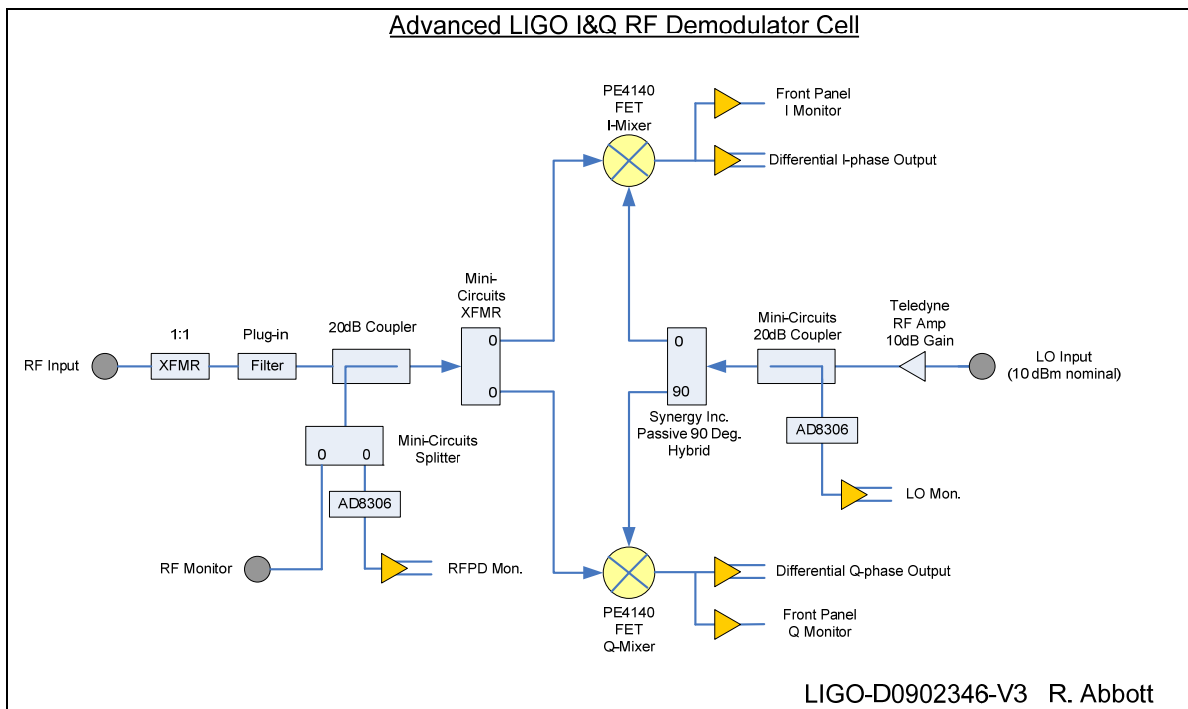

Figure 1 I&Q Demodulator Block Diagram

3 Circuit description

As shown in figure 1 and 2, an RF input, typically from a RF photodetector or RF wavefront sensor, is split into two equal, in-phase signals. The two signals are heterodyned to DC by two mixers. Each mixer is driven by a local oscillator (LO); the phase of one LO is in quadrature to the phase of the other LO. The result is that two separate orthogonal phase audio intermediate frequency (IF) signals are created, effectively splitting the original RF signal into an in-phase and quadrature-phase component.

An elegant aspect to this version of an I&Q demodulator is the particular topology of the RF mixers per a design by Paul Schwinberg of LHO. Each mixer used in the aLIGO I&Q demodulator is constructed using four high linearity FETs in a single package. The FETs in and of themselves

offer an improvement in the large signal performance of the demodulator. By operating the commutating portion of the mixer (the FETs) at close to ground potential, an additional improvement in overall demodulation linearity can be obtained.

Attention was given to providing sensitive and reliable RF signal level monitors as shown in figure 4. A parametric plot of RF detection linearity at different frequencies is shown in figure 5. The absence of reliable RF level monitors in the initial LIGO demodulator frequently resulted in lengthy troubleshooting exercises. Sufficient amplification exists on the board to ensure excellent noise immunity for the detected audio signals. Per figure 3, all audio signals that leave the demodulator board are differentially transmitted for additional noise immunity. The RF input from the photodetectors is ungrounded at DC to avoid introducing ground loops at audio frequencies. An integral low noise RF amplifier is used to boost the LO signal by 10dB to the nominal 20dBm. The demodulator still performs well at considerably lower LO drive levels, and it is anticipated that the wave front sensor application will use a four way passive power splitter to provide the four LO signals at a 6dB reduction in LO power. Monitors are provided on the front panel for the incident RF and the demodulated I and Q audio signals.

The basic demodulator component values can be tailored for higher audio frequency bandwidths as needed by the common mode servo, and the mode cleaner servo. Provisions are made for plug-in RF filters, user configurable RF grounding, and optional LO amplifier bypass are included for flexibility. In general, the boards are a bit difficult to build by hand due to the tiny components. Mass production is best achieved by using machine assembly techniques.

4 Specifications

Operating frequency range	9 - 100 MHz
Nominal LO input level	+10 dBm
LO RF Amplifier Gain	10dB nominal
Mixer conversion loss	-4 ±0.5 dB
Conversion gain from RF input to Q output	22 ± 1 dB
RF input impedance	50 ohm nominal
LO input impedance	50 ohm nominal
RF input referred noise @100 Hz offset	9-54 MHz: 4 nV/√Hz typ; 5 nV/√Hz max 100 MHz: 7 nV/√Hz typ; 8 nV/√Hz max
I/Q differential output noise @ 100 Hz	9-54 MHz: 200 nV/√Hz typ; 250 nV/√Hz max 100 MHz: 350 nV/√Hz typ; 400 nV/√Hz max
I/Q differential output bandwidth	34kHz standard, user configurable to > 1MHz
Amplitude imbalance of I & Q outputs	< 50 mdB

Phase imbalance of I & Q outputs (vs. 90 deg.)	< 5 degrees
RF Level detector output (Diff. Out)	120mV/dB, 90 dB dynamic range, -45dBm min.
LO Level detector output (Diff. Out)	120mV/dB, 90 dB dynamic range, -60dBm min.
Input power	+ 15 V, 0.23 amps +/-10% - 15 V, 0.09 amps +/-10%

Table 1 Specifications for the I/Q demodulator board.

5 Circuits

Figure 2 Overall Demodulator Circuitry

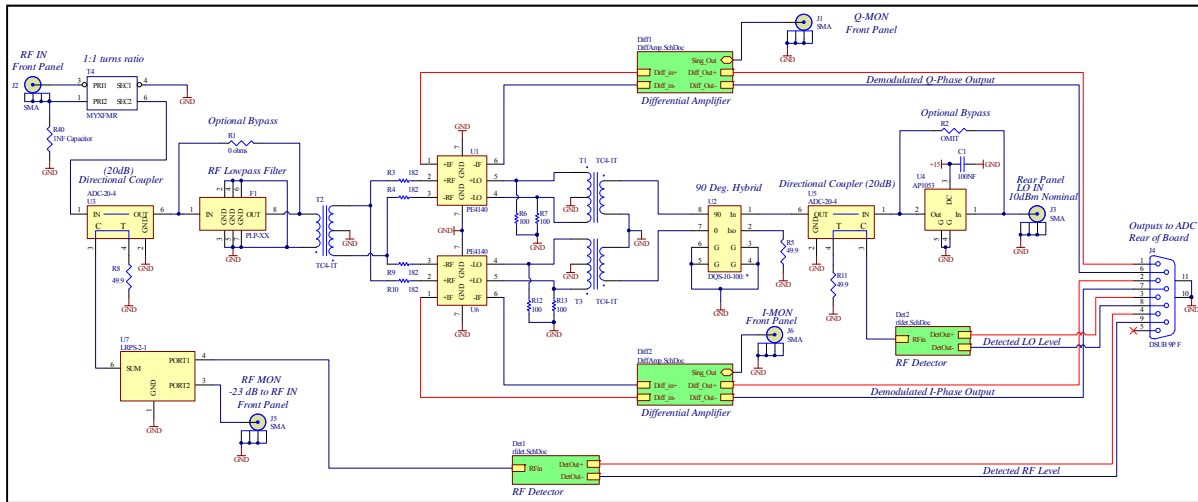

Figure 3 IF Output Amplifier

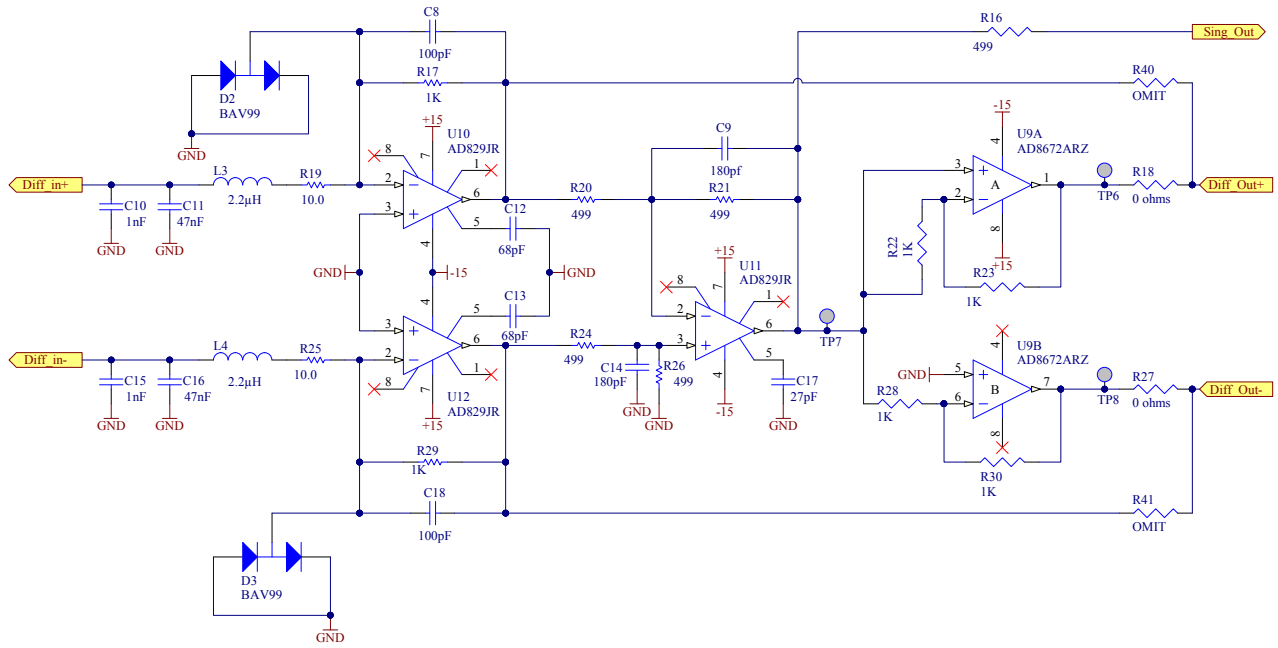

Figure 4 Log RF Detector Circuit

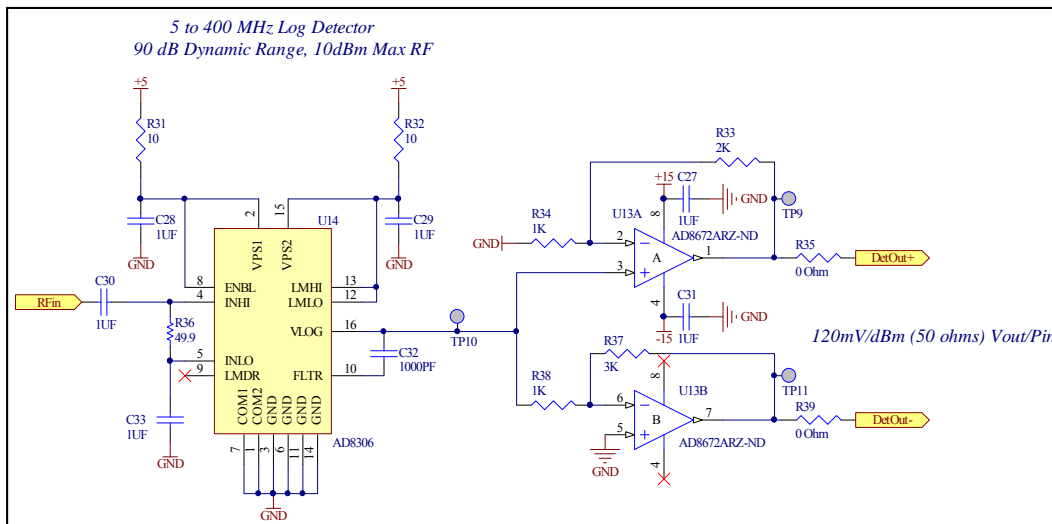
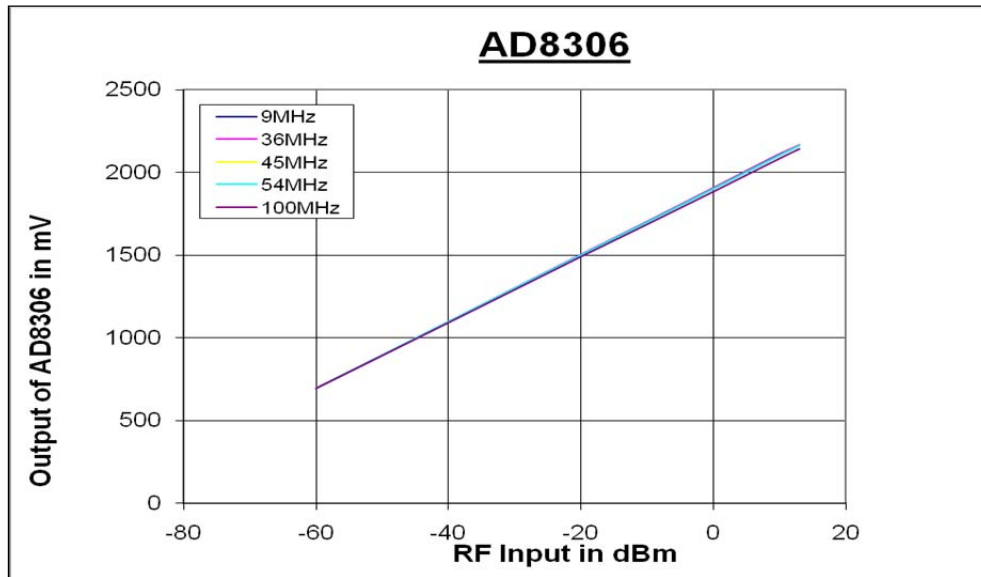

Figure 5 Measured RF Input Level Detector Response



6 Packaging

A 1U standard LIGO chassis will be used to house 4 separate I/Q demodulator boards. A regulator board will be used to regulate the raw +/- 18 VDC power supply to +/- 15 VDC as required by the demodulator circuits. Up to four different LO frequencies can be used per demodulator chassis.

Figure 6 Demodulator Chassis

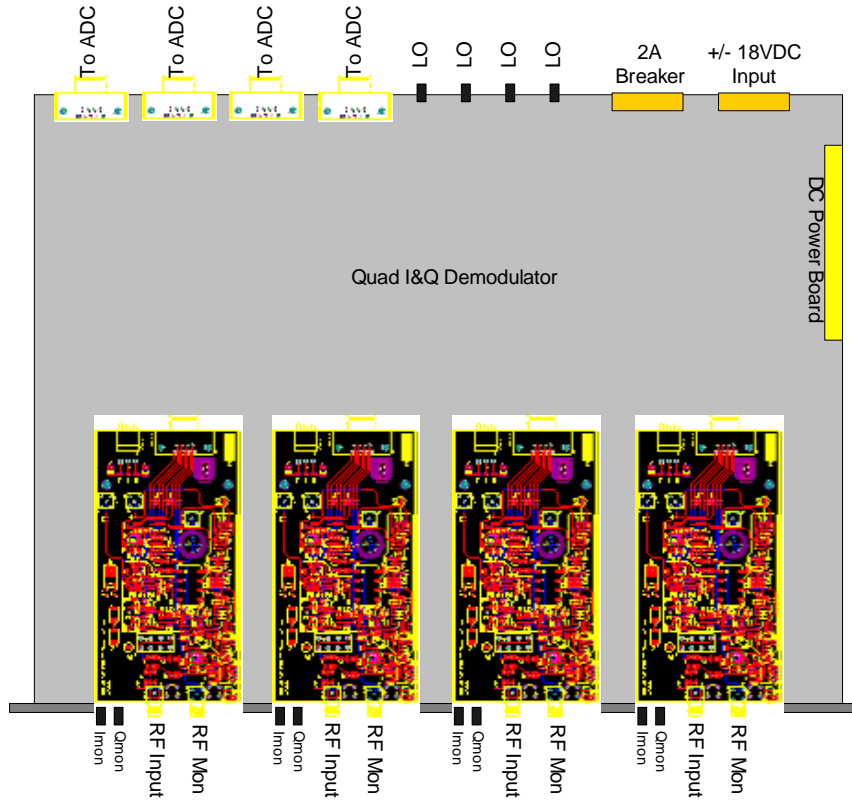

Figure 7 Front Panel

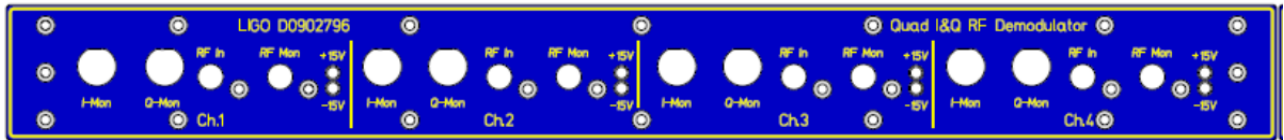

Figure 8 Rear Panel



7 Test Data for S1000094

Figure 9 LO Input Impedance

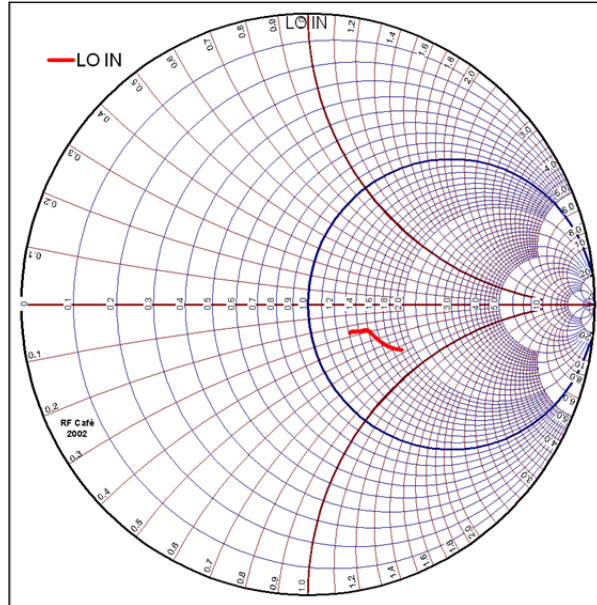

Figure 10 RF Input Impedance

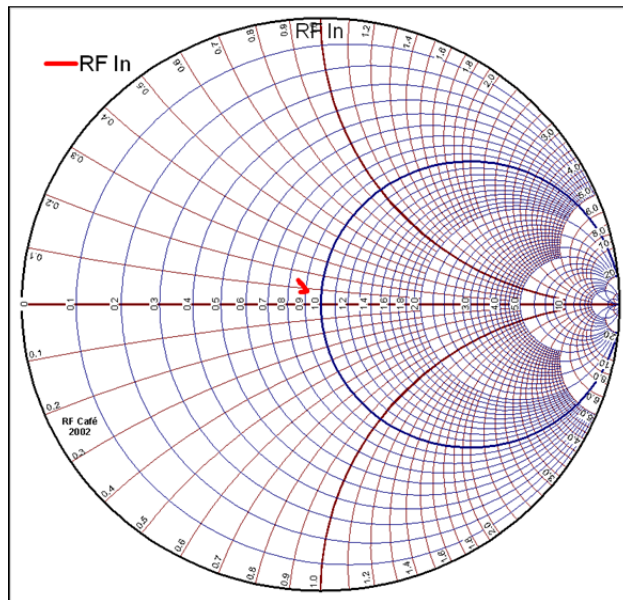

Table 1 RF Monitor Coupling Loss

Frequency (MHz)	Loss RFin to RFmon (dB)
9	22.7
36	23
45	23
54	23.1
100	23.1

Table 2 Demodulator Conversion Gain

	dBm RF input	Vp-p Qout, diff	RF input Vp-p	RF input Ap-p	RF current in/4 *	Current R19 Ap-p	Conversion Loss (dB) of mixer	Conversion from RFin to Qout(diff) (dB)
9MHz	-1.03	27.81	0.562	1.12E-02	2.81E-03	1.74E-03	-4.2	33.9
36MHz	-1	27.94	0.564	1.13E-02	2.82E-03	1.75E-03	-4.2	33.9
45MHz	-1.33	27.63	0.543	1.09E-02	2.71E-03	1.73E-03	-3.9	34.1
54MHz	-0.97	27.53	0.566	1.13E-02	2.83E-03	1.72E-03	-4.3	33.7
100MHz	-1.3	26.87	0.545	1.09E-02	2.72E-03	1.68E-03	-4.2	33.9

Figure 11

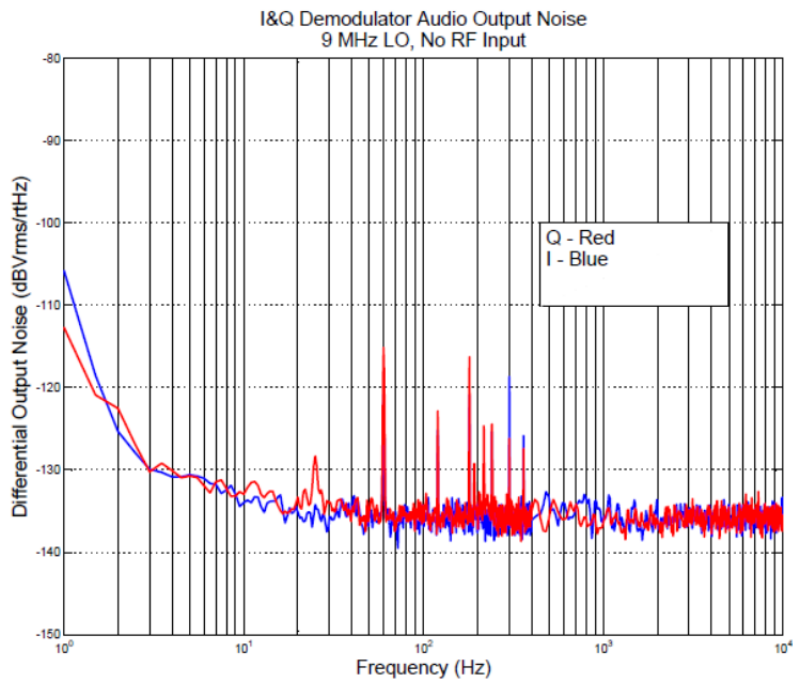

Table 3

Frequency (MHz)	100 Hz I Noise Floor differentially at J4 (dBVrms/rtHz)	Translated to RFin (dBVrms/rtHz)	RFin Vrms/rtHz	RFin W/Hz, 50 ohms	RFin dBm/Hz 50 ohms
9	-135	-168.9	3.59E-09	2.58E-19	-155.9
36	-134	-167.9	4.03E-09	3.24E-19	-154.9
45	-133	-167.1	4.40E-09	3.87E-19	-154.1
54	-133	-166.7	4.60E-09	4.23E-19	-153.7
100	-129	-162.9	7.19E-09	1.03E-18	-149.9

Table 4 I&Q Demodulated Amplitude and Phase Balance

Frequency (MHz) RF=LO+10kHz	Amplitude Balance 20LOG(I/Q)	Demodulated Phase Balance (Degrees I to Q @ 10kHz)
9	-28 mdB	88.76
36	7 mdB	92.3
45	-7 mdB	93
54	-17.5 mdB	93.1
100	-7 mdB	91.7

Table 5 Detected RF Level for LO and RF Inputs (VDC at Differential Out)

RF Input	9MHz RF	9MHz LO	50MHz RF	50MHz LO	100MHz RF	100MHz LO
No RF	2.007 V	1.990 V	2.003 V	1.988 V	2.004 V	1.990 V
-50 dBm	2.722 V	4.34 V	2.667 V	4.31 V	2.646 V	4.31 V
-25dBm	5.65 V	7.38 V	5.64 V	7.34 V	5.61 V	7.30 V
0dBm	8.68 V	10.40 V	8.65 V	10.36 V	8.60 V	10.29 V
10dBm	9.88 V	11.60 V	9.85 V	11.55 V	9.79 V	11.46 V

Table 6 shows the results from an injection of 1% amplitude modulation at 44 Hz modulation Frequency on an RF carrier applied to the LO input of the demodulator. Due to finite isolation between the LO input and the RF path, there is a measurable tendency to amplitude demodulate the LO. For an LO with sufficient AM pollution, the output noise of the demodulator would begin to be dominated by LO AM noise. Table 6 shows the allowable limits of AM noise present on the LO to equal the output noise of the demodulator circuit. Confusing at best.

Table 6 LO RFAM Limits

LO Frequency MHz	Equivalent LO RFAM for Iout noise floor	Equivalent LO RFAM for Qout noise floor
9	7.11E-04	1.05E-03
36	1.36E-04	9.15E-05
45	1.12E-04	5.29E-05
54	8.00E-05	5.89E-05
100	7.17E-05	3.87E-04

8 Testing

Each production board will be functionally tested for compliance with the following:

RF Tests

- Power supply current at specified voltage².
- Insertion loss from RF input to RF monitor over a frequency range from 5MHz to 100MHz.
- RF and LO input impedance over a frequency range from 5 MHz to 100 MHz
- LO to RF isolation transfer function from at 10dBm RF drive level from 5 MHz to 100 MHz⁵.
- RF and LO RF detector response at 9, 36, 45, 54 MHz at -20, -10, 0, 10 dBm. Record differential detected voltage.

IF Tests

- Measure conversion loss to the differential and single ended IF outputs as a function of frequency at RF = 0dBm from 5 MHz to 100 MHz
- Measure I&Q balance at differential outputs for 9, 36, 45, 54 MHz, 0dBm.
- Calculate the RF input referred noise (50 ohms on RF input) by knowledge of the conversion loss and the measured audio spectral output noise. Measure at audio frequencies from 1 Hz to 100 kHz (800 point fft, multiple spans). This will also yield the output noise of the audio portion of the circuit.