

- NOTES CONTINUED:
- SCRIBE, ENGRAVE, OR MECHANICALLY STAMP (NO INKS OR DYES) DRAWING PART NUMBER AND REVISION ON NOTED SURFACE FOLLOWED ON THE NEXT LINE BY A THREE DIGIT SERIAL NUMBER. SERIAL NUMBERS START AT 001 FOR THE FIRST ARTICLE AND PROCEED CONSECUTIVELY. USE .07" HIGH CHARACTERS. EXAMPLE: DXXXXX-VV, S/N 001. VIBRATORY TOOL MAY BE USED.
 - APPROXIMATE WEIGHT = X.XXX LB.
 - MACHINE ALL SURFACES TO REMOVE OXIDES AND MILL FINISH. USE OF ABRASIVE REMOVAL TECHNIQUES IS NOT ALLOWED. REFER TO LIGO-E0900364.
 - ALL PARTS SHALL BE MANUFACTURED IN ACCORDANCE WITH LIGO SPECIFICATION E0900364.
 - ALL HELI-COIL HOLES TO BE PREPARED ACCORDING TO EMHART HELI-COIL PRODUCT CATALOG, HC2000, REV 4
 - ALL HELI-COIL INSERTS TO BE INSTALLED BY LIGO PERSONNEL AFTER DELIVERY OF FINISHED PARTS. USE NITRONIC 60 THREADED INSERTS.

- ALL MATERIAL IS TO BE VIRGIN MATERIAL (i.e. NO WELD REPAIRS, PLUGS OR RECYCLED MATERIAL). NO REPAIRS SHALL BE MADE UNLESS APPROVED IN ADVANCE, AND IN WRITING, BY LIGO LABORATORY. REFER TO LIGO-E0900364.
- SURFACE FINISH TO BE AS-PROCESSED FROM MILL/SUPPLIER, FREE FROM SCRATCHES OR GOUGES.
- PART WILL BE PORCELAIN COATED PER LIGO SPECIFICATION E1000083 AFTER FABRICATION. THE INDICATED HOLES WILL BE MASKED PRIOR TO PORCELAIN COATING TO APPROXIMATELY 2.5-3X HOLE DIAMETER CENTERED ON BOTH SIDES OF THE HOLE.
- DIMENSIONS APPLY BEFORE PORCELAIN COATING UNLESS SPECIFIED.
- BEND RADIUS: UNLESS OTHERWISE NOTED, THE BEND RADIUS SHOULD BE THE MINIMUM REQUIRED TO FORM WITHOUT CRACKING OR REQUIRING ADDITIONAL WORK WHEN FORMING. IN PARTICULAR IF SHEET METAL IS TO BE PORCELAIN COATED, THE BEND RADIUS SHALL BE A MINIMUM OF .12" OUTSIDE RADIUS OF BEND UNLESS OTHERWISE NOTED.

NOTES 9, 10, 13 and 14 DO NOT APPLY TO THIS PART

CONNECTOR J1

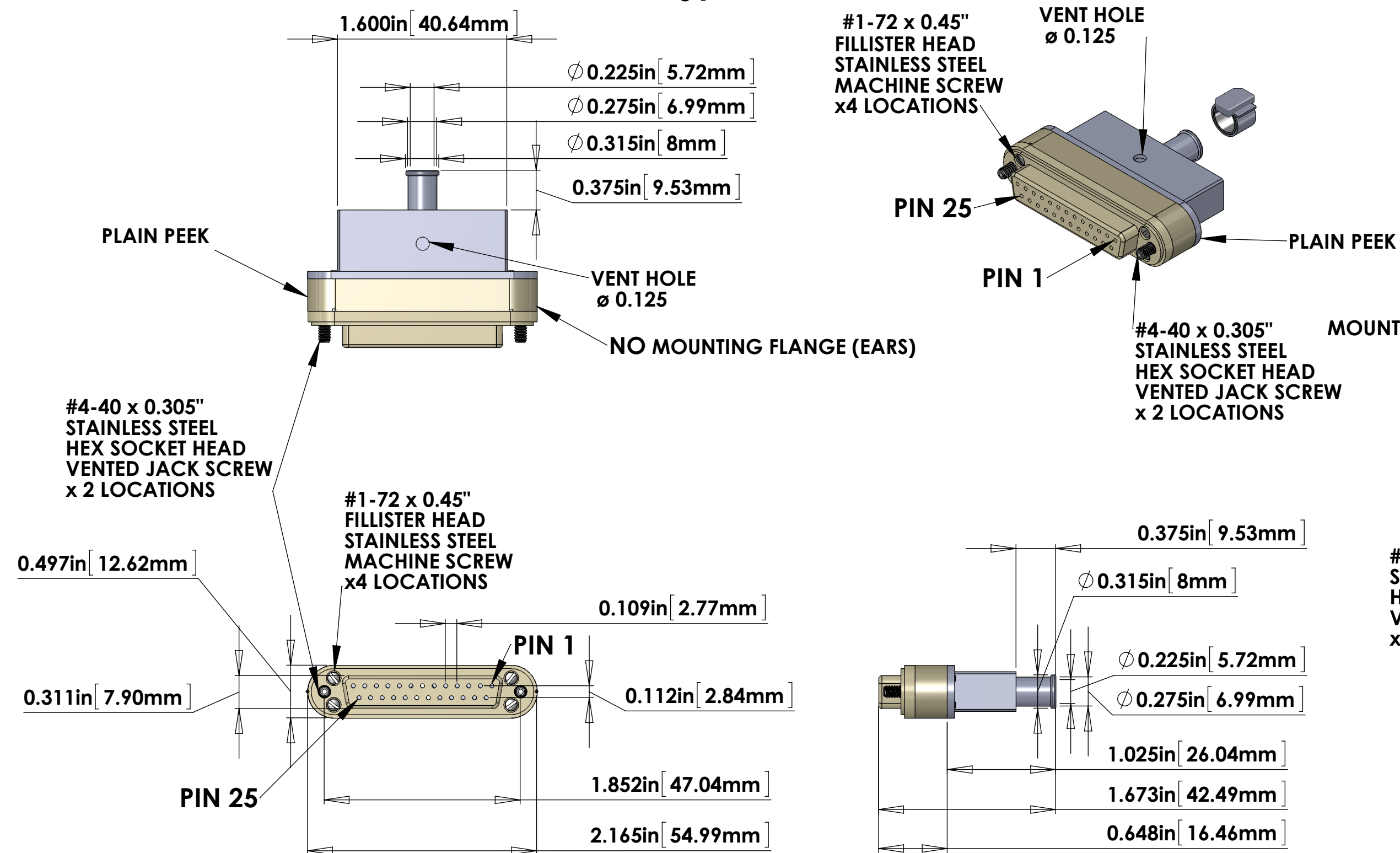

CONNECTOR J2

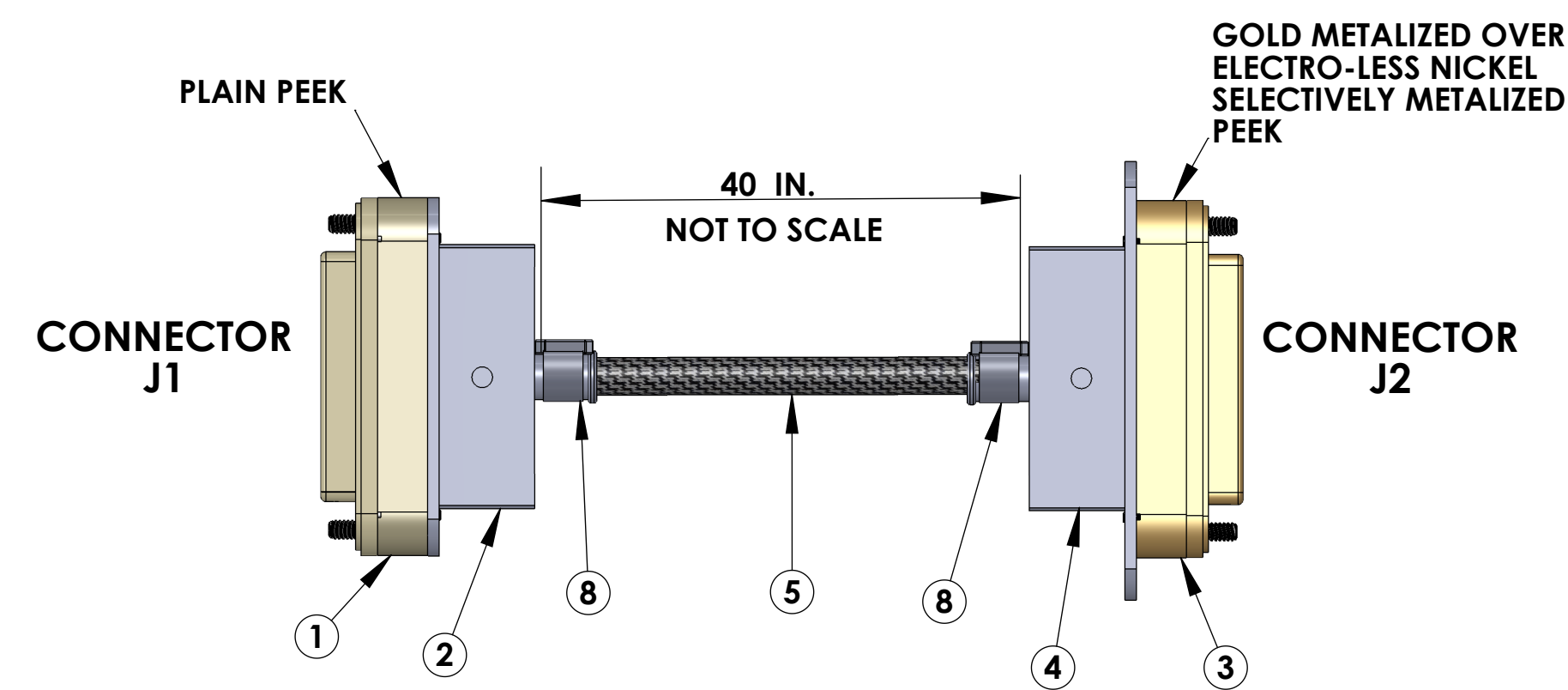
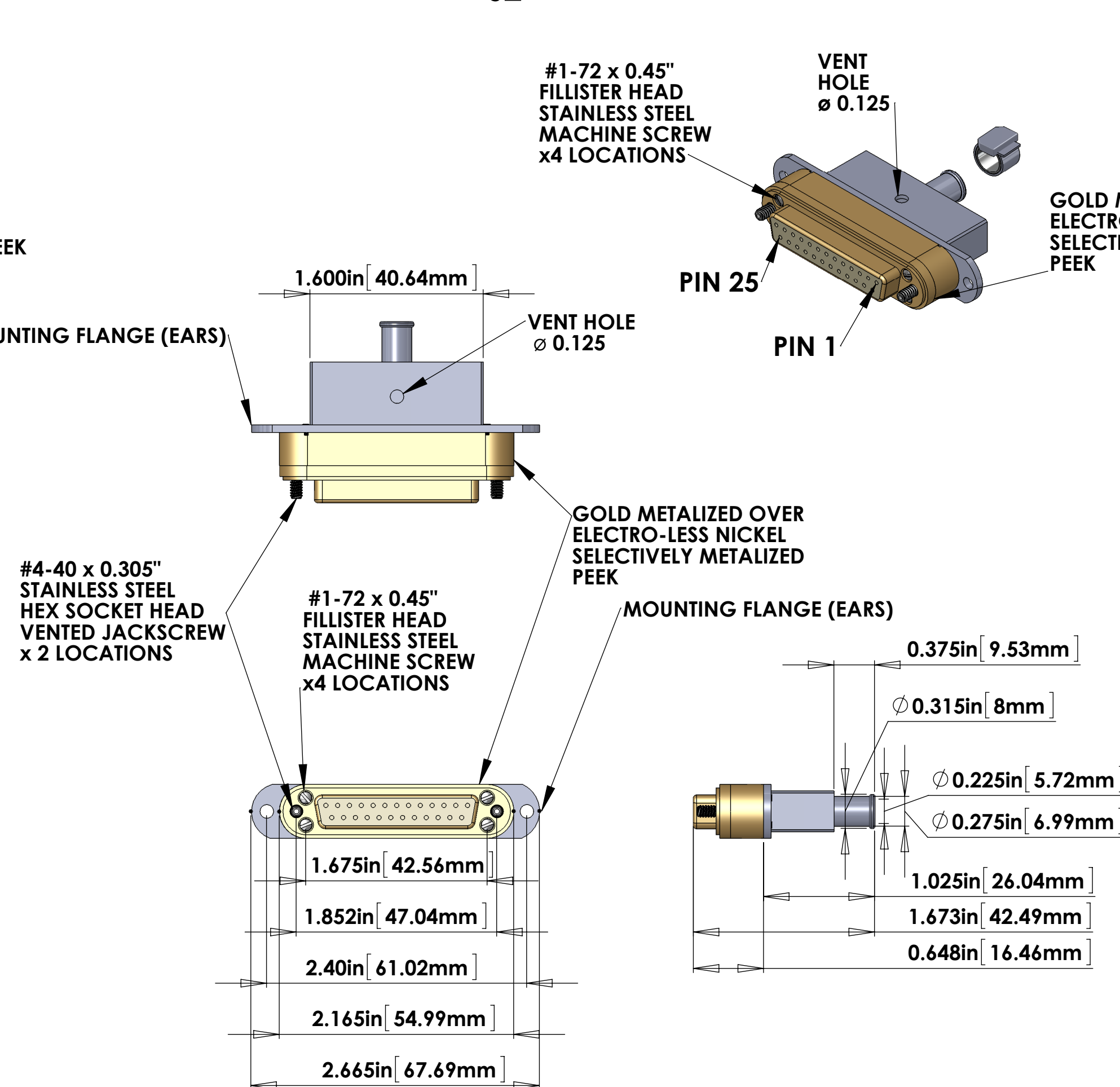

V25A-40 CABLE ASSEMBLY CIRCUIT SUMMARY V-DB25 F/S1-40-DB25 F/S1

CABLE NAME	COND.- WIRE ID	TWISTED PAIR	LENGTH *	FROM	TO
V25A-40	25 COND. CABLE	(12 TOTAL)	40 in.	Conn. J1	Conn. J2
	W1	SHIELD	40 in	PIN 1, SHELL	PIN 1, SHELL
	W2	TP-1	40 in	PIN 2	PIN 2
	W14		40 in	PIN 14	PIN 14
	W3	TP-2	40 in	PIN 3	PIN 3
	W15		40 in	PIN 15	PIN 15
	W4	TP-3	40 in	PIN 4	PIN 4
	W16		40 in	PIN 16	PIN 16
	W5	TP-4	40 in	PIN 5	PIN 5
	W17		40 in	PIN 17	PIN 17
	W6	TP-5	40 in	PIN 6	PIN 6
	W18		40 in	PIN 18	PIN 18
	W7	TP-6	40 in	PIN 7	PIN 7
	W19		40 in	PIN 19	PIN 19
	W8	TP-7	40 in	PIN 8	PIN 8
	W20		40 in	PIN 20	PIN 20
	W9	TP-8	40 in	PIN 9	PIN 9
	W21		40 in	PIN 21	PIN 21
	W10	TP-9	40 in	PIN 10	PIN 10
	W22		40 in	PIN 22	PIN 22
	W11	TP-10	40 in	PIN 11	PIN 11
	W23		40 in	PIN 23	PIN 23
	W12	TP-11	40 in	PIN 12	PIN 12
	W24		40 in	PIN 24	PIN 24
	W13	TP-12	40 in	PIN 13	PIN 13
	W25		40 in	PIN 25	PIN 25

* THE LENGTH SHOWN IN THIS LIST IS THE LENGTH OF THE CABLE BETWEEN THE TWO CONNECTORS. ADD ADDITIONAL LENGTH AS NECESSARY FOR THE INTERNAL WIRING OF THE CONNECTORS AND STRIP LENGTH.

ITEM NO.	PART NUMBER	DESCRIPTION	QTY.	LENGTH
1	TICOR # (TS0148-25C020BS1-225) OR EQUIVALENT	DB25 FEMALE CONNECTOR (J1) FOR UHV (PEEK)	1	
2	TICOR # (TS0148-25C020BS1-225) OR EQUIVALENT	DB25 CONNECTOR BACKSHELL (NO EARS) FOR UHV (STAINLESS)	1	
3	TICOR # (TS0148-25CG20BS1-225F) OR EQUIVALENT	DB25 FEMALE CONNECTOR (J2) FOR UHV (GOLD METALIZED PEEK)	1	
4	TICOR # (TS0148-25CG20BS1-225F) OR EQUIVALENT	DB25 CONNECTOR BACKSHELL (WITH EARS) FOR UHV (STAINLESS)	1	
5	C1	25 COND. (12 TW PAIR + 1 WIRE + SHIELD) CABLE WITH 6 COPPER BRAID (SHIELD) AND 7 PEEK OVERBRAID	1	40in *
6	CONTINENTAL PART #24x3x40BC	COPPER BRAID - CONTINENTAL CORDAGE PART #24x3x40BC	1	40in *
7	#6759	PEEK BRAID - PART #6759 MANUFACTURED WITH ZEUS 0.016" BLACK PEEK DRAWN MONOFILAMENT	1	40in *
8	GLENAIR # 600-052 or BAND-IT # A10086	GLENAIR # 600-052 STANDARD BRAID CLAMP or BAND-IT PART # A10086 (0.240" WIDE) ("BAG OF 100" # A10089)	2	

* NOTE: USE WHATEVER LENGTH IS NECESSARY FOR THE INTERNAL WIRING OF THE CONNECTORS AND STRIP LENGTH TO ACHIEVE THE CORRECT OVERALL LENGTHS.

NOTES: (UNLESS OTHERWISE SPECIFIED)

- MATERIAL:
 - J1 CONNECTOR SHELL - PEEK VICTREX 450GL30.
 - J2 CONNECTOR SHELL - GOLD OVER ELECTRO-LESS NICKEL SELECTIVELY METALIZED PEEK VICTREX 450GL30.
 - BACKSHELLS - STAINLESS STEEL WITH VENT HOLE.
 - CONTACTS - BERYLLIUM COPPER ALLOY C17300 0.000050 MIN. GOLD OVER NICKEL.
 - HARDWARE: STAINLESS STEEL, PASSIVATED.
 - PEEK BRAID - PEEK VICTREX GRADE TDS-450CA30 CARBON LOADED - SUPPLIED BY LIGO.

- CABLE 25 COND. 28 AWG, (40 STRD 44 AWG) WITH 2 LAYERS OF KAPTON TAPE. 12 TWISTED PAIRS (4 TO 5 TWISTS PER INCH) + 1 WIRE. OVERALL 40AWG COPPER BRAID 50% COVERAGE - SUPPLIED BY LIGO. OVERALL PEEK BRAID MIN. 50% COVERAGE. OVERALL CABLE O.D. WILL BE 0.240 IN.

- CONNECTORS WILL BE SUPPLIED WITH HARDWARE. SCREWS SHOULD BE THE PROPER LENGTH FOR MATING.

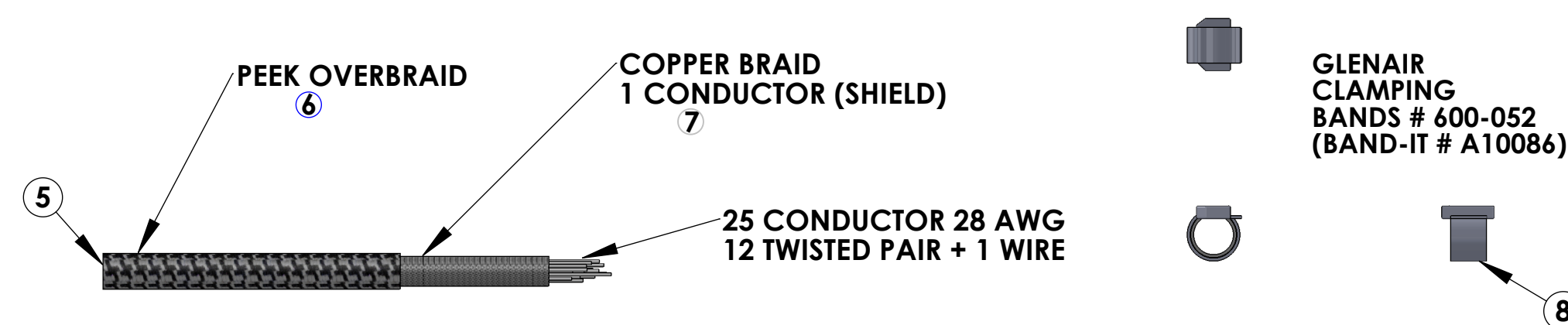

NOTES AND TOLERANCES: (UNLESS OTHERWISE SPECIFIED)	
DIMENSIONS ARE IN	1. INTERPRET DRAWING PER ASME Y14.5-1994.
TOLERANCES:	2. REMOVE ALL SHARP EDGES, .005-.015. FOR MACHINED PARTS. ROUND ALL EDGES APPROXIMATELY R.02 FOR SHEET METAL PARTS.
ANGULAR ± °	3. DO NOT SCALE FROM DRAWING.
	4. ALL MACHINING FLUIDS MUST BE FULLY SYNTHETIC, FULLY WATER SOLUBLE AND FREE OF SULFUR, SILICONE, AND CHLORINE.
MATERIAL	Material <not specified>
FINISH	μinch

LIGO CALIFORNIA INSTITUTE OF TECHNOLOGY MASSACHUSETTS INSTITUTE OF TECHNOLOGY		PART NAME	
SYSTEM	SEI, ISC	CUSTOM CABLE SPECIFICATION V25A-40	
DESIGNER	B. ABBOTT	MAY/01/2012	SIZE
DRAFTER	E. BROWN	MAY/01/2012	DWG. NO.
CHECKER			D
APPROVAL			D1000220
		SCALE: 1:1	PROJECTION:
			SHEET 1 OF 1