

REV	DATE	CHKD	APPROVAL	DESCRIPTION
A	7/27/2007		A. STEIN	INITIAL RELEASE

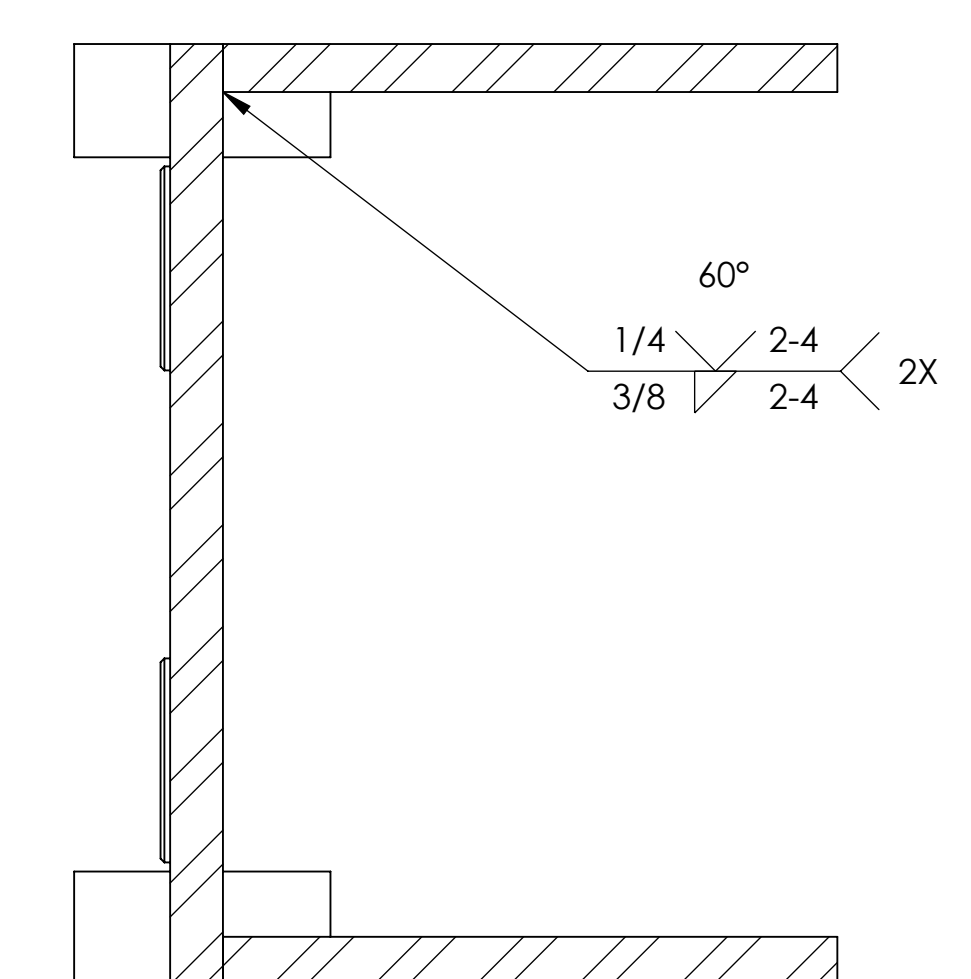
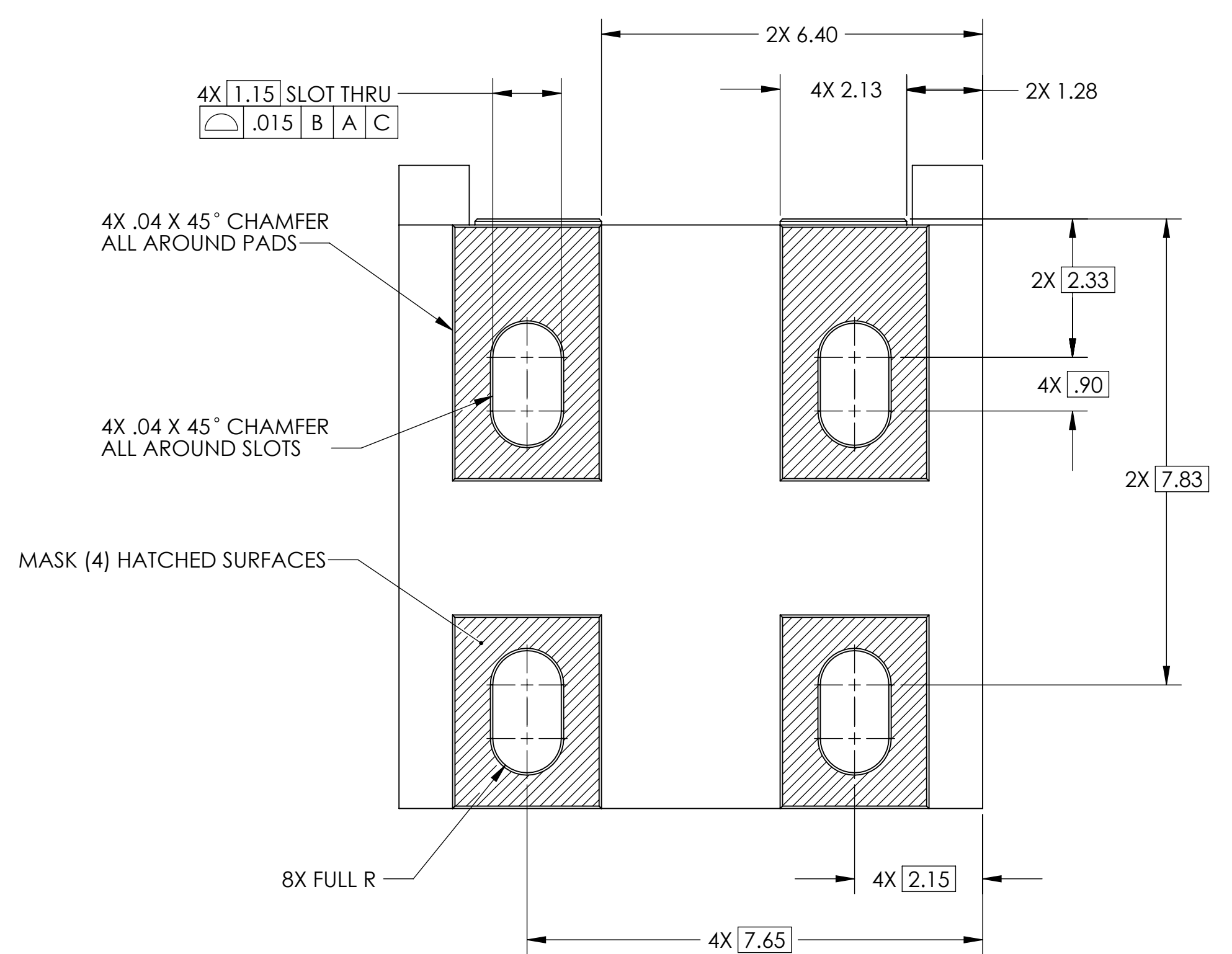
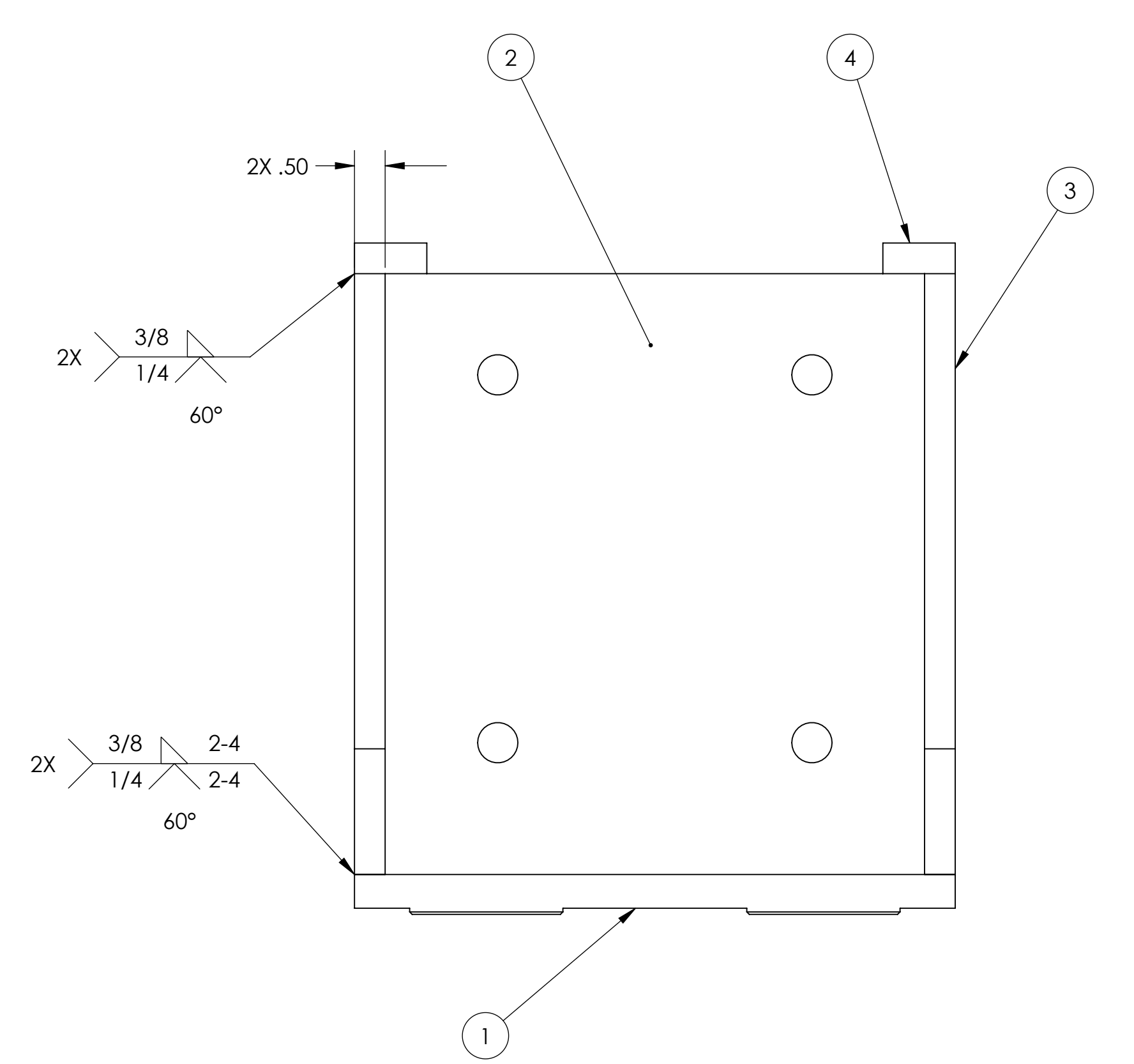
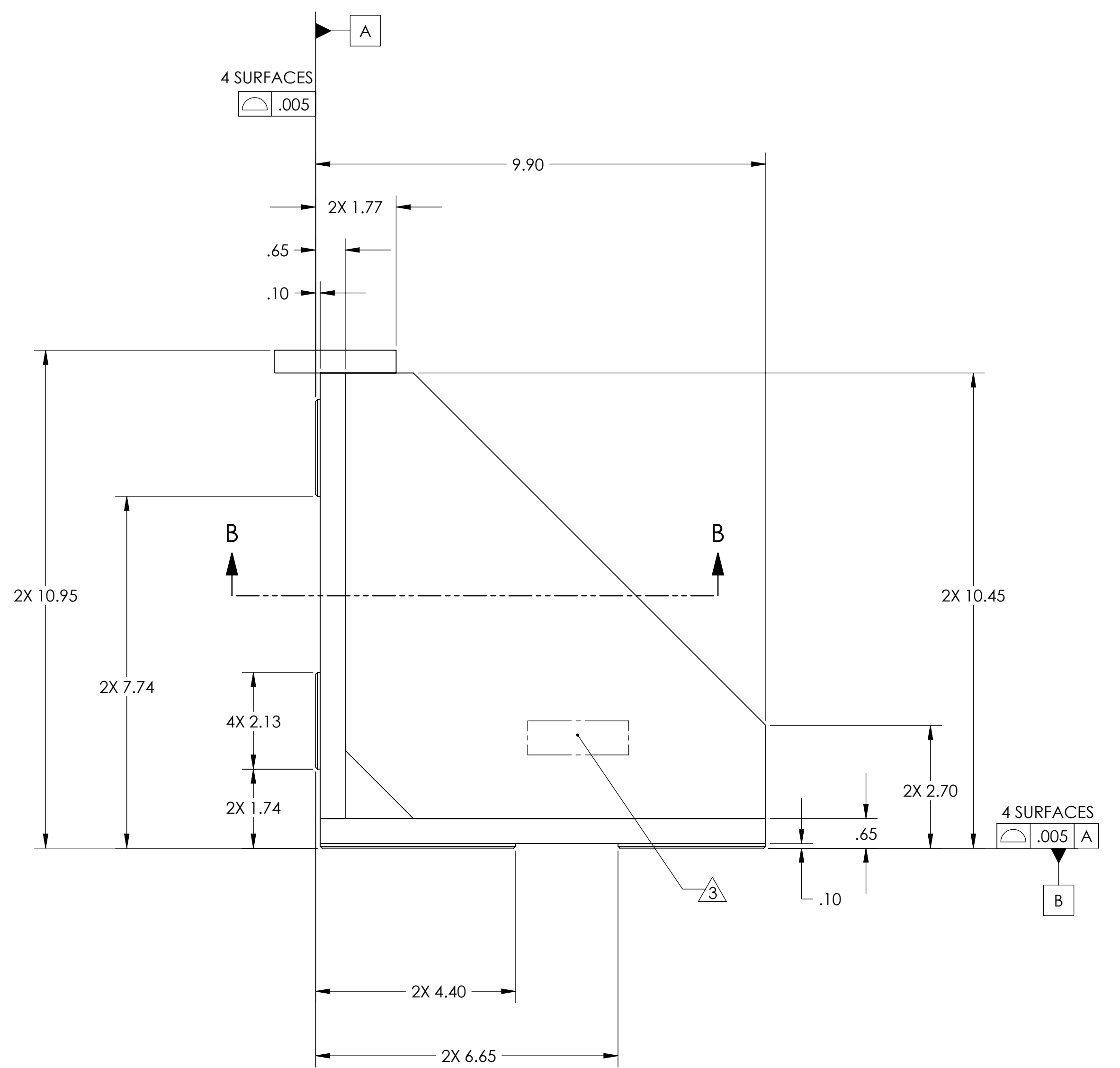
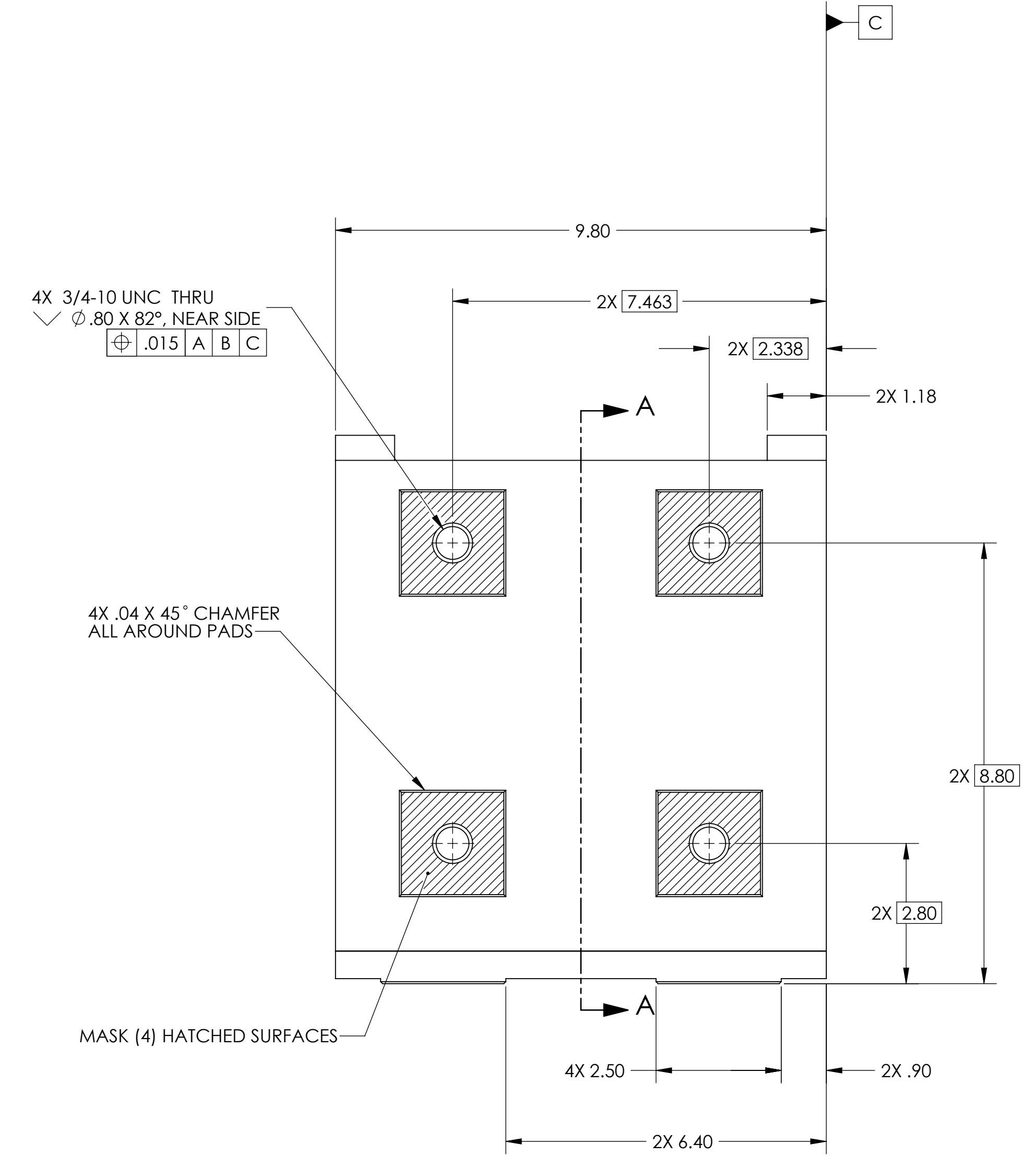
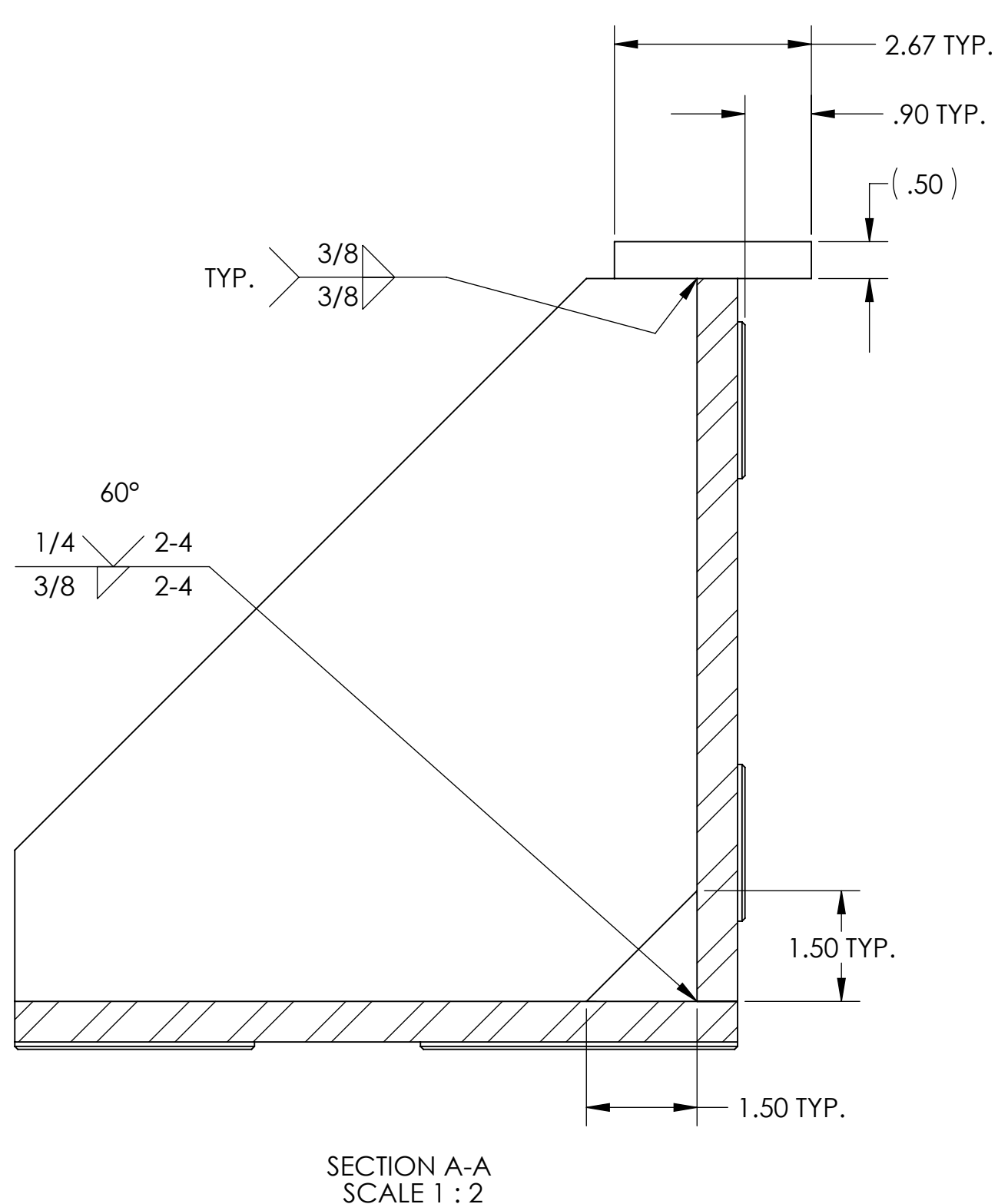
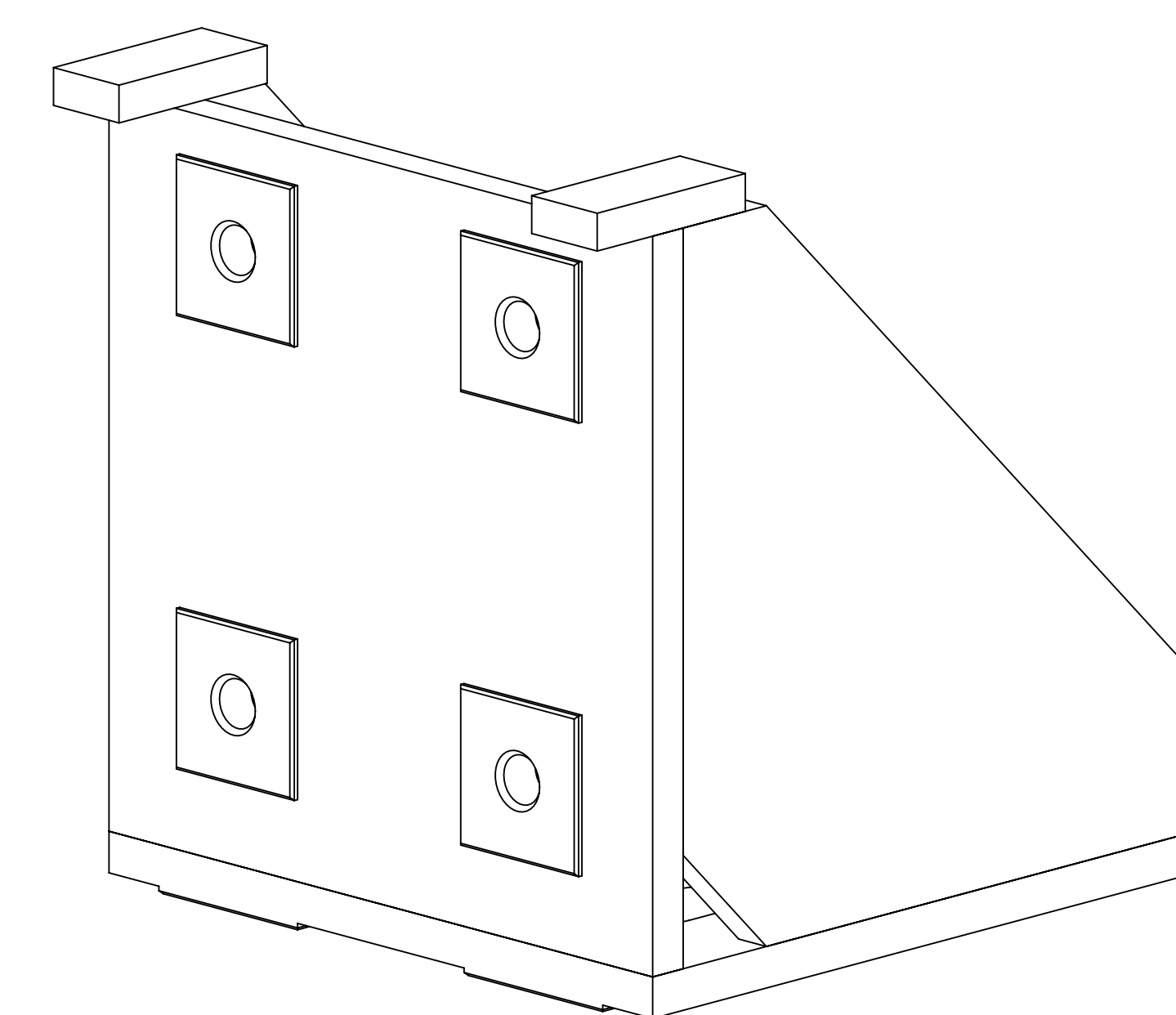

- NOTES:
1. THOROUGHLY CLEAN PART TO REMOVE ALL OIL, GREASE, DIRT, AND CHIPS.
  2. ALL MACHINING FLUIDS MUST BE WATER SOLUBLE AND FREE OF SULFUR, CHLORINE, AND SILICONE, SUCH AS CINCINNATI MILACRON CIMTECH 410.
  3. WHERE INDICATED, MECHANICALLY SCRIBE, STAMP, OR ENGRAVE (VIBRATORY ACCEPTABLE) THE FOLLOWING INFORMATION AS SHOWN BELOW: PART NUMBER-REVISION, USE 0.12" TALL CHARACTERS UNLESS PART SIZE DICTATES SMALLER.  
D070277-A
  4. PAINT SMOOTH WHITE, SHERWIN WILLIAMS POLANE T-PLUS POLYURETHANE ENAMEL. MASK ALL HOLES AND AREAS MARKED ON PRINT.
  5. PRIME WITH SHERWIN WILLIAMS INDUSTRIAL WASH PRIMER P60G2.

ITEM NO.	Default/ QTY.	DESCRIPTION	Material
1	1	BASE, BOTTOM PLATE	A36 STEEL
2	1	BASE, FRONT PLATE	A36 STEEL
3	2	BASE, GUSSET	A36 STEEL
4	2	BASE, TOP PLATE	A36 STEEL

UNLESS OTHERWISE SPECIFIED  
DIMENSIONS ARE IN INCHES

SCALE: 1:2

DATE: 7/27/2007

DRAWN: E

SEE BOM

SEE NOTES

NAME: TEST STAND BASE WELDMENT

DATE: 7/27/2007

REV: A

SCALE: 1:2

SHEET 1 OF 1