

D0902541\_Diaphragm-Vert\_Gs-13-BSC\_ISI, PART PDM REV: X-004, DRAWING PDM REV: X-002

**NOTES CONTINUED:**  
 5. SCRIBE, ENGRAVE, OR MECHANICALLY STAMP (NO INKS OR DYES) DRAWING PART NUMBER, REVISION (AND VARIANT OR "TYPE" IF APPLICABLE) ON NOTED SURFACE OF PART FOLLOWED ON THE NEXT LINE WITH A THREE DIGIT SERIAL NUMBER. SERIAL NUMBERS START AT 001 FOR THE FIRST ARTICLE AND PROCEED CONSECUTIVELY. USE MINIMUM 0.12" HIGH CHARACTERS, UNLESS THE SIZE OF THE PART DICTATES SMALLER CHARACTERS. A VIBRATORY TOOL MAY BE USED.  
 EXAMPLE: DXXXXXX-VY, TYPE-XX, S/N XXX  
 6. ALL PARTS SHALL BE MANUFACTURED IN ACCORDANCE WITH LIGO SPECIFICATION E0900364.  
 7. APPROXIMATE WEIGHT: 2.6LB.  
 8. MACHINE ALL SURFACES TO REMOVE OXIDES AND MILL FINISH.  
 9. ABRASIVE REMOVAL TECHNIQUES ARE NOT ACCEPTABLE.

REV.	DATE	DCN #	DRAWING TREE #
v1	5 FEB 2010	E0900444	E1000025
v2	21 MAY 2010	E1000178	E1000025

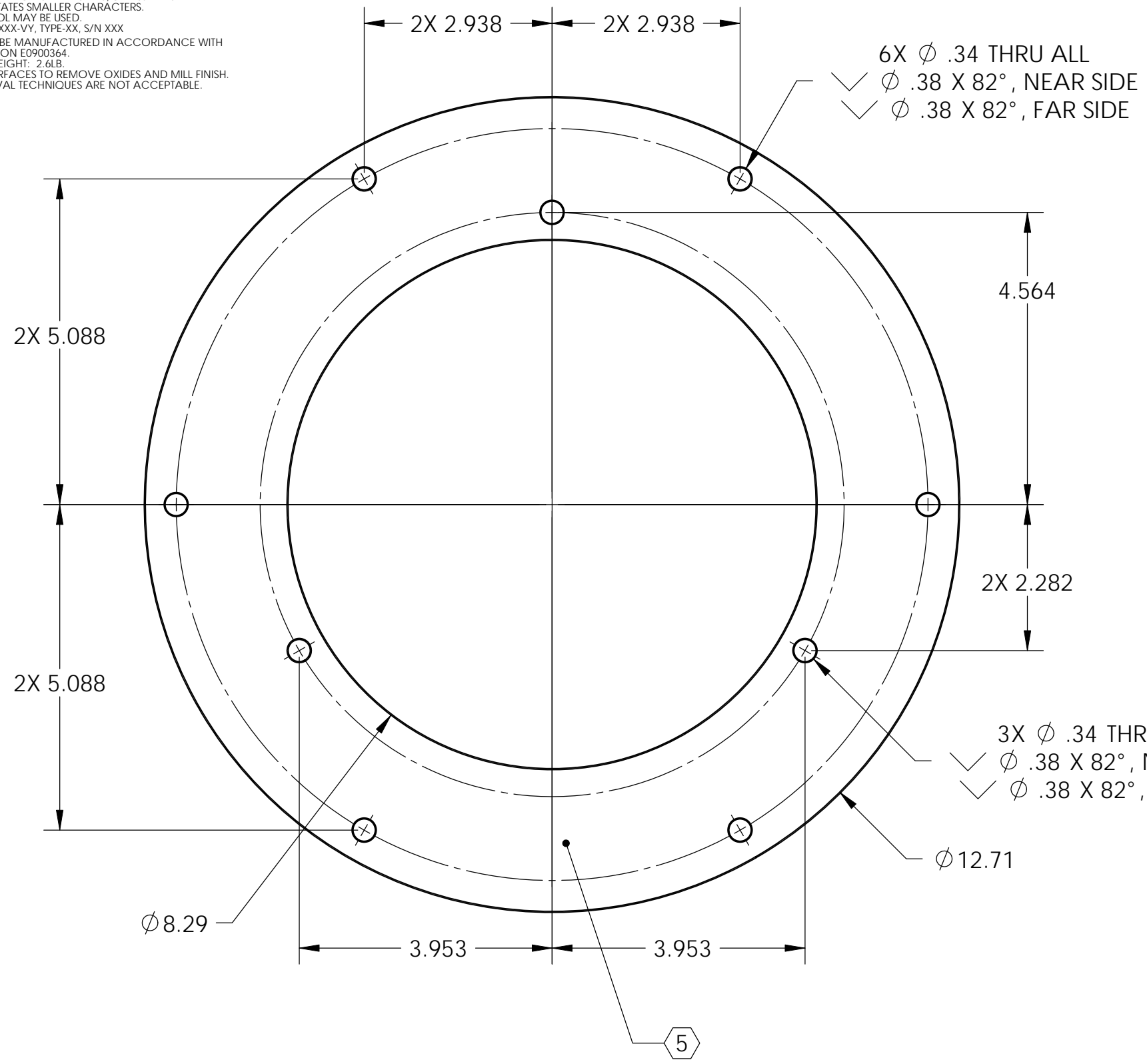

NOTES AND TOLERANCES: (UNLESS OTHERWISE SPECIFIED)				LIGO CALIFORNIA INSTITUTE OF TECHNOLOGY MASSACHUSETTS INSTITUTE OF TECHNOLOGY		PART NAME	
DIMENSIONS ARE IN INCHES		1. INTERPRET DRAWING PER ASME Y14.5-1994. 2. REMOVE ALL SHARP EDGES, R.02 MIN. 3. DO NOT SCALE FROM DRAWING. 4. ALL MACHINING FLUIDS MUST BE FULLY SYNTHETIC, FULLY WATER SOLUBLE AND FREE OF SULFUR, SILICONE, AND CHLORINE.		ADVANCED LIGO		Diaphragm, Vert GS-13, BSC ISI	
TOLERANCES: .XX ± .015 .XXX ± .005		MATERIAL 304, 316 OR 302 SSSL		SUB-SYSTEM SEI		DESIGNER S.BARNUM 5 FEB 2010	
ANGULAR ± .5°		FINISH 63 $\mu$ inch		NEXT ASSY D0902777		DRAFTER M.HILLARD 5 FEB 2010	
						CHECKER F.MATICHARD 5 FEB 2010	
						APPROVAL K.MASON 5 FEB 2010	
						SIZE DWG. NO. B D0902541	
						REV. v2	
						SCALE: 1:2 PROJECTION: SHEET 1 OF 1	