

NOTES CONTINUED:

⑤ SCRIBE, ENGRAVE, OR MECHANICALLY STAMP (NO INKS OR DYES) DRAWING PART NUMBER AND REVISION ON NOTED SURFACE FOLLOWED ON THE NEXT LINE BY A THREE DIGIT SERIAL NUMBER. SERIAL NUMBERS START AT 001 FOR THE FIRST ARTICLE AND PROCEED CONSECUTIVELY. USE .07" HIGH CHARACTERS. EXAMPLE: DXXXXXXX-VY, S/N 001. A VIBRATORY TOOL MAY BE USED.

⑥ MACHINE ALL SURFACES.

REV.	DATE	DCN #	DRAWING TREE #

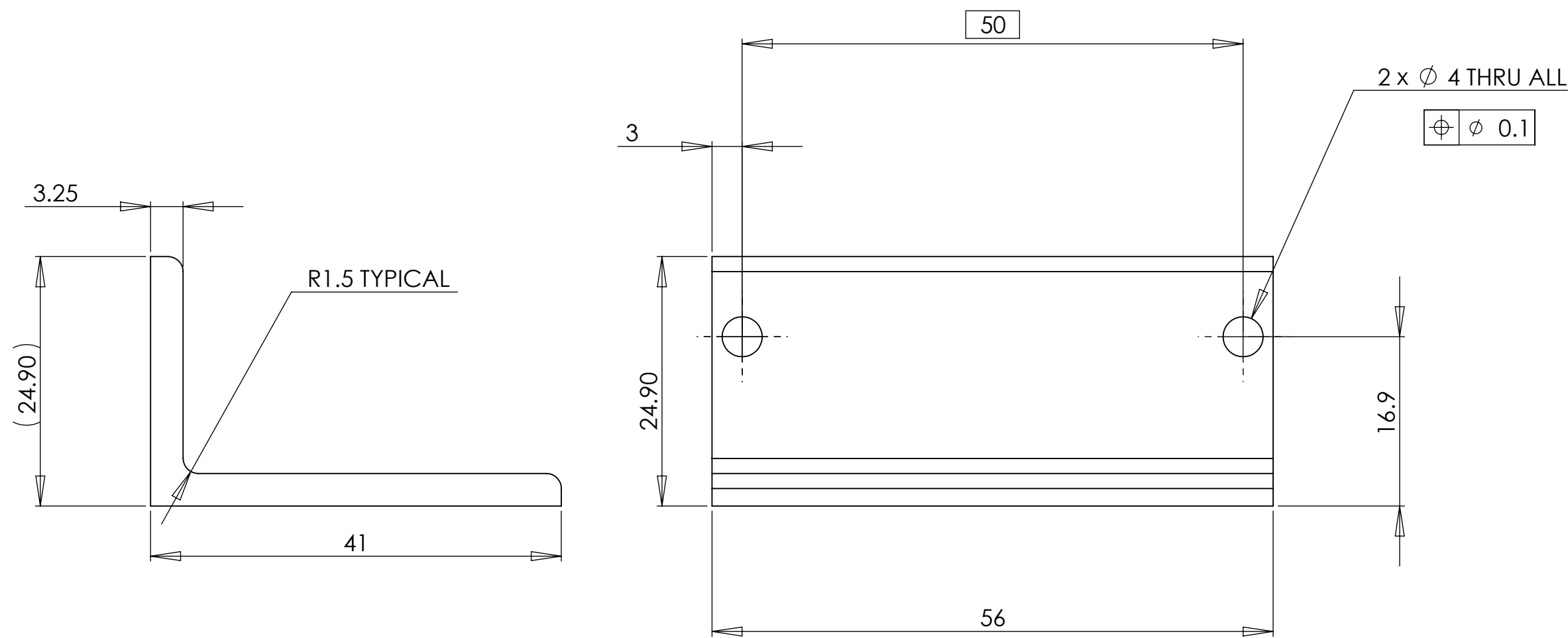
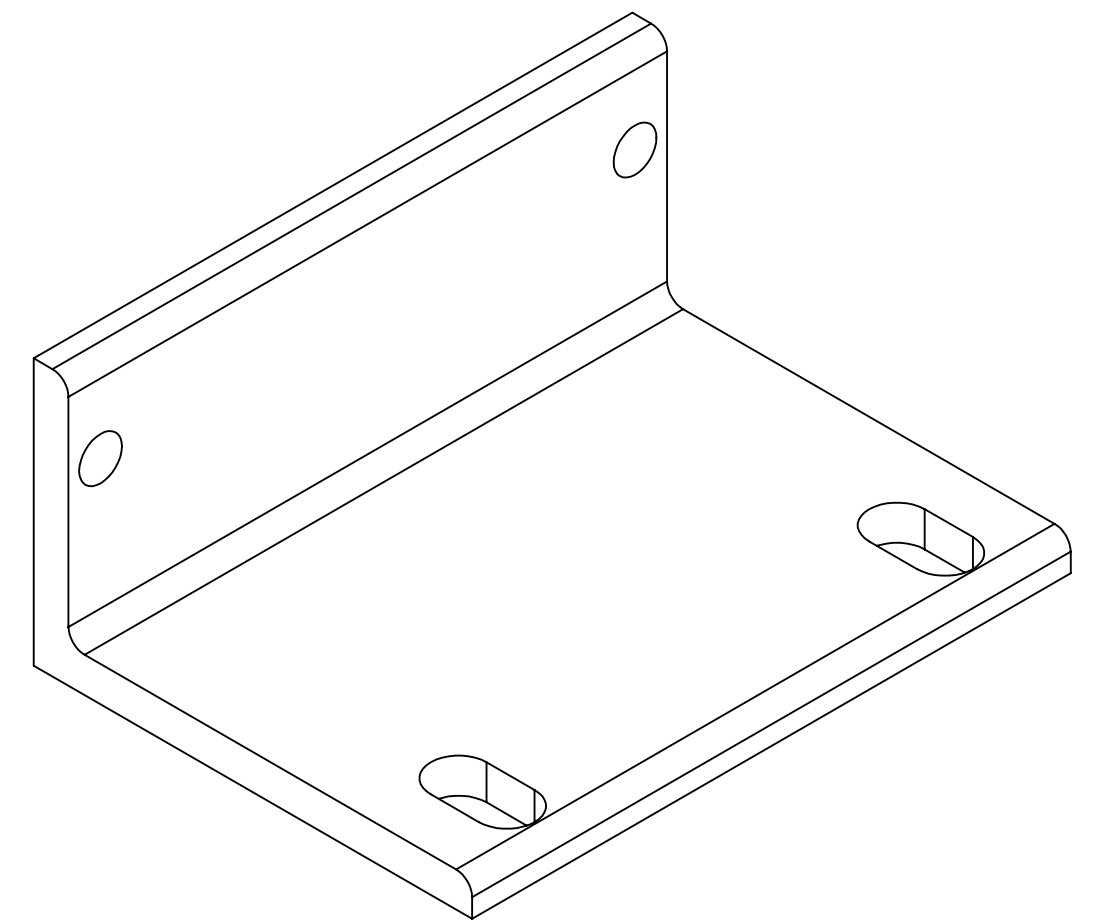
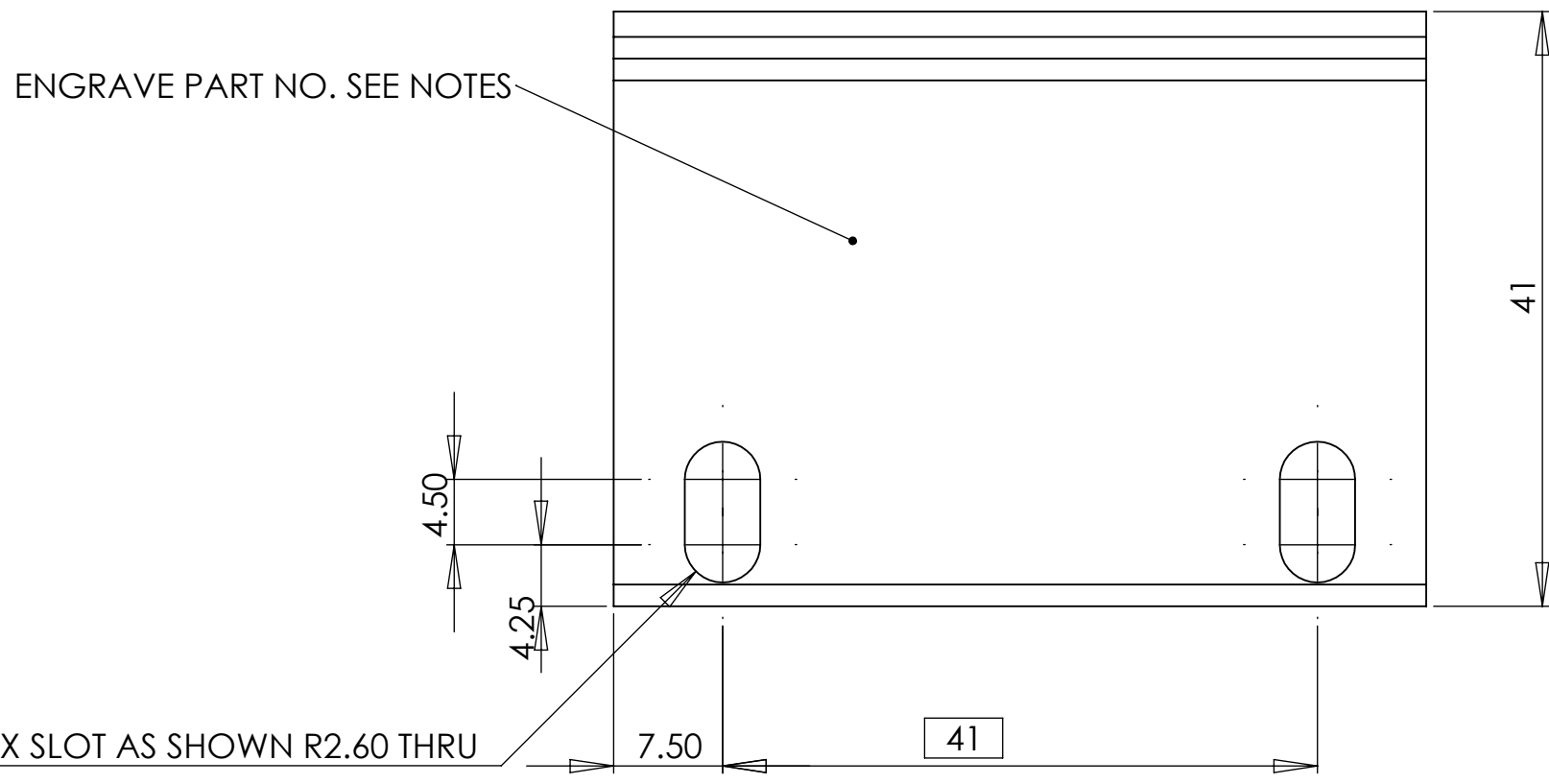

NOTES AND TOLERANCES: (UNLESS OTHERWISE SPECIFIED)

DIMENSIONS ARE IN MILLIMETERS

TOLERANCES:
 .XX ± .10
 .XXX ± .010

ANGULAR ± 0.2°

1. INTERPRET DRAWING PER ASME Y14.5-1994.
2. REMOVE ALL SHARP EDGES, R.02 MIN.
3. DO NOT SCALE FROM DRAWING.
4. ALL MACHINING FLUIDS MUST BE FULLY SYNTHETIC, FULLY WATER SOLUBLE AND FREE OF SULFUR, SILICONE, AND CHLORINE.

MATERIAL: 6061-T6 (SS)

FINISH: 0.8 μm

LIGO CALIFORNIA INSTITUTE OF TECHNOLOGY
 MASSACHUSETTS INSTITUTE OF TECHNOLOGY

SYSTEM: ADVANCED LIGO SUB-SYSTEM: SUS

NEXT ASSY

PART NAME

ANGLE SECTION 6

DESIGNER: L CUNNINGHAM 28/06/10
 DRAFTER: L CUNNINGHAM 30/06/10
 CHECKER:
 APPROVAL:

SIZE: c DWG. NO.: D0902514 REV.: v3
 SCALE: 2:1 PROJECTION: SHEET 1 OF 1