

4

3

2

1

REV.	DATE	DCN #	DRAWING TREE #
v1	15 SEP 2009	E0900302	-
-	-	-	-
-	-	-	-

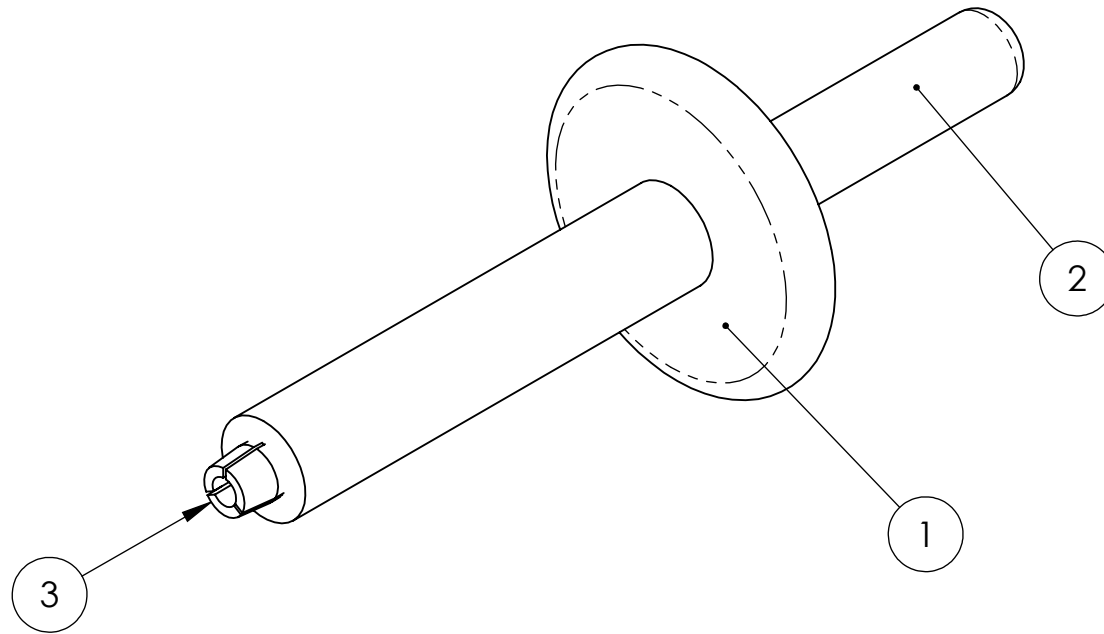

ITEM NO.	PART NUMBER	DESCRIPTION	MATERIAL	REQ	SPARE	TOTAL
3	8380T1	PENCIL MECHANISM (MCMaster CARR P/N, BEROL PENCIL PART)	N/A	1	0	1
2	D990161	PENCIL MECHANISM HOLDER	304, 316 OR 302 SSTL	1	0	1
1	D990160	BRASS PLUNGER	BRASS	1	0	1
PARTS LIST						

NOTES AND TOLERANCES: (UNLESS OTHERWISE SPECIFIED)



CALIFORNIA INSTITUTE OF TECHNOLOGY
MASSACHUSETTS INSTITUTE OF TECHNOLOGY

SYSTEM

ADVANCED LIGO

SUB-SYSTEM

SUS

NEXT ASSY

MULTIPLE ASSYS

PART NAME

PLUNGER/GRIPPER ASSY

DESIGNER J. ROMIE APR 1999

DRAFTER D. BRIDGES 5 OCT 2009

CHECKER J. ROMIE 19 OCT 2009

APPROVAL

SIZE DWG. NO.

A

D0902335

REV.

v1

SCALE: 2:1

PROJECTION:



SHEET 1 OF 1

4

3

2

1