

D

D

C

C

B

B

A

A

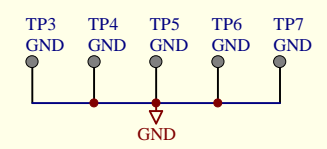
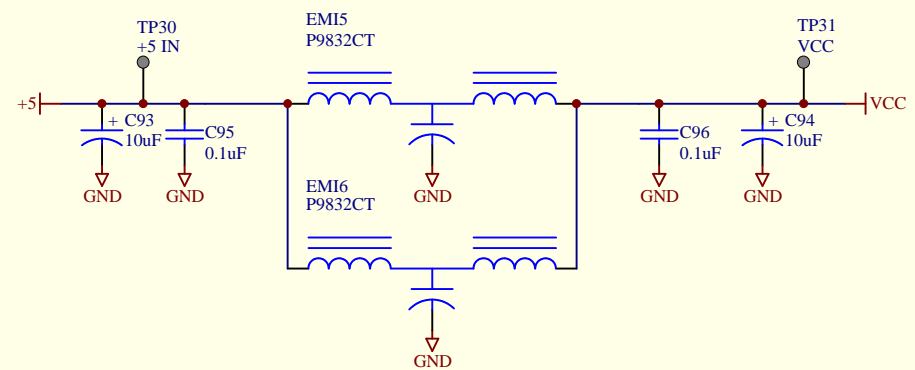
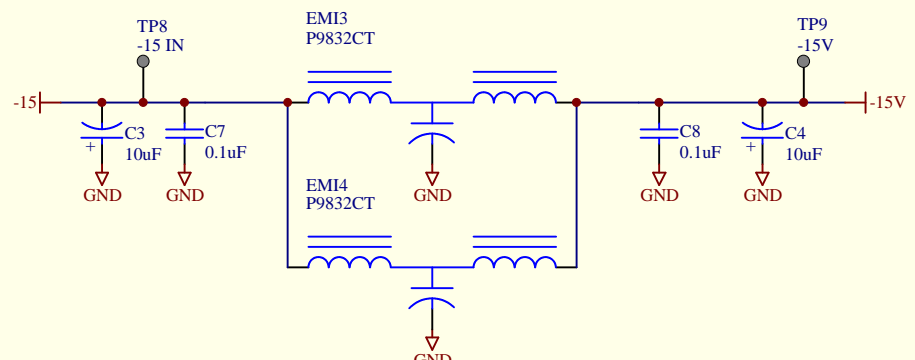
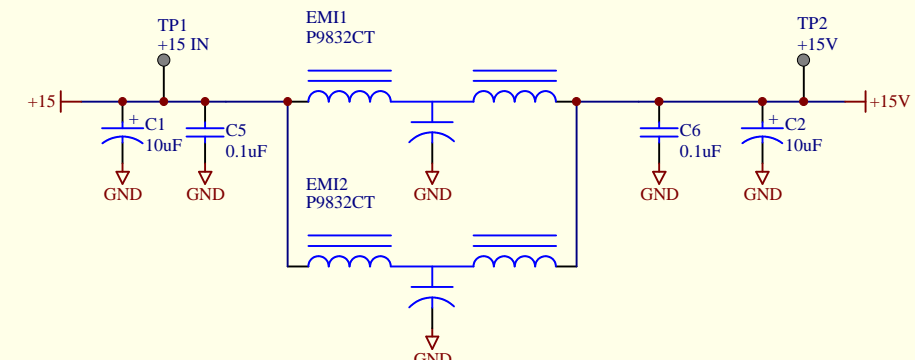
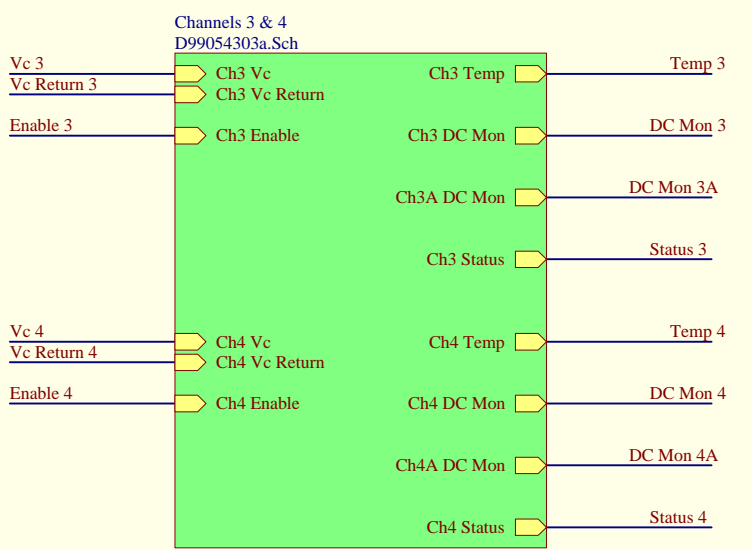
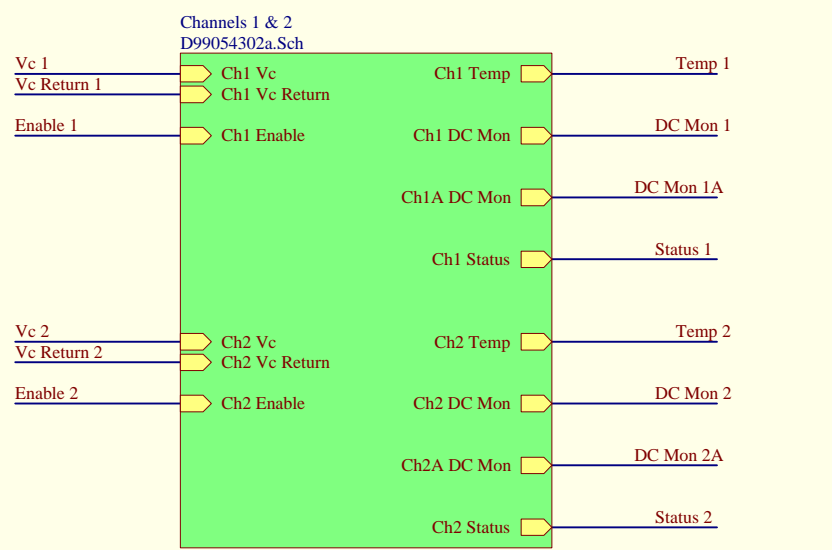
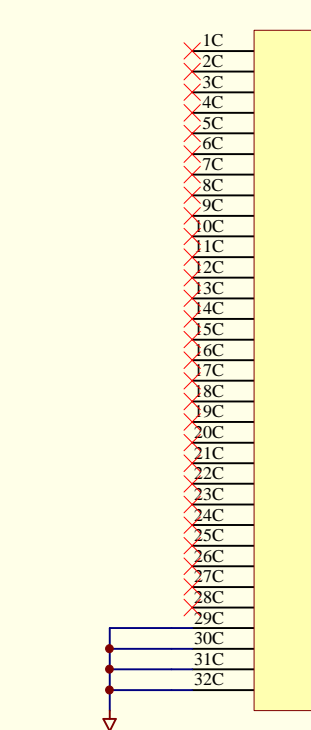
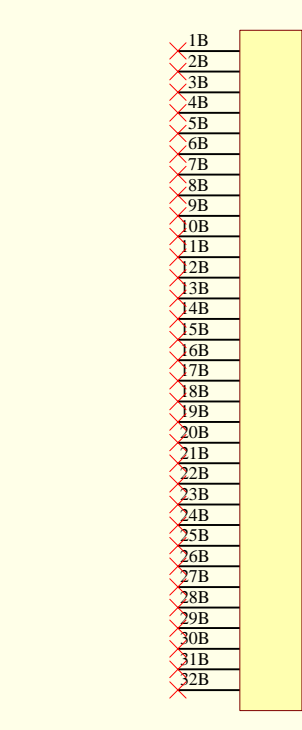
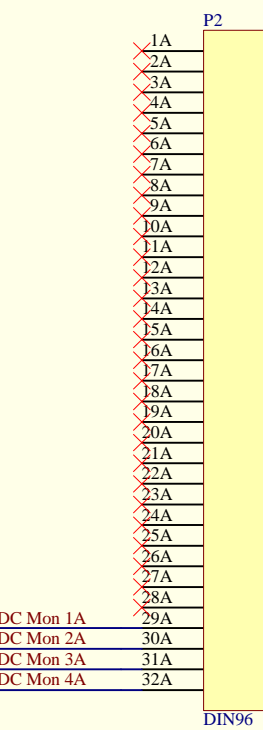
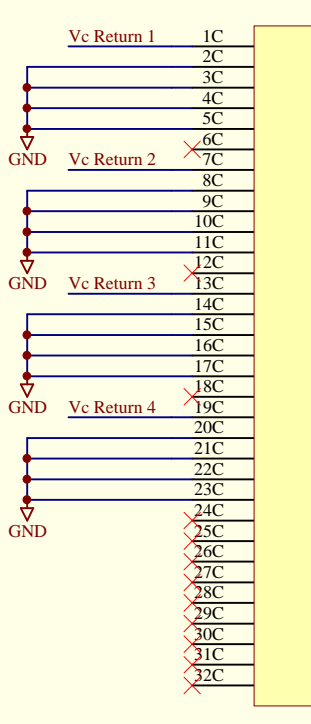
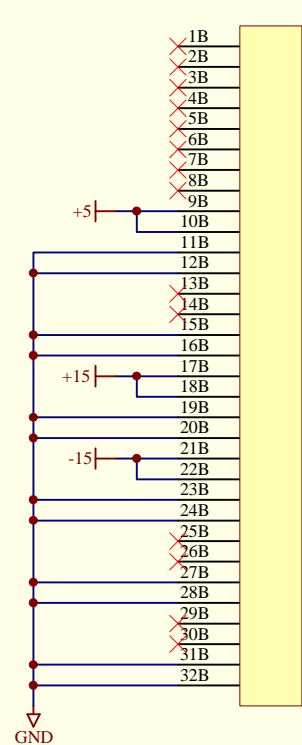
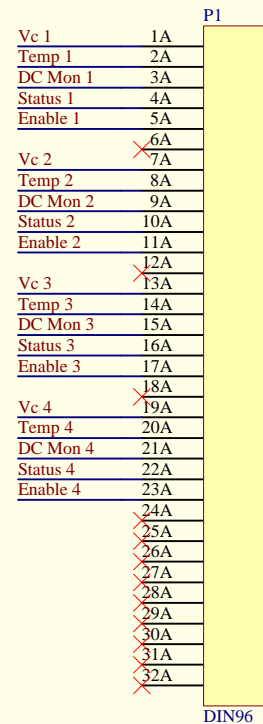

Title		Date Last Modified: 3-Dec-99	
LSC Photodiode Interface		LIGO Laboratory California Institute of Technology Massachusetts Institute of Technology	
Size: B	DCC Number: D990543-01-C	PCB / SCH Revision: A / 01	Engineer: D. Ouimette
File: S:\Systems\LSC\PD Interface\Ver A Fred\Mod 01\D99054301a.prj		Date: 3-Dec-1999	Time: 14:54:38
		Sheet 1 of 3	

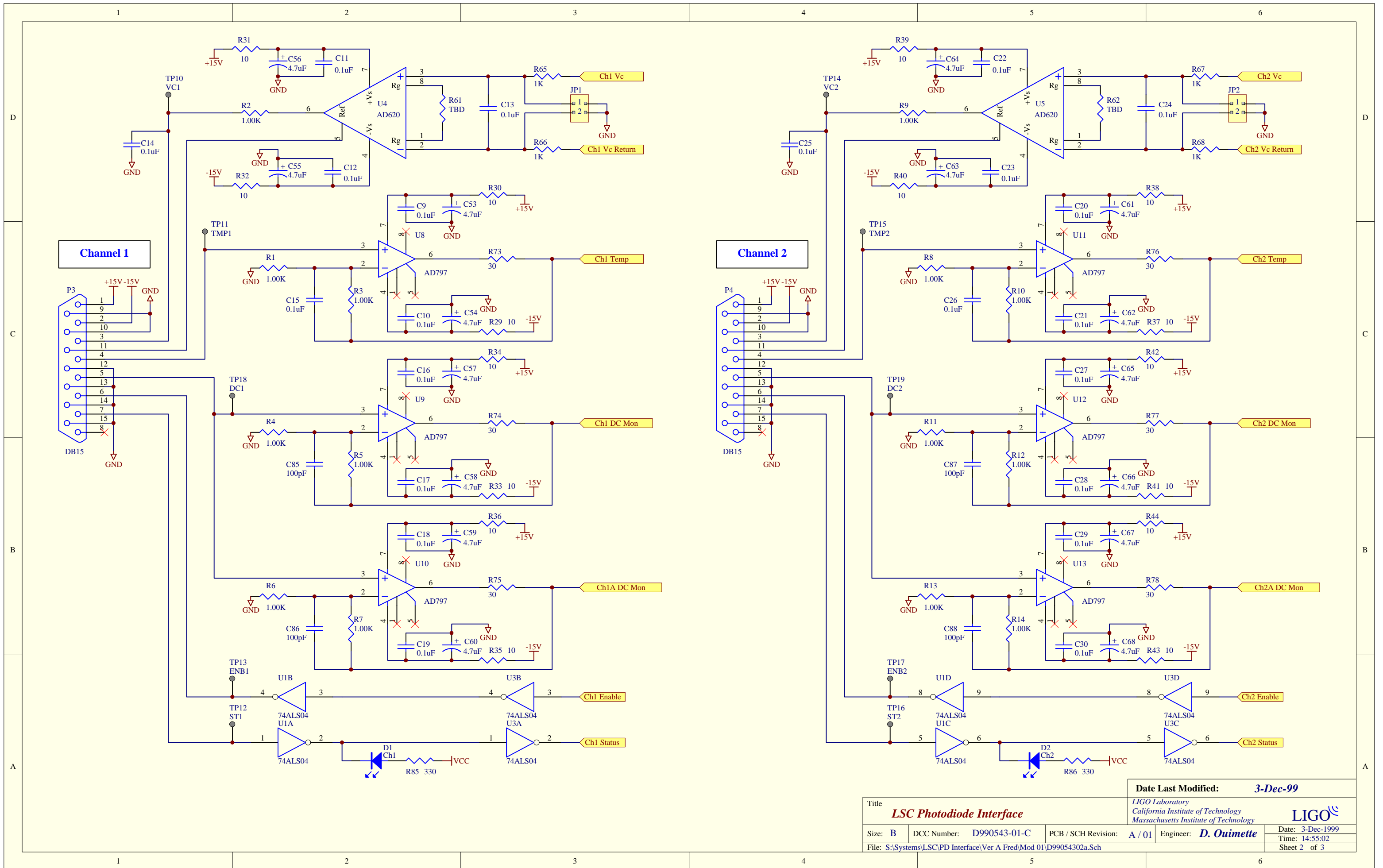

Date Last Modified: 3-Dec-99

Title
LSC Photodiode Interface

LIGO Laboratory
California Institute of Technology
Massachusetts Institute of Technology



Size: B	DCC Number: D990543-01-C	PCB / SCH Revision: A / 01	Engineer: D. Ouimette	Date: 3-Dec-1999
File: S:\Systems\LSC\PD Interface\Ver A\Fred\Mod 01\D99054302a.Sch				Time: 14:55:02
				Sheet 2 of 3

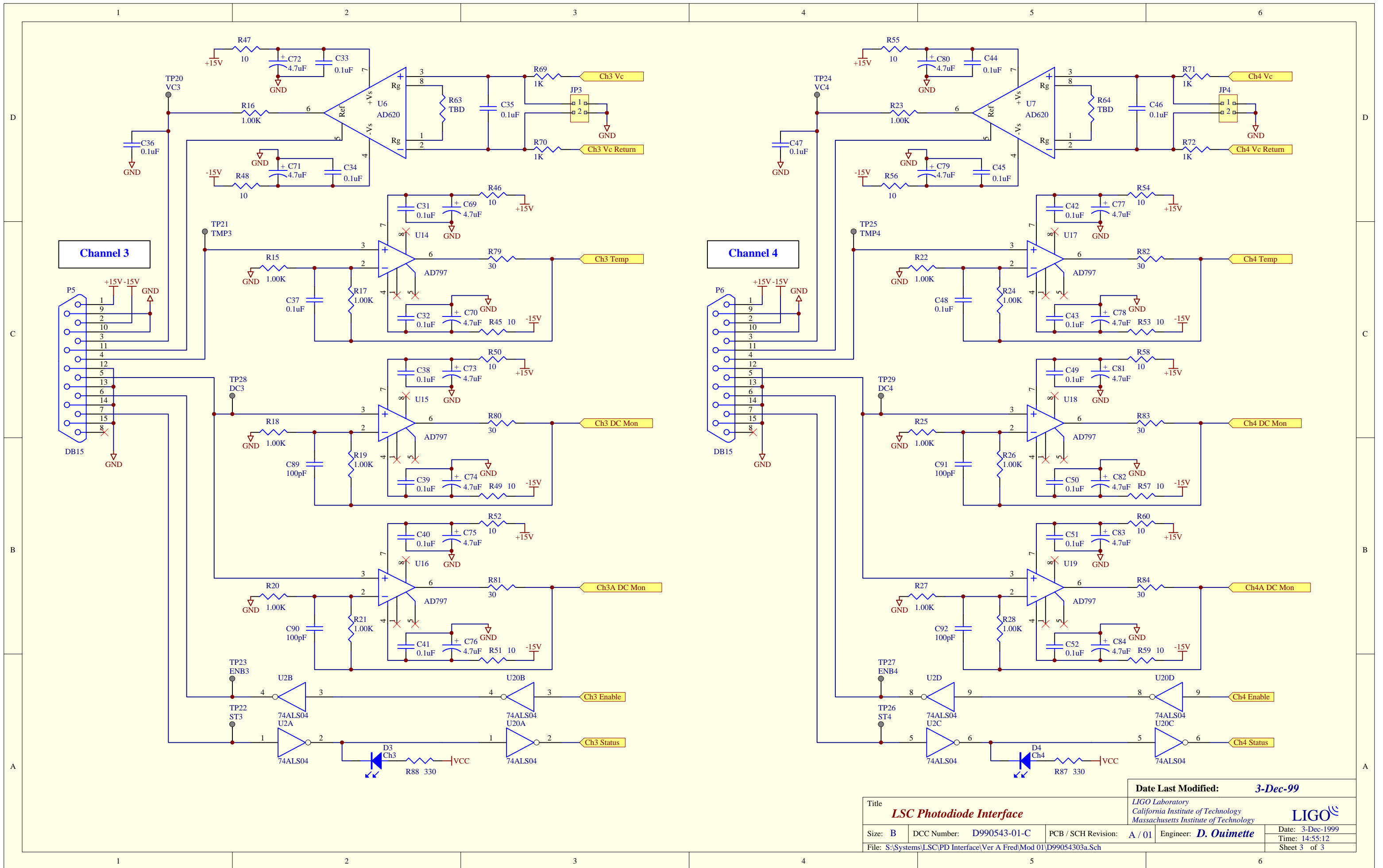

Date Last Modified: 3-Dec-99

Title		LIGO Laboratory California Institute of Technology Massachusetts Institute of Technology		LIGO	
Size: B	DCC Number: D990543-01-C	PCB / SCH Revision: A / 01	Engineer: D. Ouimette	Date: 3-Dec-1999	
File: S:\Systems\LSC\PD Interface\Ver A Fred\Mod 01\D99054303a.Sch				Time: 14:55:12	Sheet 3 of 3