

4

3

2

1

NOTES:
 ① HELICOILS TO BE INSTALLED INTO ITEM NO. 1 BY LIGO PRIOR TO ASSEMBLY AND AFTER ALL PARTS ARE CLEANED AND BAKED.

REV.	DATE	DCN #	DRAWING TREE #
v1	16 JUN 2010	E0900504	E0900353
v2	20 JUN 2011	E1100590	E0900353
-	-	-	-

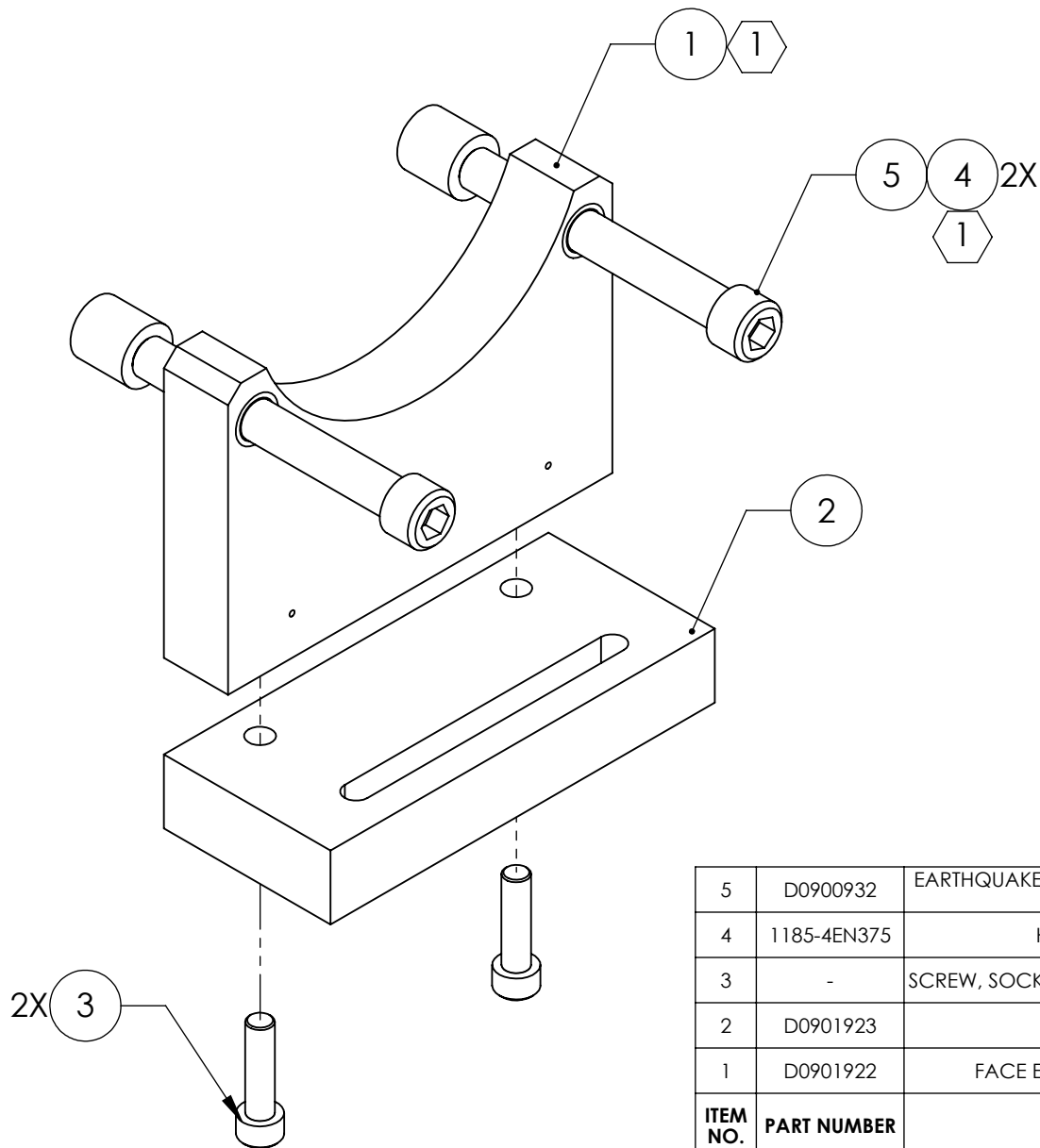

5	D0900932	EARTHQUAKE STOP FOR GLASS (GLASS TIP), SIMPLIFIED, 2 INCH	N/A	2		2
4	1185-4EN375	HELICOIL, 1/4-20 X 0.375 LONG ①	NITRONIC 60	2		2
3	-	SCREW, SOCKET HEAD CAP, #8-32 UNC-2A X 0.625 LONG	300 SSSL	2		2
2	D0901923	HSTS FACE EQ STOP BASE	6061-T6 Al	1		1
1	D0901922	FACE EQ STOP BRACKET, HSTS LOWER MASS ①	6061-T6 Al	1		1
ITEM NO.	PART NUMBER	DESCRIPTION	MATERIAL	REQ	SPARE	TOTAL

PARTS LIST

CALIFORNIA INSTITUTE OF TECHNOLOGY MASSACHUSETTS INSTITUTE OF TECHNOLOGY		PART NAME		FACE EQ STOP ASSY, BOTTOM MASS					
SYSTEM	ADVANCED LIGO	SUB-SYSTEM	SUS	DESIGNER	B. MOORE	14 OCT 2009	SIZE	DWG. NO.	REV.
NEXT ASSY	D020700			DRAFTER	B. MOORE	14 JUN 2012	A	D0902205	v2
				CHECKER	D. BRIDGES	14 JUN 2012			
				APPROVAL			SCALE: 1:1	PROJECTION:	SHEET 1 OF 1

4

3

2

1