

NOTES CONTINUED:  
 5. SCRIBE, ENGRAVE, OR MECHANICALLY STAMP (NO INKS OR DYES) DRAWING PART NUMBER, REVISION (AND VARIANT OR "TYPE" IF APPLICABLE) ON NOTED SURFACE OF PART FOLLOWED ON THE NEXT LINE WITH A THREE DIGIT SERIAL NUMBER. SERIAL NUMBERS START AT 001 FOR THE FIRST ARTICLE AND PROCEED CONSECUTIVELY. USE MINIMUM 0.12" HIGH CHARACTERS, UNLESS THE SIZE OF THE PART DICTATES SMALLER CHARACTERS. A VIBRATORY TOOL MAY BE USED. EXAMPLE: DXXXXXX-VY, TYPE-XX, S/N XXX

6. FOR ASSEMBLY PROCEDURES FOR COC OPTIC CONTAINER REFER TO DCC DOCUMENT LIGO-E0900394  
<https://dcc.ligo.org/LIGO-E0900394/public>

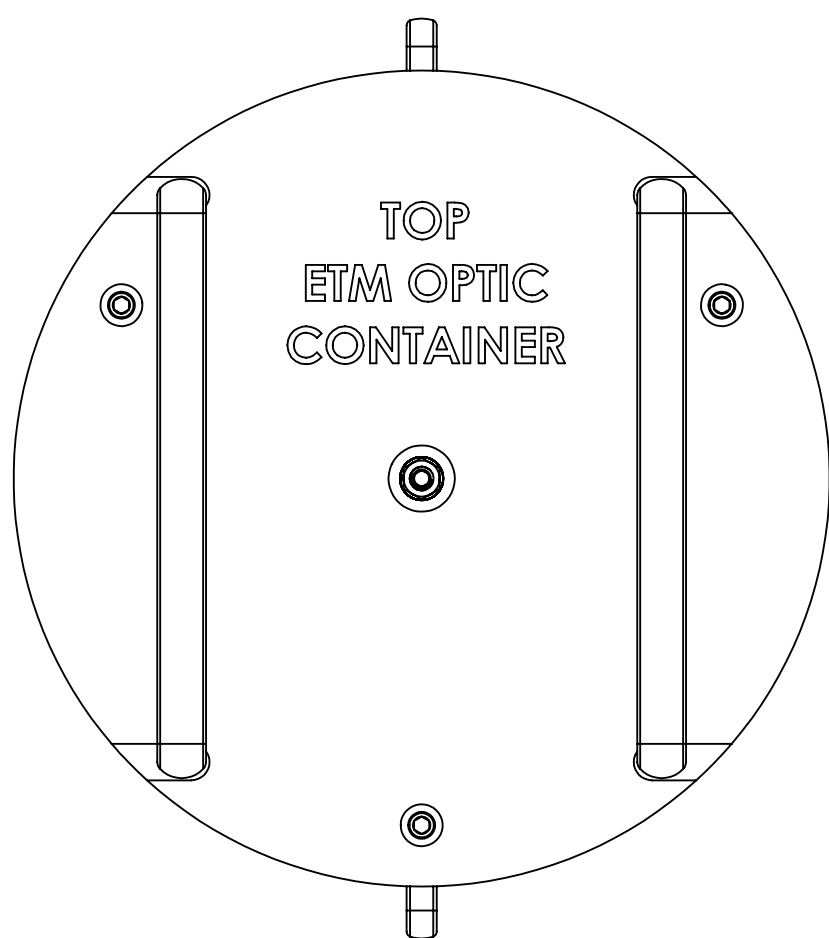
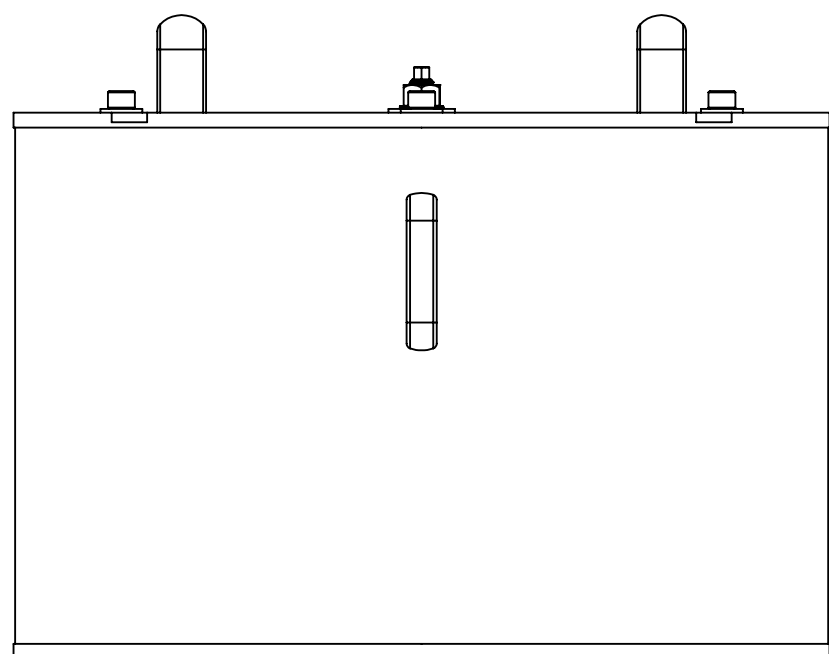

REV.	DATE	DCN #	DRAWING TREE #
v4	11 OCT 2019	E1900320-x0	
v3	29 APR 2010	E1000141	
v1	21 OCT 2009	E0900367	

ITEM NO.	PART NUMBER	DESCRIPTION	MATERIAL	REQ	SPARE	TOTAL
ALT	D0902523-4	OVERSIZE LOCATING SLEEVE, ETM, COC CONTAINER	PFA440HP	1		1
ALT	D0902523-3	OVERSIZE LOCATING SLEEVE, ETM, COC CONTAINER	PFA440HP	1		1
ALT	D0902523-2	OVERSIZE LOCATING SLEEVE, ETM, COC CONTAINER	PFA440HP	1		1
ALT	D0902523-1	OVERSIZE LOCATING SLEEVE, ETM, COC CONTAINER	PFA440HP	1		1
ALT	D0902495	GUIDE, OPTIC, COC CONTAINER	PFA440HP	3		3
30	AS568A-453 O-RING	ROW INC. O-RING, .275" THICK X 11.975" ID, PFA Encapsulated Viton	VITON	2		2
29	ROW Inc.	O-Ring, Base FM, .188 Thick X 16.375 ID	PFA Encapsulated Viton	2		2
28	D0902536	PULL HANDLE, MODIFIED MC #1897A49	6061-T6 Al	2		2
27	D0902490	COVER, CENTRYCO CC-22-025-0050-013-DAE	301 SSSL	1		1
26	D0902348	Plate, Adjustable, ETM Optic Container	303 SS	2		2
25	D0902331	RETAINER FOR CENTRYCO COVER	304 SSSL	1		1
24	D0902330	PILOT FOR CENTRYCO COVER	304 SSSL	1		1
23	D0902246	TOP PLATE, ETM, COC OPTIC CONTAINER	6061-T6 Al	1		1
22	D0902152	SHIPPING SLEEVE, ETM, COC CONTAINER	6061-T6 Al	3		3
21	D0902151	OUTER SLEEVE, ETM, COC CONTAINER	304 SSSL	1		1
20	D0902150	LOCATING SLEEVE, ETM, COC CONTAINER	PFA440 HP (PRESHRUNK)	3		3
19	D0902149	LOCATING SHAFT, ETM, COC CONTAINER	304 SSSL	3		3
18	D0902148	WEDGE PLATE, ETM, COC OPTIC CONTAINER	6061-T6 Al	1		1
17	D0902147	BASE PLATE, ETM, COC OPTIC CONTAINER	6061-T6 Al	1		1
16	D0902028	THRUST PAD, WEDGE PLATE CLAMP, COC CONTAINER	17-4 PH SS	1		1
15	D0902027	PULL HANDLE, 337LB LOAD RATED	6061-T6 Al	2		2
14	D0902026	CLAMP, WEDGE PLATE, COC CONTAINER	300 SSSL	1		1
13	D0901316	Block, Spring Loaded, Adjustable, ETM Optic Container	PFA 440 HP	2		2
12	C-606-N	SCREW, SHC, 6-32 x 3/8, (UC Comp #C-606-N)	300 SSSL	4		4
11	C-2024-N	Screw, Soc Hd Cap, 1/4-20 x 1.50 (UC Comp #C-2024-N)	18-8 SS	4		4
10	98449A033	WASHER, LOCK, INT TOOTH 1/2", ASME B18.21.1 MC #98449A033	410 SSSL	1		1
9	98019A510	WASHER, FLAT, 1/2, MS15795-819, MC #98019A510	18-8 SSSL	1		1
8	98019A399	WASHER, FLAT, 3/8, MS15795-814, MC #98019A399	18-8 SSSL	3		3
7	92200A682	SCREW, SHC, 3/8-16 x 1 1/4, MS16995-82, MC #92200A682	18-8 SSSL	3		3
6	92200A630	SCREW, SHC, 5/16-18 x 1, MS16995-66, MC #92200A630	18-8 SSSL	4		4
5	92200A340	SCREW, SHC, 10-32 x 3/8, MS16995-9, MC #92200A340	18-8 SSSL	4		4
4	92200A144	SCREW, SHC, 6-32 x 1/4, MS16995-16, MC#92200A144	300 SSSL	4		4
3	90762A139	1/2 HEX NUT, MS51972-5, MC #90762A139	300 SSSL	1		1
2	1986K1	Spring, Compressed, Closed end, 5/32 OD x .016 x 1.00	Stainless Steel	2		2
1	1726A7	PULL HANDLE, MC #1726A7	304 SSSL	2		2

NOTES AND TOLERANCES: (UNLESS OTHERWISE SPECIFIED)

DIMENSIONS ARE IN INCHES  
 TOLERANCES:  
 .XX ± .01  
 .XXX ± .005  
 ANGULAR ± 0.5°

1. INTERPRET DRAWING PER ASME Y14.5-1994. 2. REMOVE ALL SHARP EDGES, .005-.015, FOR MACHINED PARTS. ROUND ALL EDGES APPROXIMATELY R.02 FOR SHEET METAL PARTS. 3. DO NOT SCALE FROM DRAWING. 4. ALL MACHINING FLUIDS MUST BE FULLY SYNTHETIC, FULLY WATER SOLUBLE AND FREE OF SULFUR, SILICONE, AND CHLORINE.	
MATERIAL	N/A
FINISH	N/A μinch

**LIGO** CALIFORNIA INSTITUTE OF TECHNOLOGY  
 MASSACHUSETTS INSTITUTE OF TECHNOLOGY

SYSTEM: **ADVANCED LIGO** SUB-SYSTEM: **COC**

NEXT ASSY

PART NAME: **ETM, COC CONTAINER ASSEMBLY**

DESIGNER	K. BUCKLAND	23 AUG 2009	SIZE	DWG. NO.	REV.
DRAFTER	K. BUCKLAND	29 SEPT 2009	c	<b>D0902146</b>	v4
CHECKER	K. MAILAND	21 OCT 2009			
APPROVAL	C. TORRIE	21 OCT 2009	SCALE: 1:4	PROJECTION:	SHEET 1 OF 5

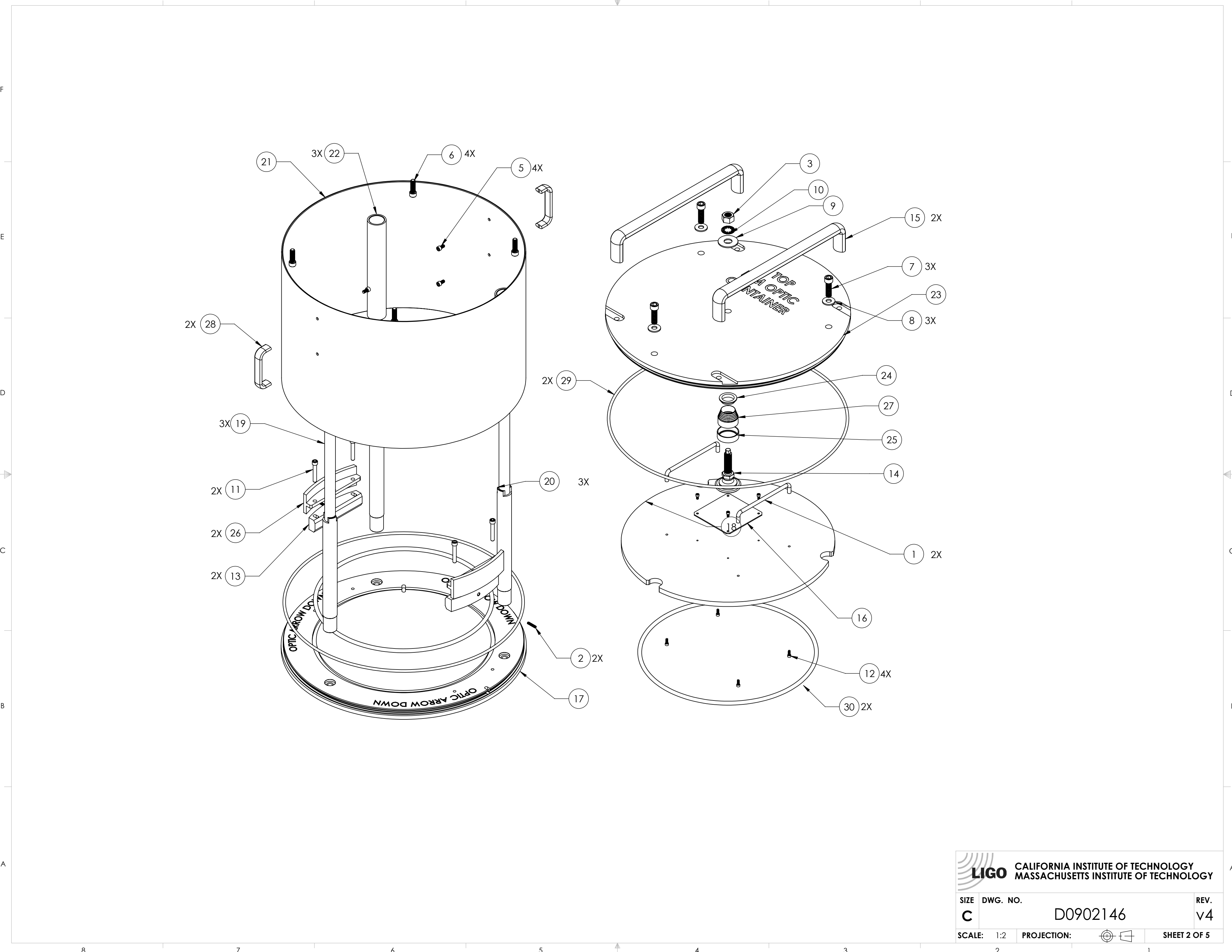

**LIGO** CALIFORNIA INSTITUTE OF TECHNOLOGY  
 MASSACHUSETTS INSTITUTE OF TECHNOLOGY

SIZE <b>C</b>	DWG. NO. D0902146	REV. v4
SCALE: 1:2	PROJECTION:	SHEET 2 OF 5

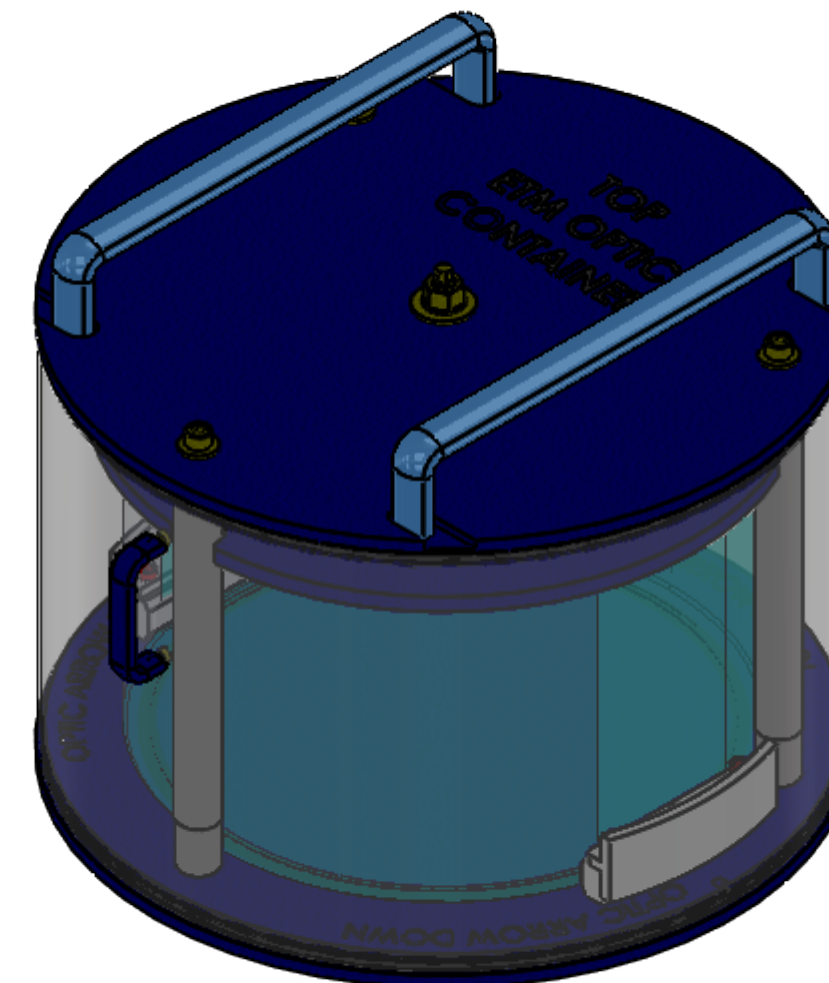
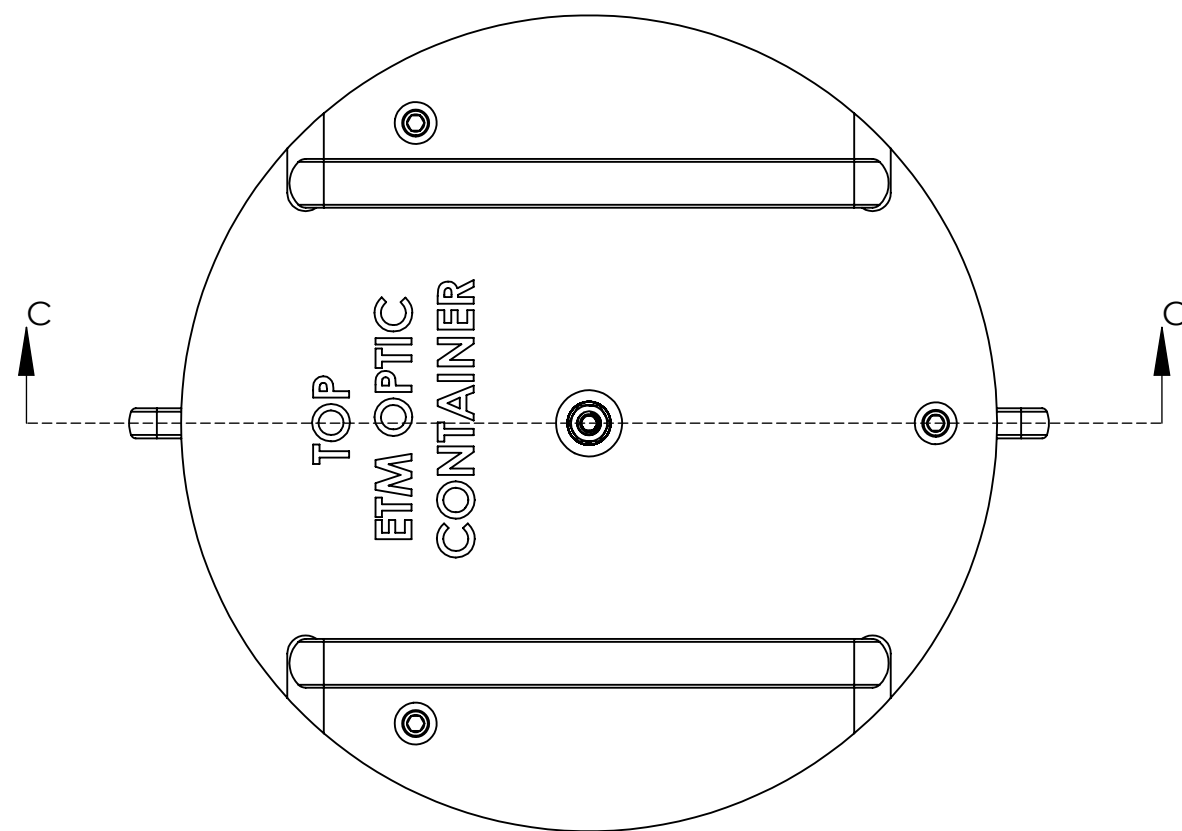

ISOMETRIC VIEW  
OUTER SLEEVE TRANSPARENT

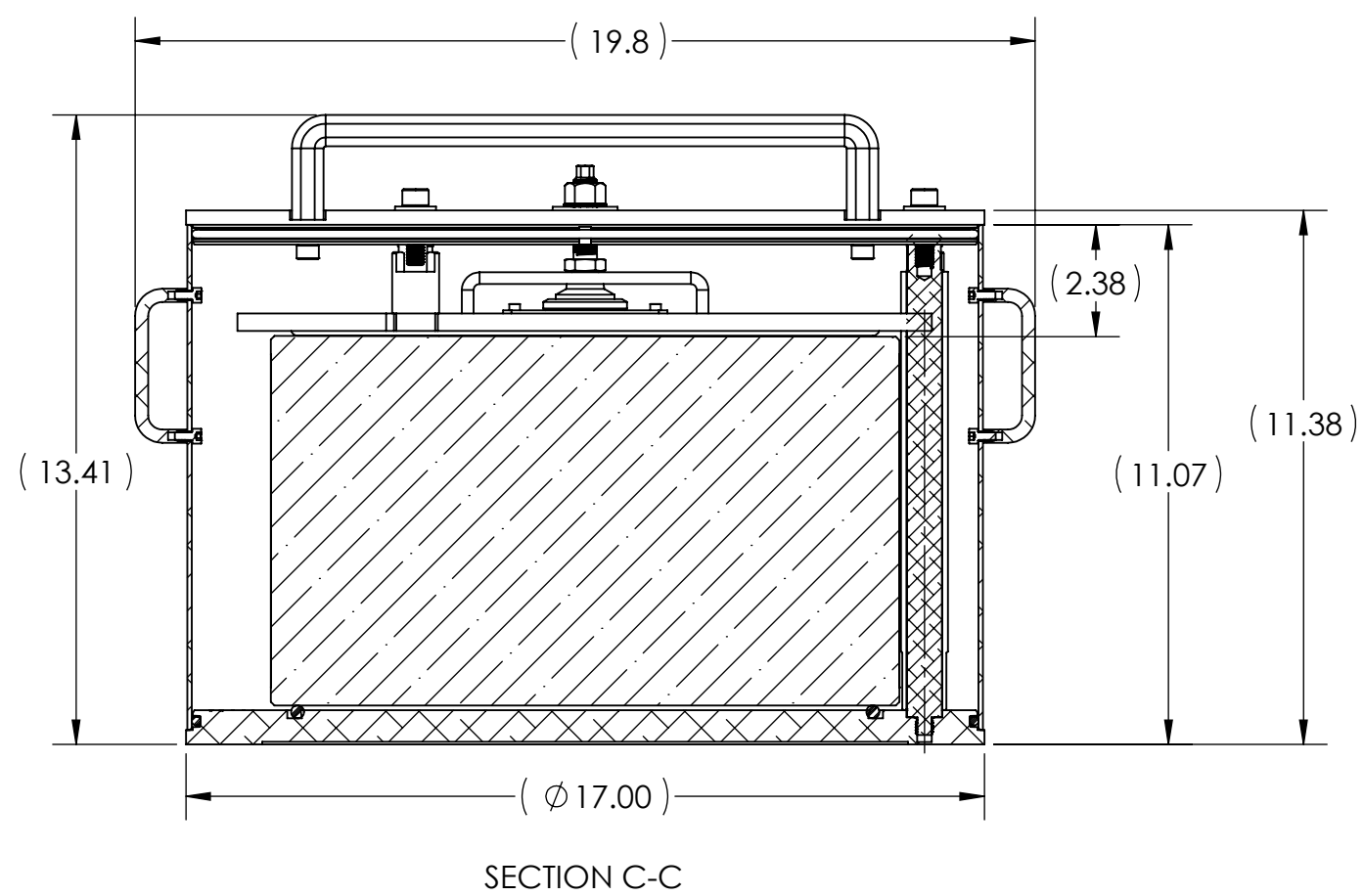

SECTION C-C

 <b>CALIFORNIA INSTITUTE OF TECHNOLOGY</b> <b>MASSACHUSETTS INSTITUTE OF TECHNOLOGY</b>		
SIZE <b>C</b>	DWG. NO. <b>D0902146</b>	REV. <b>v4</b>
SCALE: 1:4	PROJECTION: 	SHEET 3 OF 5

6. FOR ASSEMBLY PROCEDURES FOR COC OPTIC CONTAINER  
 REFER TO DCC DOCUMENT LIGO-E0900394  
<https://dcc.ligo.org/LIGO-E0900394/public>

ETM OPTIC  
 FOR REFERENCE ONLY

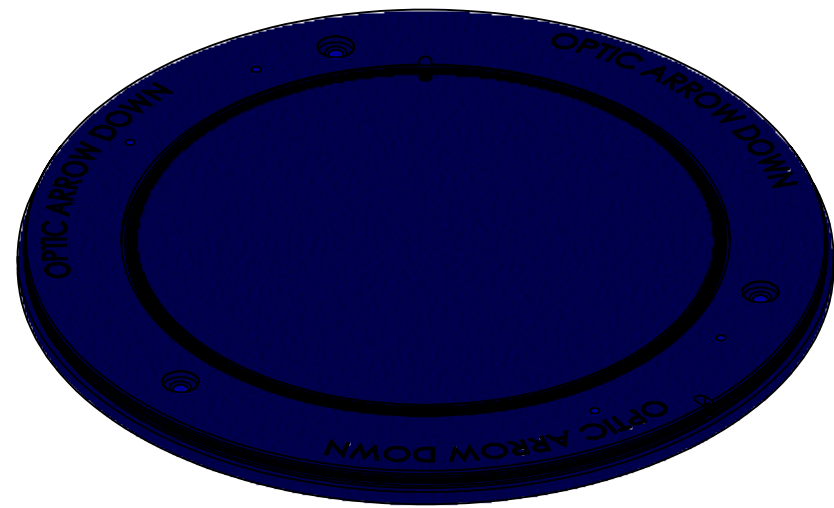

ASSY STEP 01

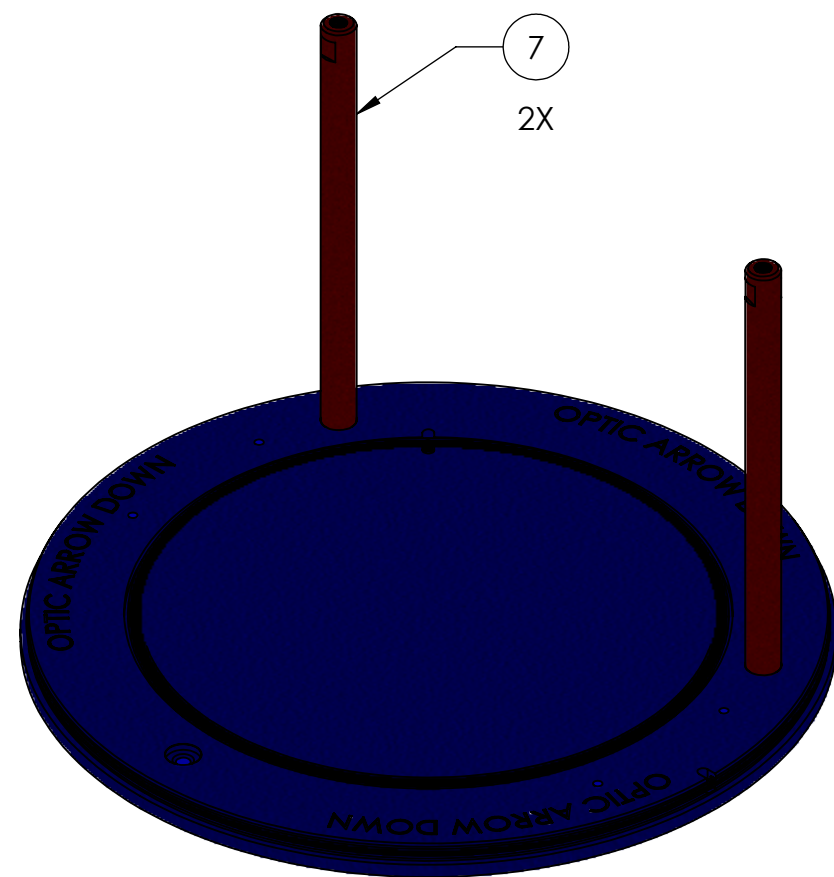

ASSY STEP 02

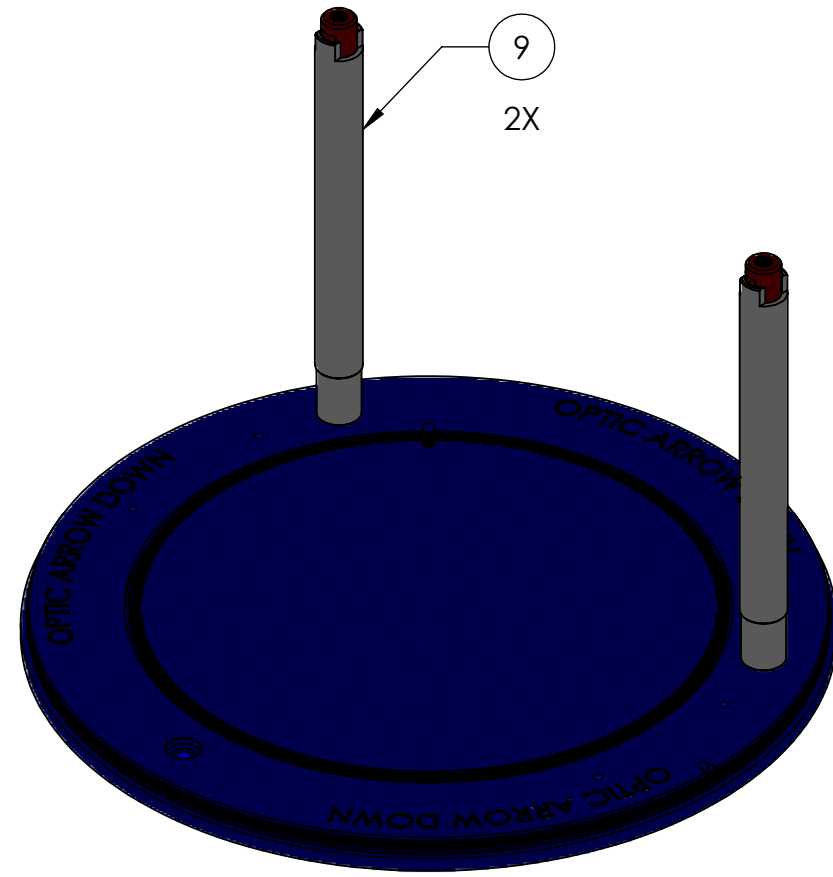

ASSY STEP 03

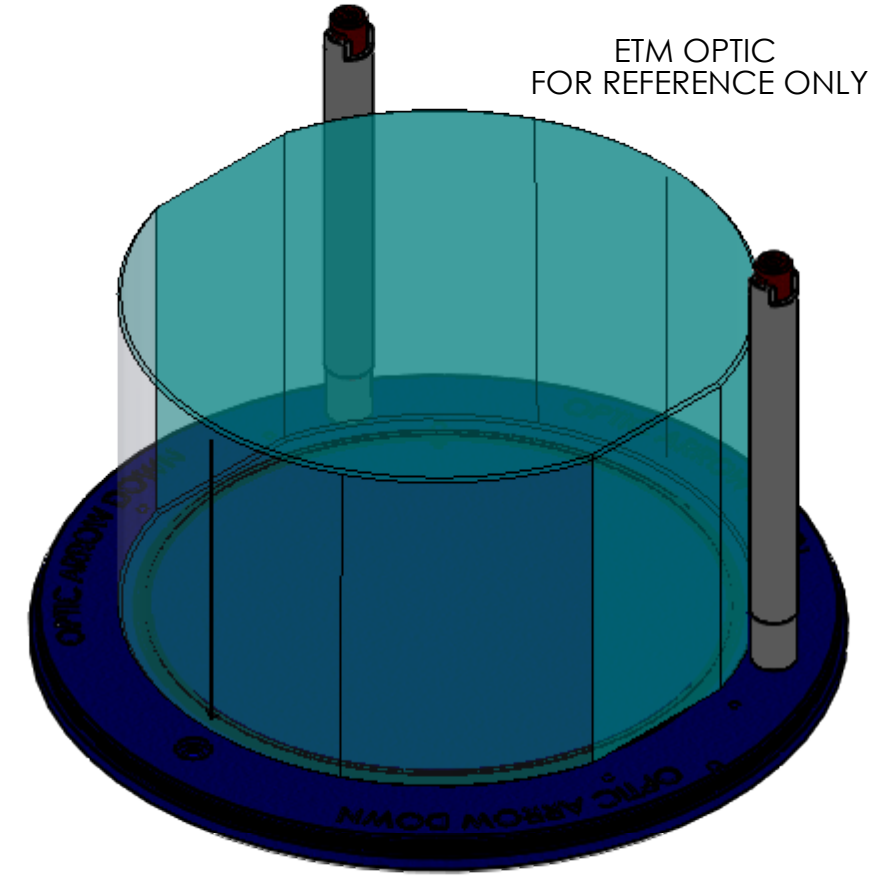

ASSY STEP 05

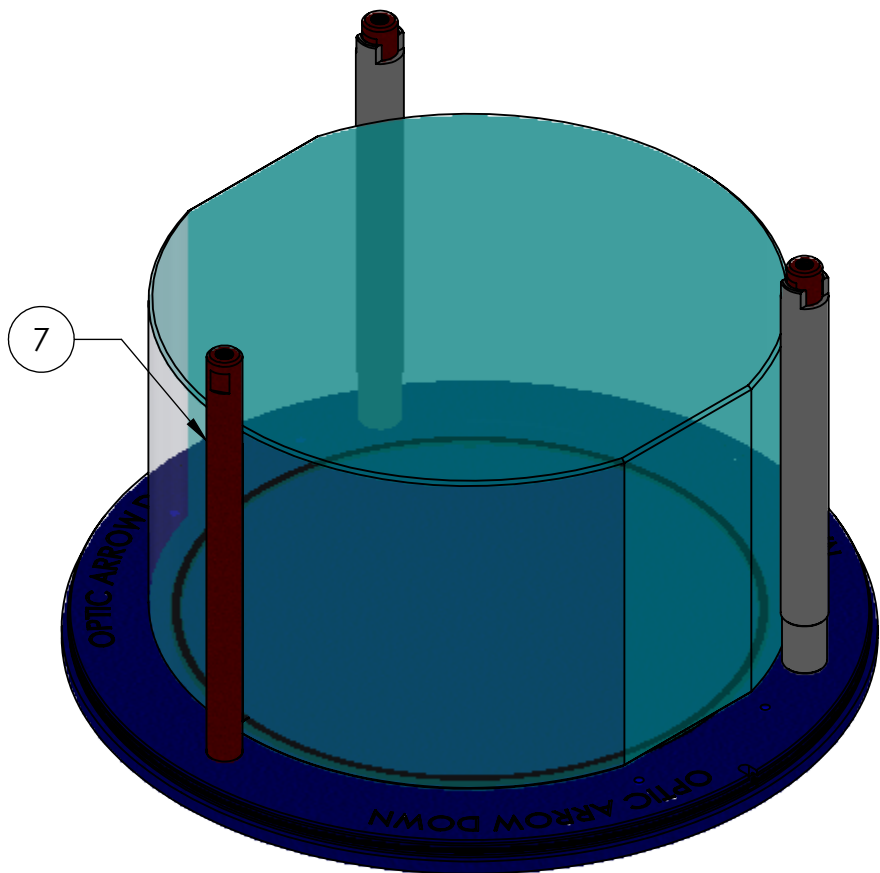

ASSY STEP 06

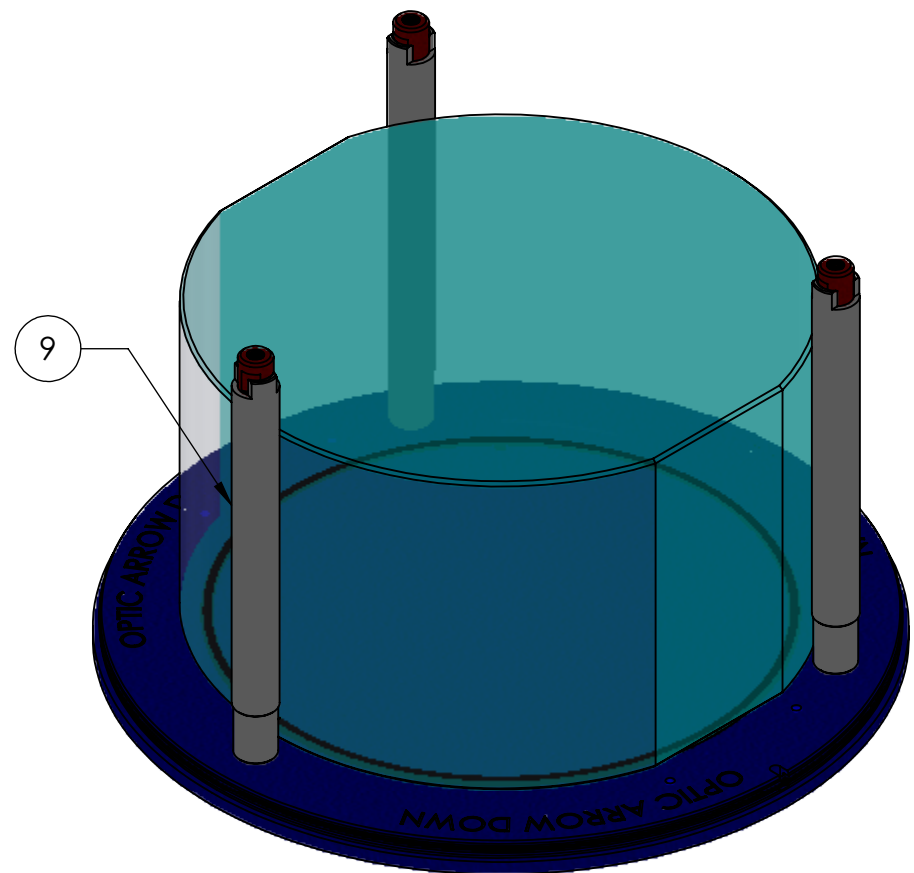

ASSY STEP 07

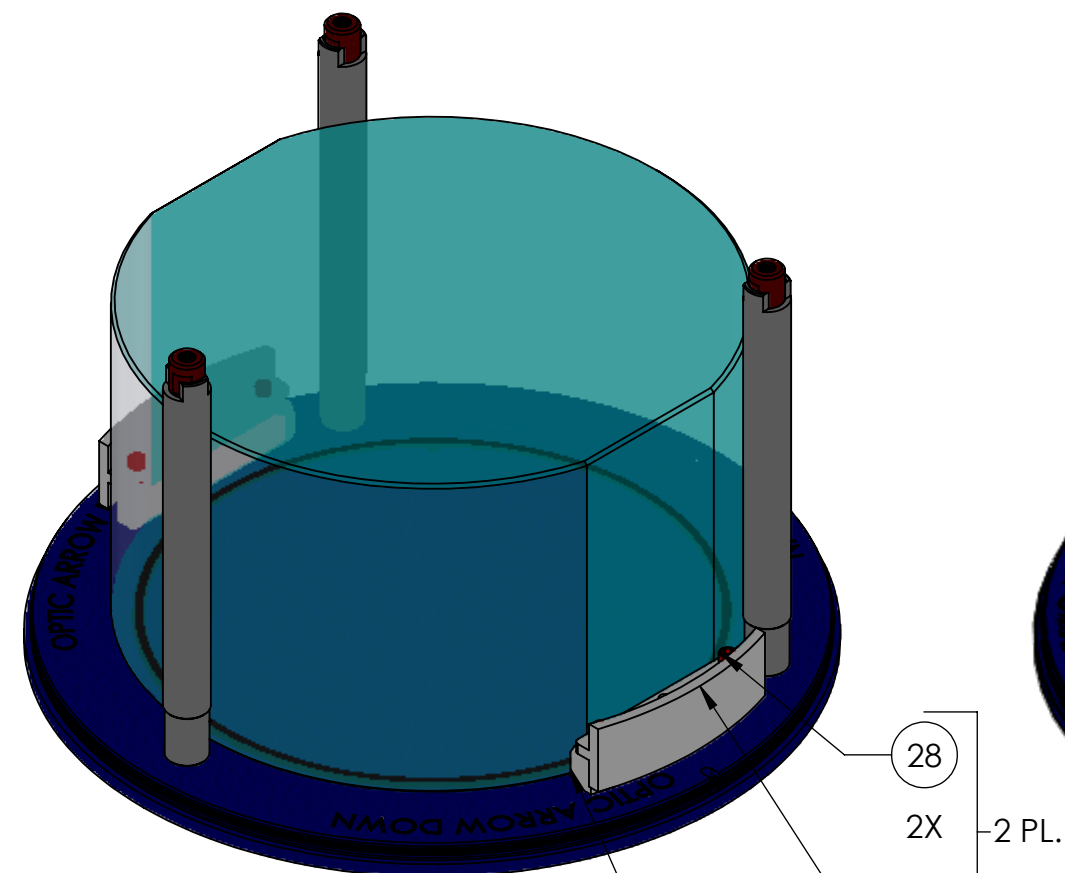

ASSY STEP 09

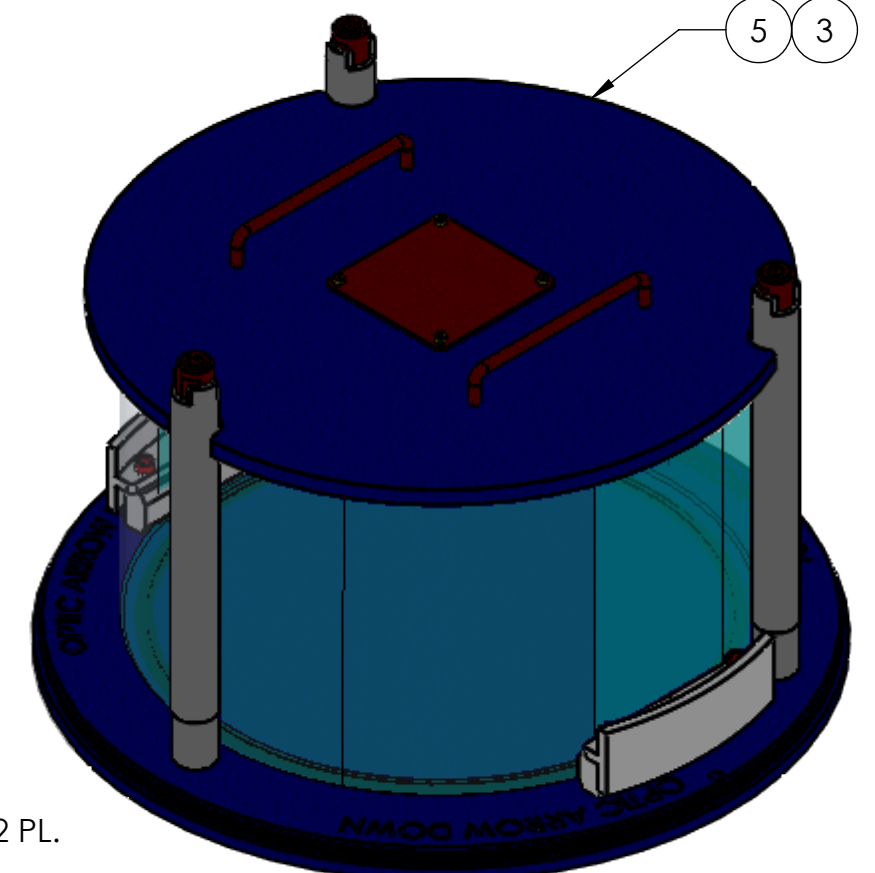

ASSY STEP 11

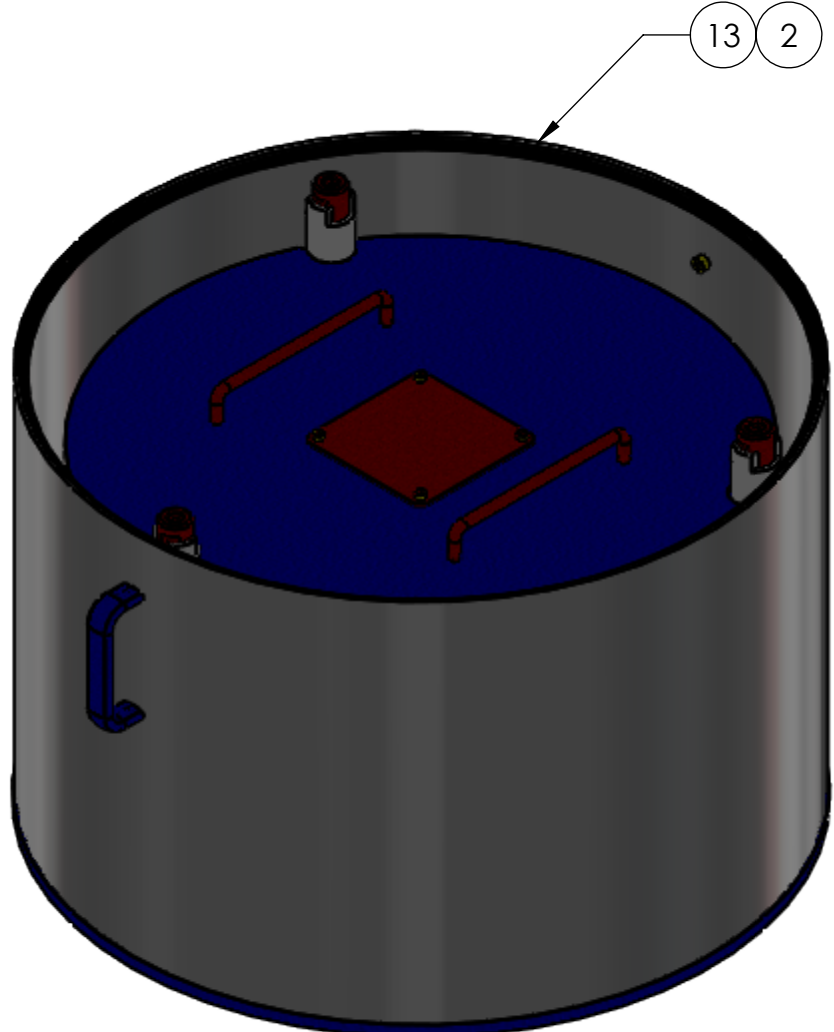

ASSY STEP 12

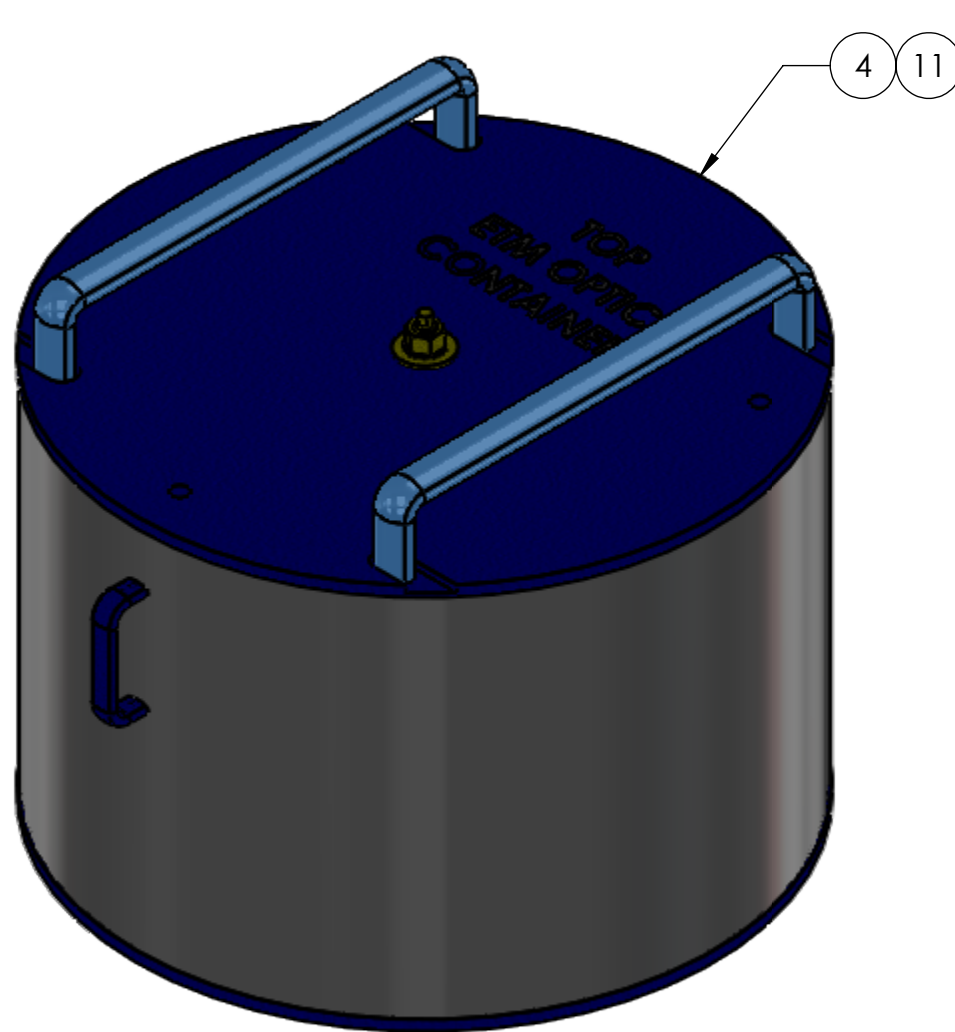

ASSY STEP 13

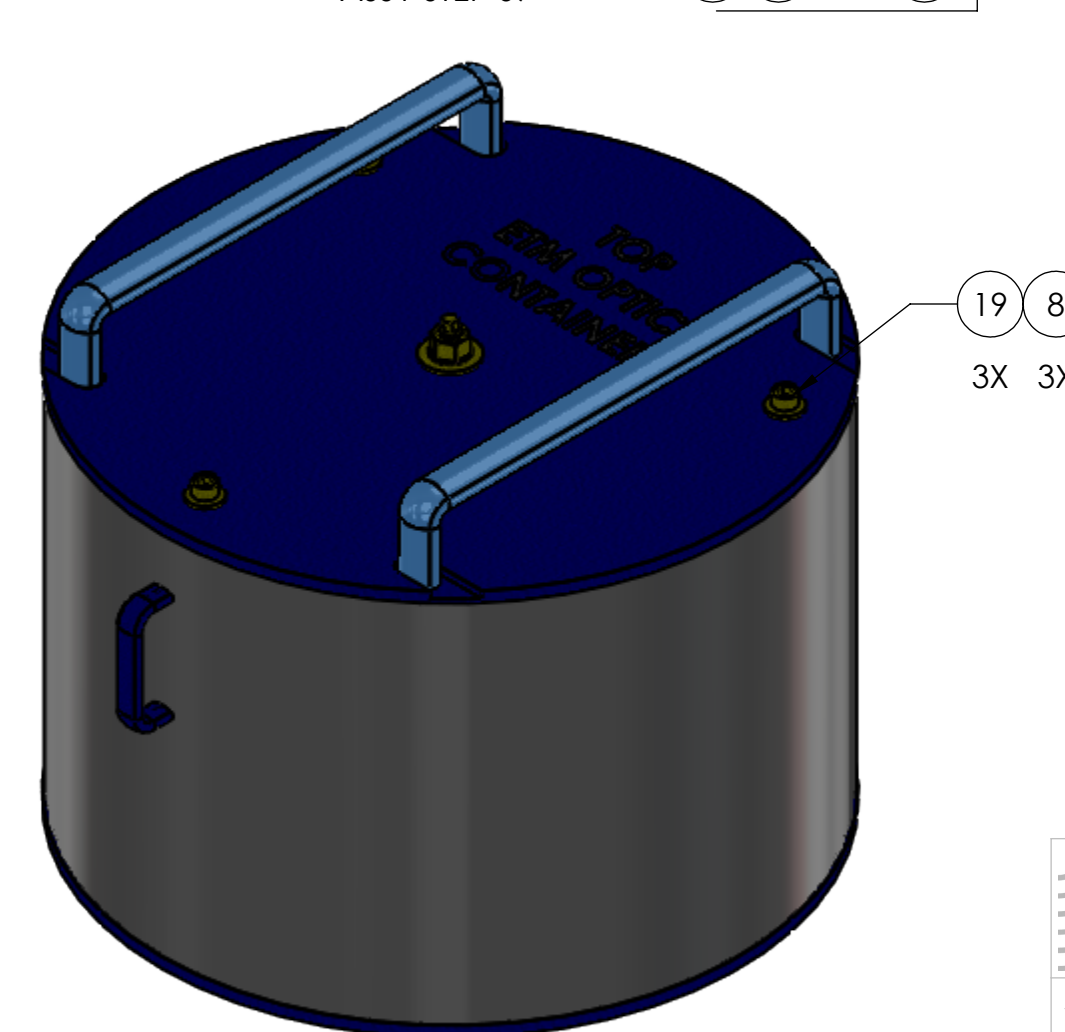

ASSY STEP 14

<b>LIGO</b> CALIFORNIA INSTITUTE OF TECHNOLOGY MASSACHUSETTS INSTITUTE OF TECHNOLOGY		REV.
SIZE	DWG. NO.	v4
<b>C</b>	D0902146	
SCALE: 1:4	PROJECTION:	SHEET 4 OF 5

# FIXTURING OPTIONS FOR MICROSCOPY, ABSORPTION SCANNING, AND OTHER OPERATIONS REQUIRING ACCESS TO S1

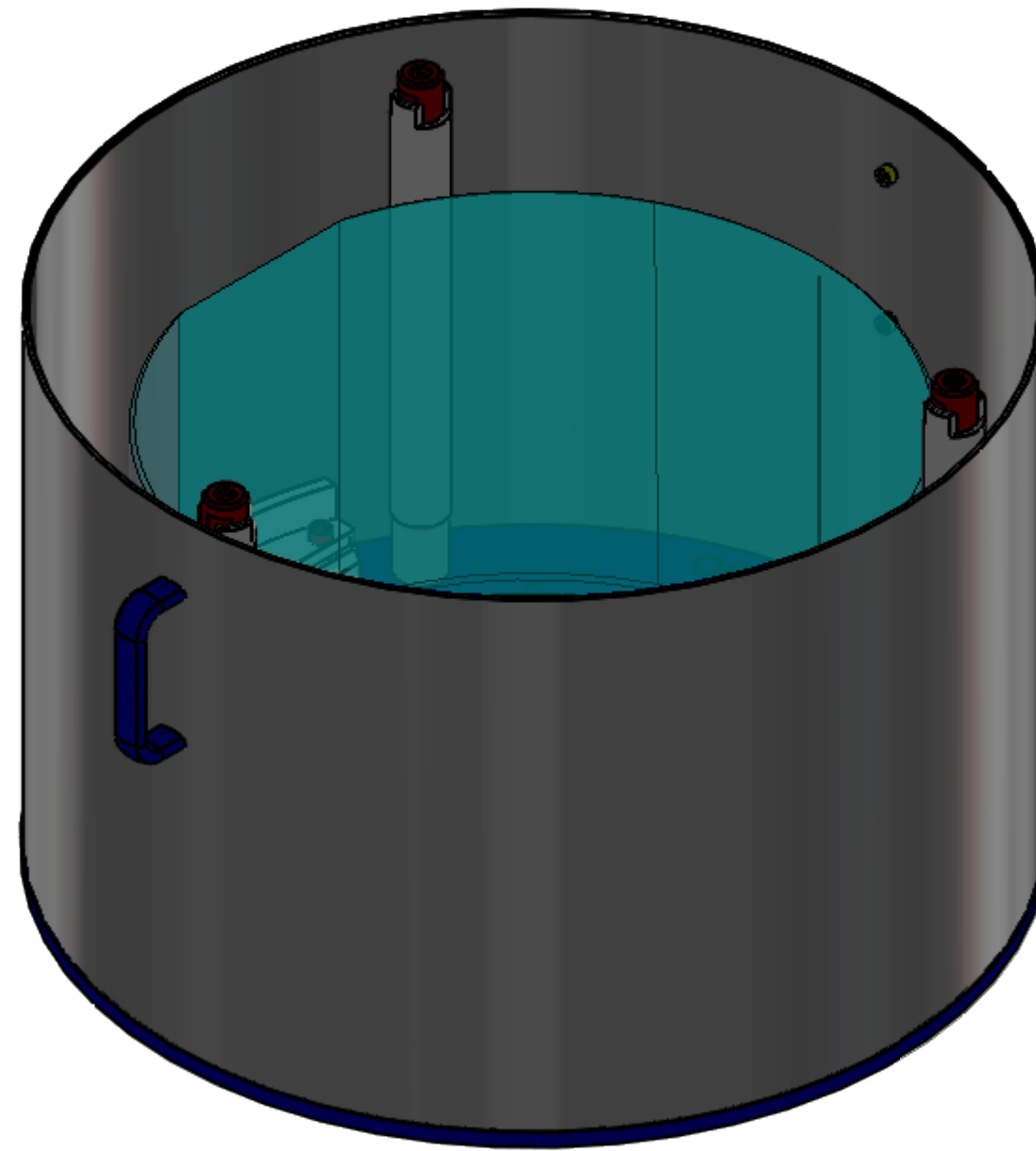

OUTER SLEEVE ON, STANDOFFS AND BLOCKS PRESENT

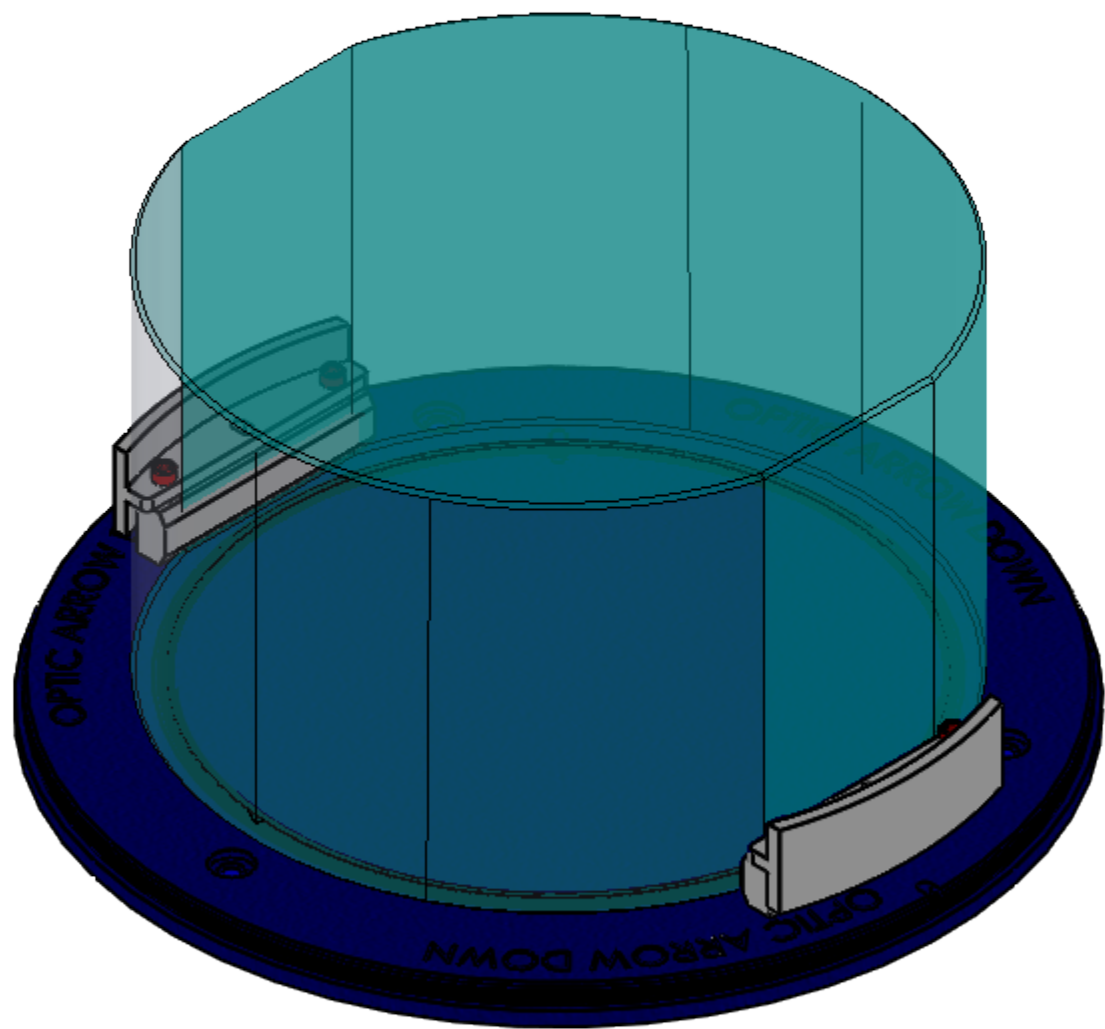

BLOCKS ONLY

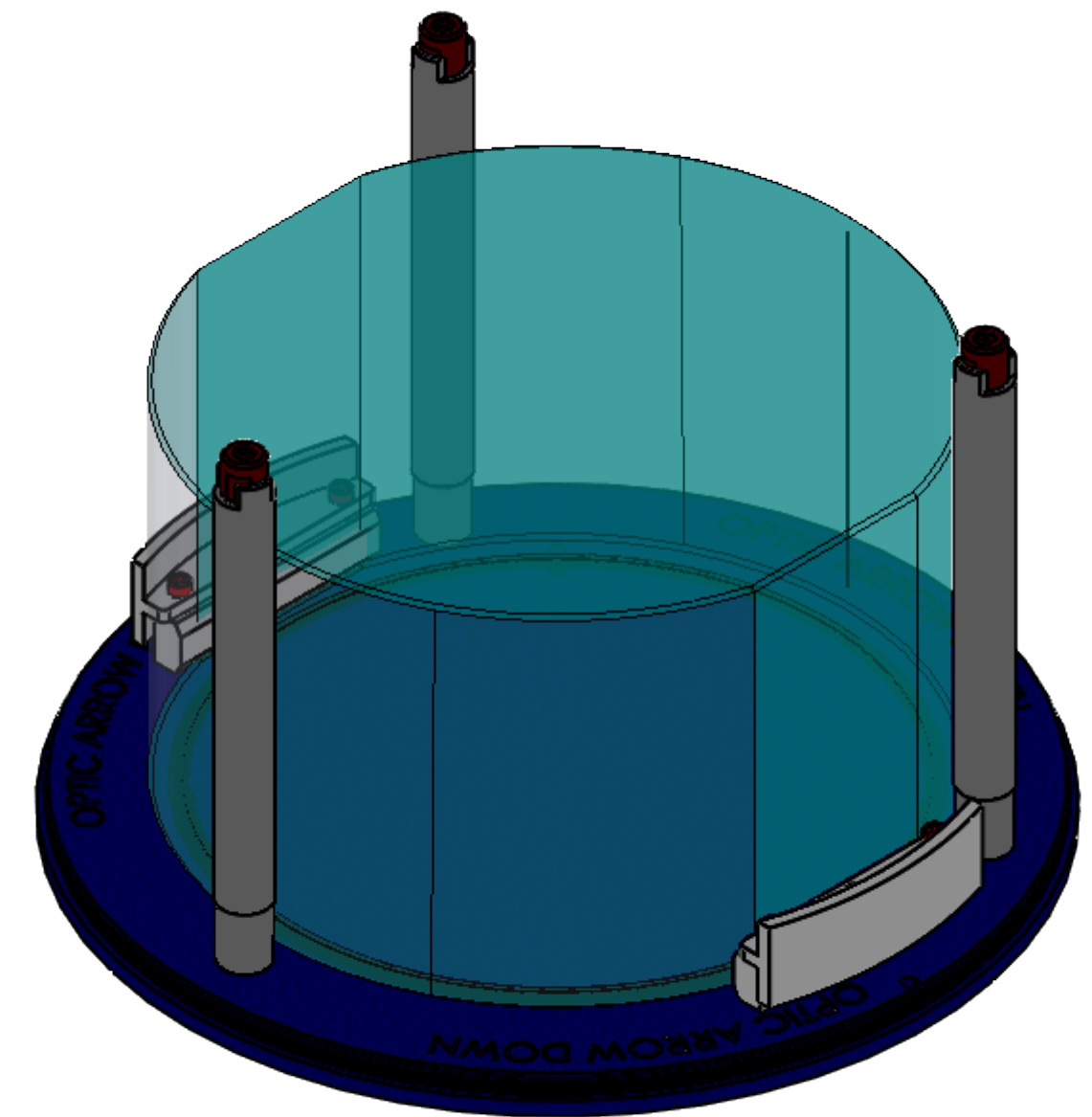

STANDOFFS AND BLOCKS PRESENT

 <b>CALIFORNIA INSTITUTE OF TECHNOLOGY</b> <b>MASSACHUSETTS INSTITUTE OF TECHNOLOGY</b>		
SIZE	DWG. NO.	REV.
<b>C</b>	D0902146	<b>v4</b>
SCALE: 1:3	PROJECTION:	SHEET 5 OF 5