

NOTES CONTINUED:

① HELICOILS TO BE INSTALLED INTO ITEM NO. 1 BY LIGO PRIOR TO ASSEMBLY AND AFTER ALL PARTS ARE CLEANED AND BAKED.

REV.	DATE	DCN #	DRAWING TREE #
v1	09 JUN 2010	E0900498	E0900353
v2	20 JUN 2011	E1100590	E0900353
-	-	-	-

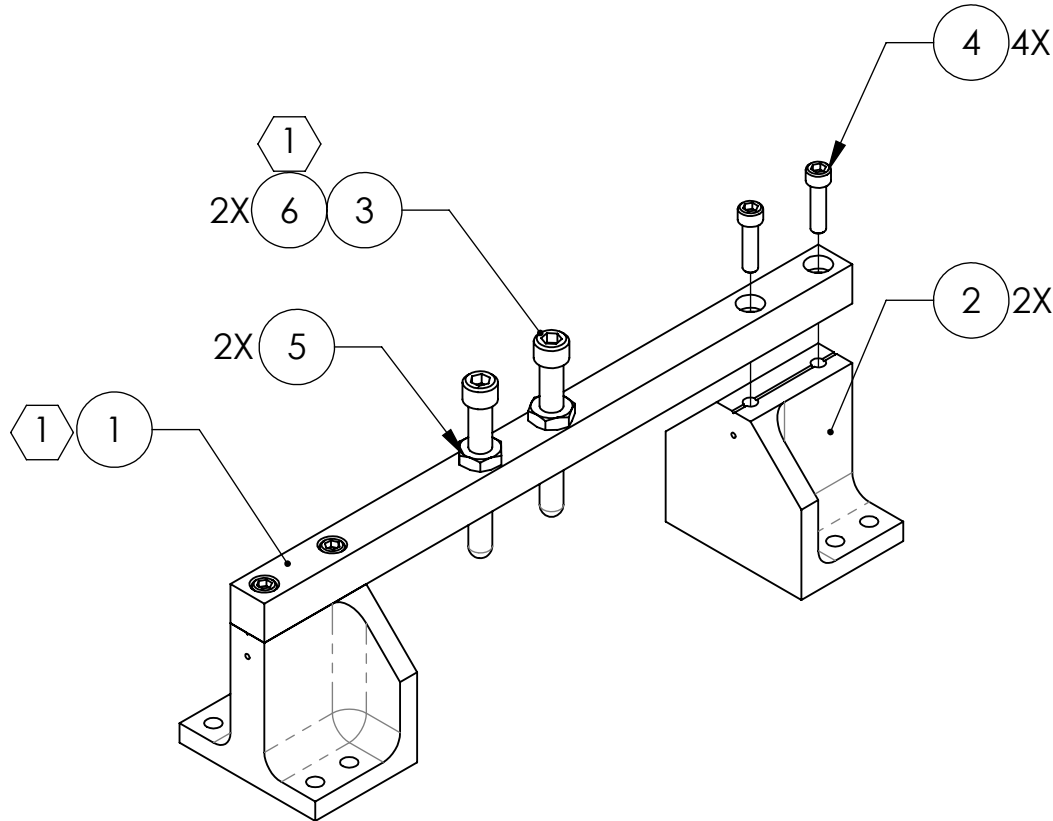

6	1185-4EN375	HELICOIL, 1/4-20 X 0.375 LONG ①	NITRONIC 60	2	1	3
5	-	JAM NUT, 1/4-20	300 SSSL	2	1	3
4	-	SCREW, SOCKET HEAD CAP, #8-32 UNC-2A X 0.625 LONG	300 SSSL	4	1	5
3	D0900999	SCREW, SOCKET HEAD CAP, 1/4-20 UNC-3A X 2 LONG, FULLY THREADED, ROUNDED END	300 SSSL	2	1	3
2	D0901936	BLADE GUARD RISER, HSTS	6061-T6 Al	2	-	2
1	D0901935	BLADE GUARD CROSSBEAM ①	6061-T6 Al	1	-	1
ITEM NO.	PART NUMBER	DESCRIPTION	MATERIAL	REQ	SPARE	TOTAL

PARTS LIST

CALIFORNIA INSTITUTE OF TECHNOLOGY MASSACHUSETTS INSTITUTE OF TECHNOLOGY		PART NAME				TOP BLADE GUARD ASSEMBLY, HSTS	
SYSTEM	ADVANCED LIGO	SUB-SYSTEM	SUS	DESIGNER	W. RASCH	01 SEP 2009	SIZE DWG. NO.
NEXT ASSY	D020700			DRAFTER	B. MOORE	11 JUN 2012	A D0901934
				CHECKER	D. BRIDGES	11 JUN 2012	v2
				APPROVAL			SCALE: 1:2 PROJECTION:
							SHEET 1 OF 1