

TEMP VIEW CREATED FOR LAYOUT OF STRUTS

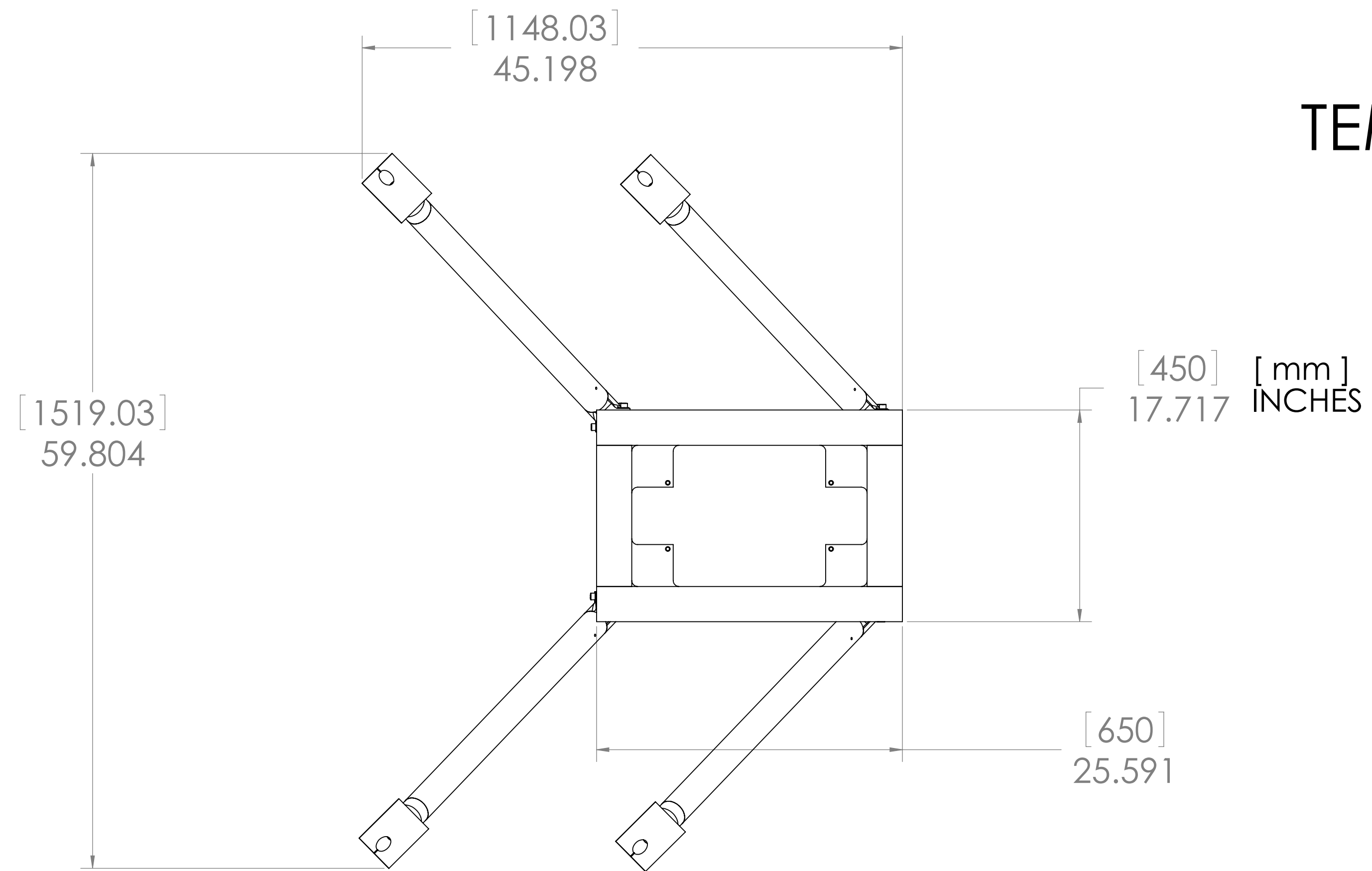

PROPRIETARY AND CONFIDENTIAL
THE INFORMATION CONTAINED IN THIS
DRAWING IS THE SOLE PROPERTY OF
-INSERT COMPANY NAME HERE-. ANY
REPRODUCTION IN PART OR AS A WHOLE
WITHOUT THE WRITTEN PERMISSION OF
-INSERT COMPANY NAME HERE- IS
PROHIBITED.

UNLESS OTHERWISE SPECIFIED:		DRAWN	NAME	DATE
DIMENSIONS ARE IN INCHES		CHECKED		
TOLERANCES:		TITLE:		
FRACTIONAL ±		DRAWN BY:		
ANGULAR MATCH ±		CHECKED BY:		
BEND ±		DATE:		
TWO PLACE DECIMAL ±		G.A.:		
THREE PLACE DECIMAL ±		COMMENTS:		
INTERPRET GEOMETRIC TOLERANCING PER:				
MATERIAL		N/A		
FINISH		N/A		
NEXT ASSY	USED ON	SIZE DWG. NO. REV		
APPLICATION		D D080501-KB 1		
		SCALE: 1:8 WEIGHT: 107.167 SHEET 1 OF 1		

REV
D080501-KB
D