

D0901576_AdvLIGO_FMP_Foil Holder Assembly, PART PDM REV: X-006, DRAWING PDM REV: X-004

REV.	DATE	DCN #	DRAWING TREE #
v1	19 AUG 2009	E0900254	-
-	-	-	-
-	-	-	-

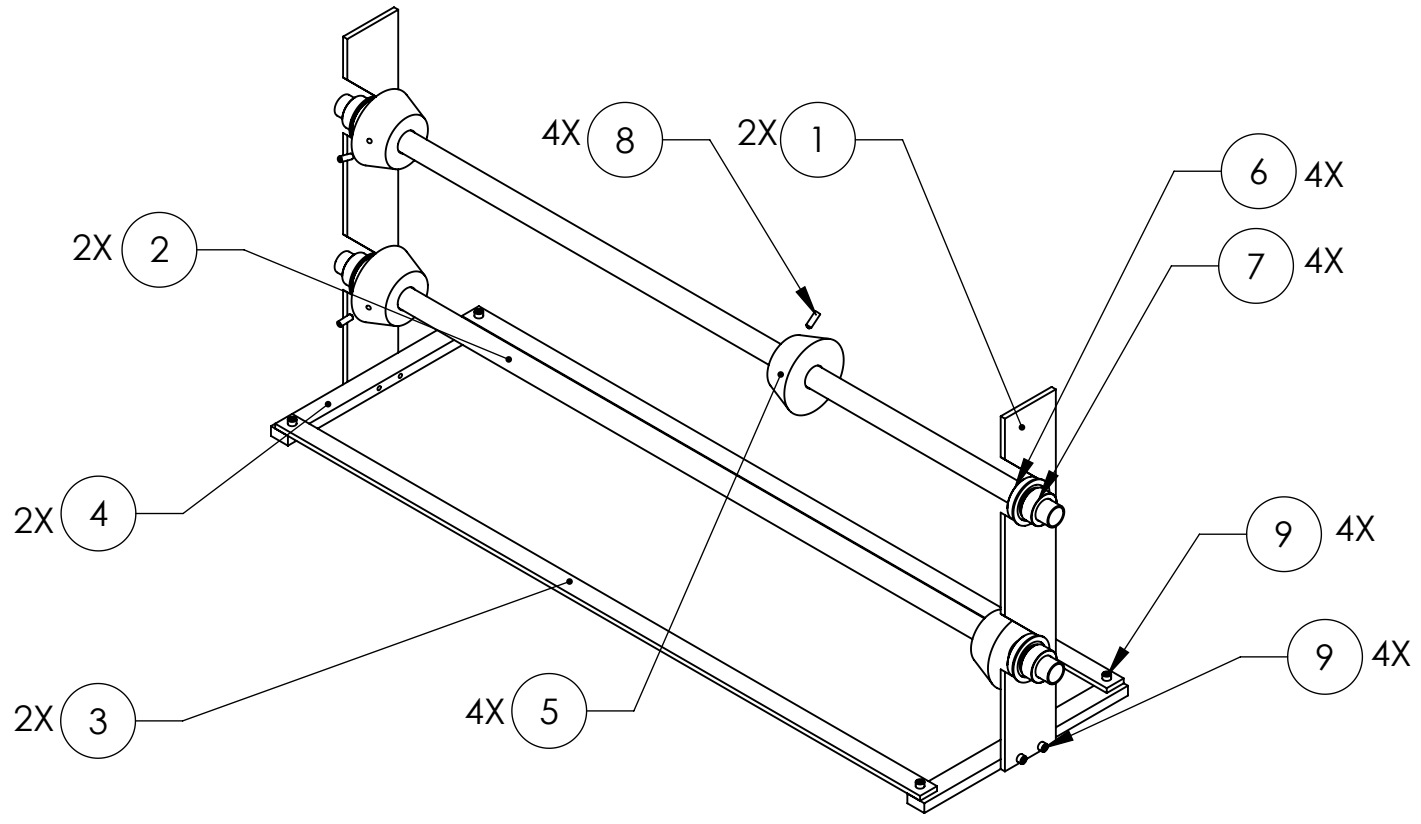

9	-	SCREW, SOCKET HEAD CAP, 1/4-20 UNC-2A X 0.75 LONG	300 SSTL	8	2	10
8	-	SCREW, SOCKET SET, 1/4-20 UNC-2A X 0.75 LONG	300 SSTL	4	1	5
7	9946K240	COLLAR, SHAFT (MCMaster-CARR P/N)	ALUMINUM	4	-	4
6	6384K373	BEARING, ROLLER (MCMaster-CARR P/N)	STEEL	4	-	4
5	D0901785	FOIL HOLDER ROLL STOP	6061-T6 Al	4	-	4
4	D0901572	FOIL HOLDER BASE PLATE	6061-T6 Al	2	-	2
3	D0901574	HORIZONTAL SUPPORT	6061-T6 Al	2	-	2
2	D0901575	FOIL HOLDER ROD	6061-T6 Al	2	-	2
1	D0901573	VERTICAL SUPPORT	6061-T6 Al	2	-	2

ITEM NO.	PART NUMBER	DESCRIPTION	MATERIAL	REQ	SPARE	TOTAL
PARTS LIST						
CALIFORNIA INSTITUTE OF TECHNOLOGY MASSACHUSETTS INSTITUTE OF TECHNOLOGY		PART NAME FOIL HOLDER ASSEMBLY				
SYSTEM	ADVANCED LIGO	SUB-SYSTEM	FMP	DESIGNER	M. MEYER	03 AUG 2009
				DRAFTER	W. RASCH	20 AUG 2009
				CHECKER	M. MEYER	20 AUG 2009
				APPROVAL		
NEXT ASSY	TOP LEVEL		SIZE	DWG. NO.		REV.
			B	D0901576		v1
			SCALE: 1:8	PROJECTION:	SHEET 1 OF 1	