

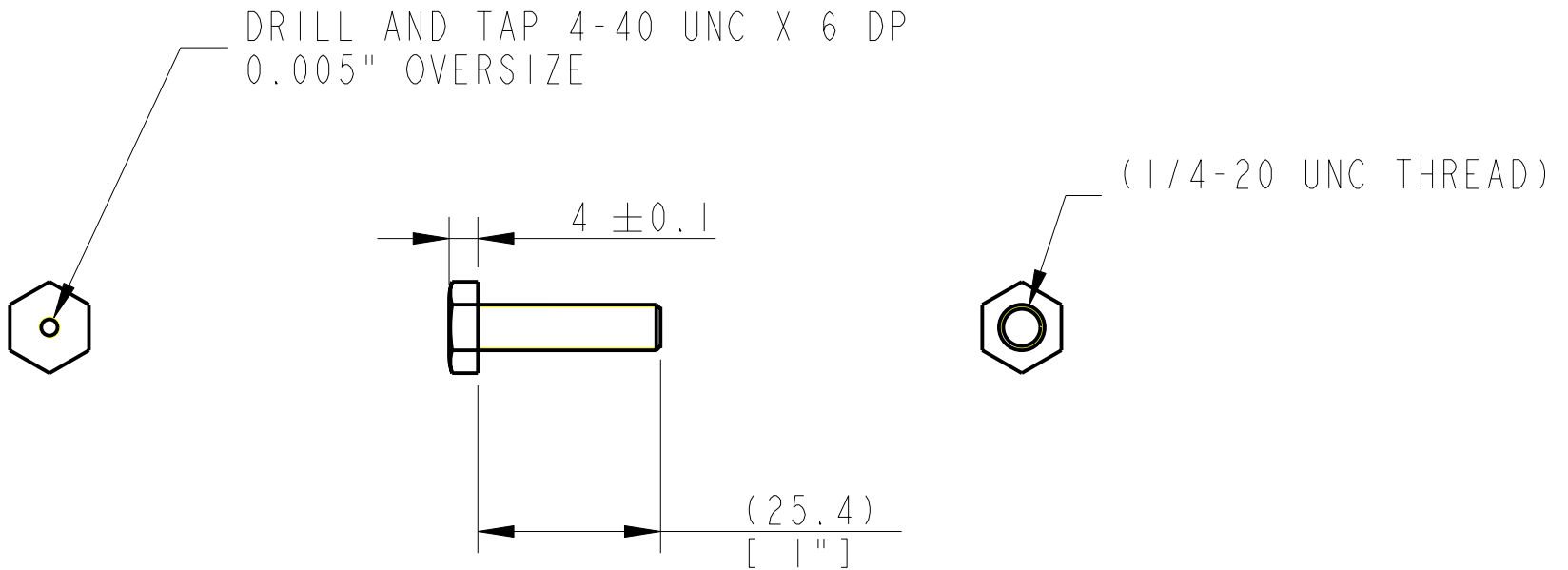

REV.	DATE	DCN #	DRAWING TREE #



NOTE:

USE A STANDARD HEX HEAD 1/4-20 UNC BOLT, AND MAKE SPECIFIED MODIFICATIONS

DRAWING UNCHECKED AND FOR REFERENCE ONLY

NOTES: (UNLESS OTHERWISE SPECIFIED)		 CALIFORNIA INSTITUTE OF TECHNOLOGY MASSACHUSETTS INSTITUTE OF TECHNOLOGY IGR, GLASGOW UNIVERSITY GEO 600 GROUP RUTHERFORD APPLETON LABORATORIES												
1. REMOVE ALL SHARP EDGES, R.02 MIN. 2. DO NOT SCALE FROM DRAWING. 3. ALL MACHINING FLUIDS SHALL BE WATER SOLUBLE AND FREE OF SULFUR, CHLORINE AND SILICONE, SUCH AS CINCINNATI MILACRON'S CIMTECH 410 (STAINLESS STEEL) 4. SCRIBE, ENGRAVE OR STAMP DRAWING PARTNUMBER ON NOTED SURFACE OF PART AND A THREE DIGIT SERIAL NUMBER. SERIAL NUMBERS START AT 001 FOR THE FIRST PART AND PROCEED CONSECUTIVELY. USE .07" HIGH CHARACTERS. EXAMPLE: D020188- 001. A VIBRATORY TOOL MAY BE USED.	DIMENSIONS ARE IN mm [INCHES] TOLERANCES: X.XX ± 0.2 mm ° ANGULAR ± 0.25 °		SYSTEM <b>aLIGO</b>											
	MATERIAL: ST. STEEL 304 OR 316		SUB-SYSTEM <b>SUS</b>											
	FINISH: CLEAN, GREASE FREE √μm [μin] Ra = 1.6		NEXT ASSY <b>QUAD</b>											
	<table border="1"> <thead> <tr> <th></th> <th>NAME</th> <th>DATE</th> </tr> </thead> <tbody> <tr> <td>DRAWN</td> <td>J O'DELL</td> <td>24/APR/08</td> </tr> <tr> <td>CHECKED</td> <td>MB</td> <td>15/MAR/10</td> </tr> <tr> <td>APPROVED</td> <td>JOD</td> <td>15/MAR/10</td> </tr> </tbody> </table>			NAME	DATE	DRAWN	J O'DELL	24/APR/08	CHECKED	MB	15/MAR/10	APPROVED	JOD	15/MAR/10
	NAME	DATE												
DRAWN	J O'DELL	24/APR/08												
CHECKED	MB	15/MAR/10												
APPROVED	JOD	15/MAR/10												
<table border="1"> <tr> <td>SIZE <b>A</b></td> <td>DRG. NO. <b>D080242</b></td> <td>REV <b>F.</b></td> </tr> </table>		SIZE <b>A</b>	DRG. NO. <b>D080242</b>	REV <b>F.</b>	SCALE 1:1	PROJECTION: 	SHEET 1 OF 1							
SIZE <b>A</b>	DRG. NO. <b>D080242</b>	REV <b>F.</b>												