

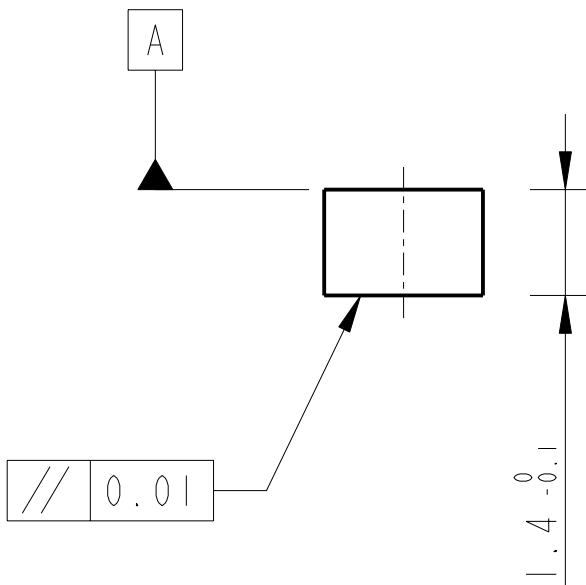

REV.	DATE	DCN #	DRAWING TREE #

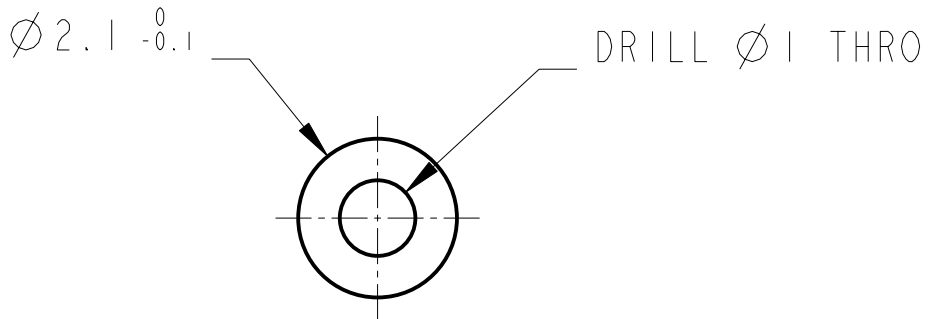

NOTES: (UNLESS OTHERWISE SPECIFIED)		 CALIFORNIA INSTITUTE OF TECHNOLOGY MASSACHUSETTS INSTITUTE OF TECHNOLOGY IGR, GLASGOW UNIVERSITY GEO 600 GROUP RUTHERFORD APPLETON LABORATORIES	
1. REMOVE ALL SHARP EDGES, R.02 MIN. 2. DO NOT SCALE FROM DRAWING. 3. ALL MACHINING FLUIDS SHALL BE WATER SOLUBLE AND FREE OF SULFUR, CHLORINE AND SILICONE, SUCH AS CINCINNATI MILACRON'S CIMTECH 410 (STAINLESS STEEL) 4. SCRIBE, ENGRAVE OR STAMP DRAWING PARTNUMBER ON NOTED SURFACE OF PART AND A THREE DIGIT SERIAL NUMBER. SERIAL NUMBERS START AT 001 FOR THE FIRST PART AND PROCEED CONSECUTIVELY. USE .07" HIGH CHARACTERS. EXAMPLE: D020188- 001. A VIBRATORY TOOL MAY BE USED.	DIMENSIONS ARE IN mm [INCHES] TOLERANCES:		SYSTEM ADVANCED LIGO
	X.XX ±0.2 mm ANGULAR ±0.25 °		SUB-SYSTEM SUS
	MATERIAL: ST. STEEL 416 - MAGNETIC		NEXT ASSY PEN RE MASS MAGNETS
	FINISH: CLEAN √μm [μin] Ra = 1.6		PART NAME STEEL DISK (EXTERNAL SHIELDED MAGNETS)
	NAME	DATE	SIZE A
	DRAWN J O'DELL	10/OCT/08	DRG. NO. D070238
	CHECKED IW	10/OCT/08	REV E
	APPROVED IW	10/OCT/08	SCALE 10: PROJECTION:  SHEET 1 OF 1