

2 HOLES 1/4-20 UNC
TAPPED THRO' 0.005"
OVERSIZE, C'BORE $\varnothing 10$
X 7 DP $\varnothing 0.2$

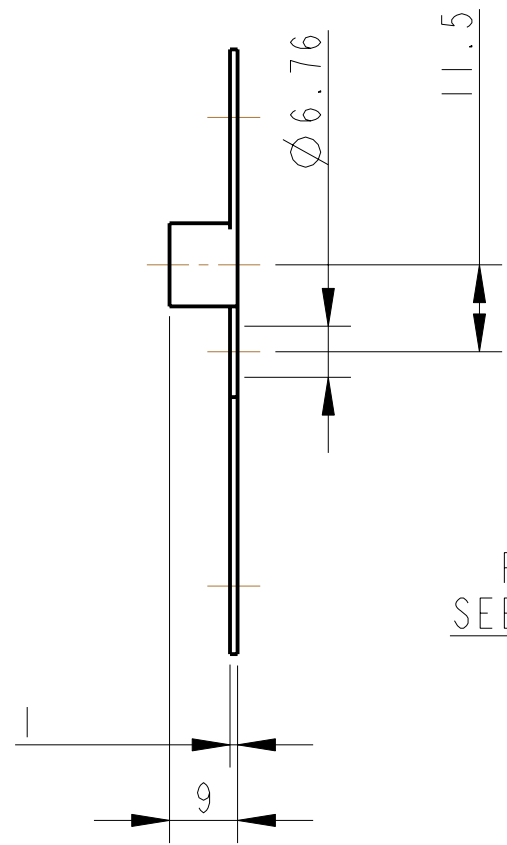

PART NO.
SEE NOTE 4

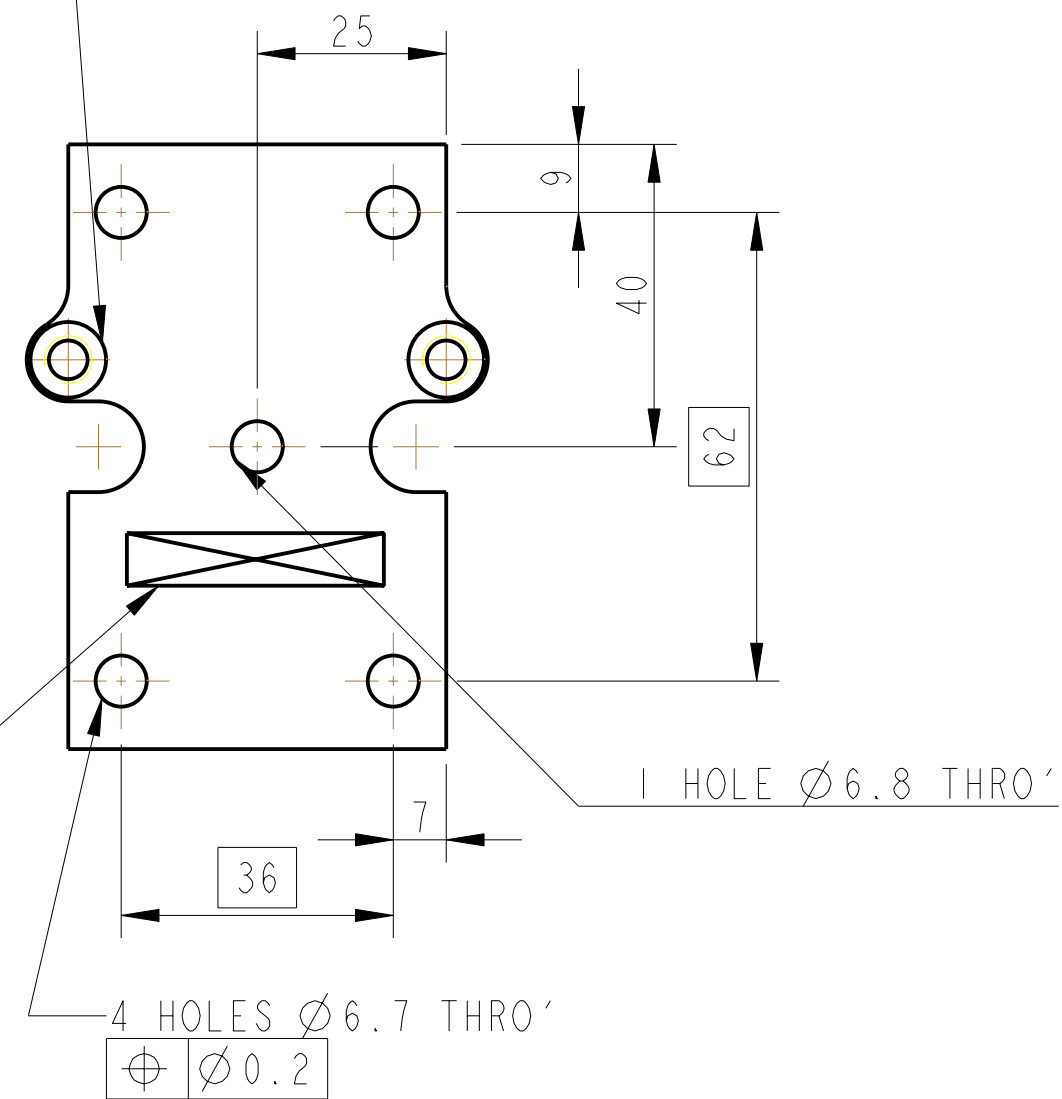

NOTES: (UNLESS OTHERWISE SPECIFIED)

- REMOVE ALL SHARP EDGES, R.02 MIN.
- DO NOT SCALE FROM DRAWING.
- ALL MACHINING FLUIDS SHALL BE WATER SOLUBLE AND FREE OF SULFUR, CHLORINE AND SILICONE, SUCH AS CINCINNATI MILACRON'S CIMTECH 410 (STAINLESS STEEL)
- SCRIBE, ENGRAVE OR STAMP DRAWING PART NUMBER ON NOTED SURFACE OF PART AND A THREE DIGIT SERIAL NUMBER. SERIAL NUMBERS START AT 001 FOR THE FIRST PART AND PROCEED CONSECUTIVELY. USE .07" HIGH CHARACTERS. EXAMPLE: D020188- 001. A VIBRATORY TOOL MAY BE USED.

DIMENSIONS ARE IN mm [INCHES]	
TOLERANCES:	
X.XX ± 0.2 mm	
ANGULAR $\pm 0.25^\circ$	
MATERIAL: AL ALLOY 5083 OR SIMILAR	
FINISH: CLEAN AND DEGREASED	
$\sqrt{\mu m}$ [μin] Ra = 1.6	
NAME	DATE
DRAWN I WILMUT	14/Jun/07
CHECKED MB	15/MAR/10
APPROVED JOD	15/MAR/10

CALIFORNIA INSTITUTE OF TECHNOLOGY MASSACHUSETTS INSTITUTE OF TECHNOLOGY IGR, GLASGOW UNIVERSITY GEO 600 GROUP RUTHERFORD APPLETON LABORATORIES	
SYSTEM	aLIGO
SUB-SYSTEM	SUS
NEXT ASSY	QUAD WIREING HARNESS
PART NAME	UIM MASS TOP WIRE CLAMP
SIZE	B
DRG. NO.	D070220
SCALE	1:1
PROJECTION	1st Angle
SHEET	1 OF 1