

D070218 ALIGO, SUS, QUAD WIRING HARNESS, MASS WIRE CLAMP, PART PDM REV: X-017, DRAWING PDM REV: X-000

REV.	DATE	DCN #	DRAWING TREE #
B	26 JUN 2010	-	-
v3	23 JAN 2012	E1200066-x0	-
-	-	-	-

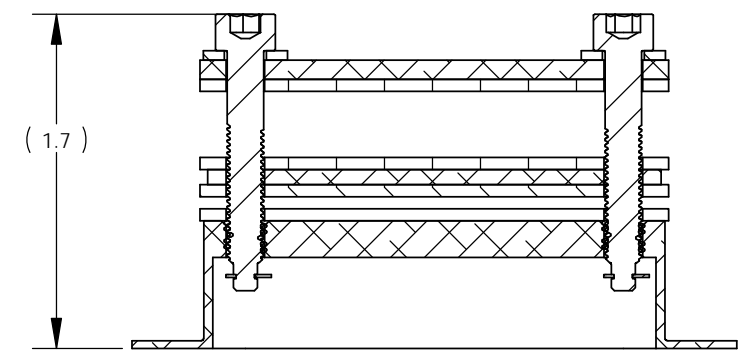

SECTION B-B

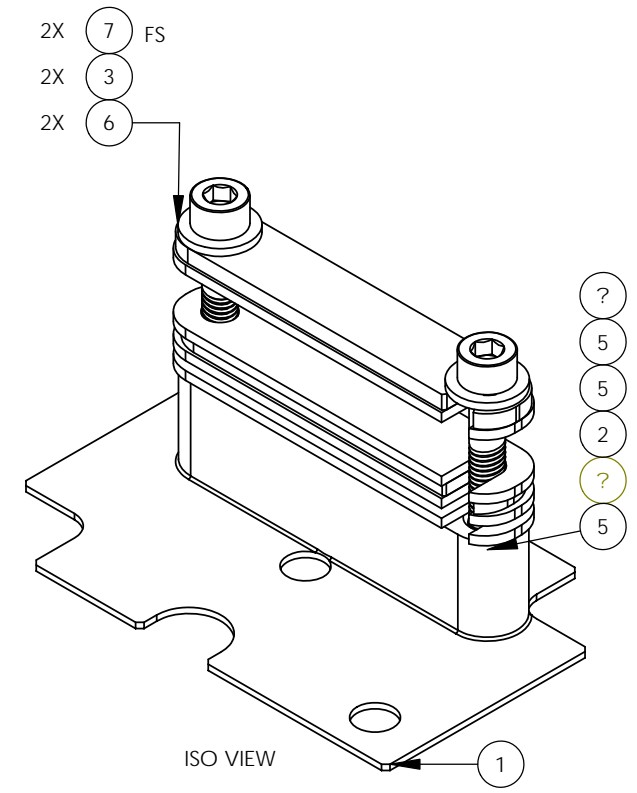
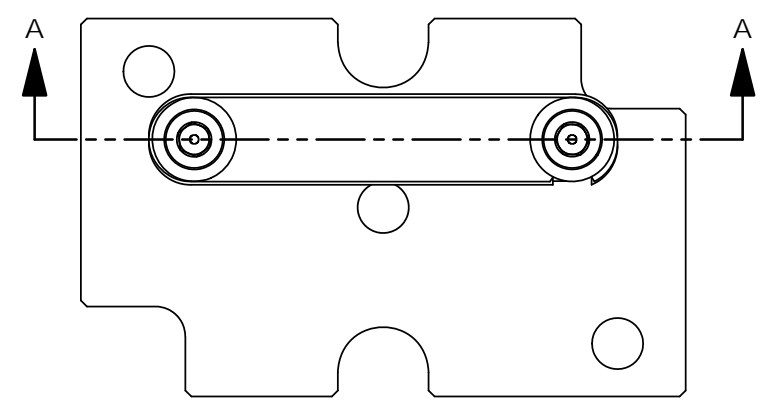
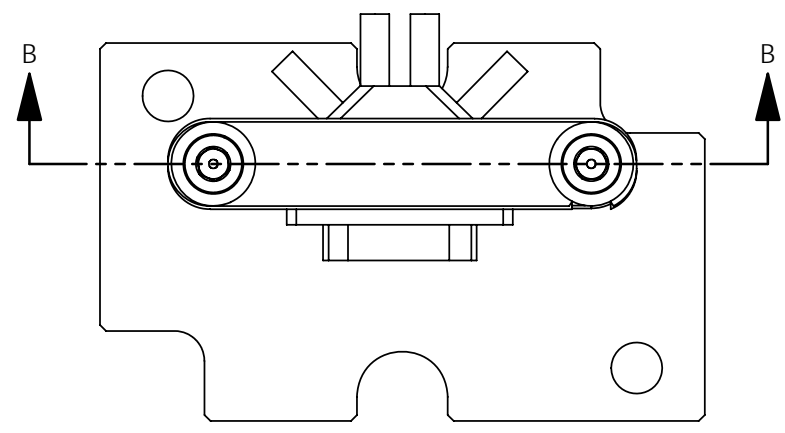
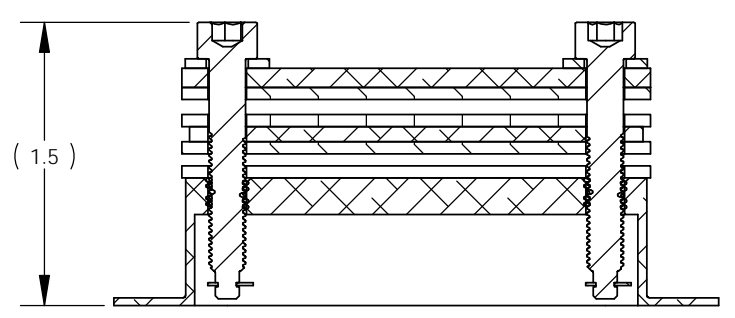

SECTION A-A
(FULLY COMPRESSED)

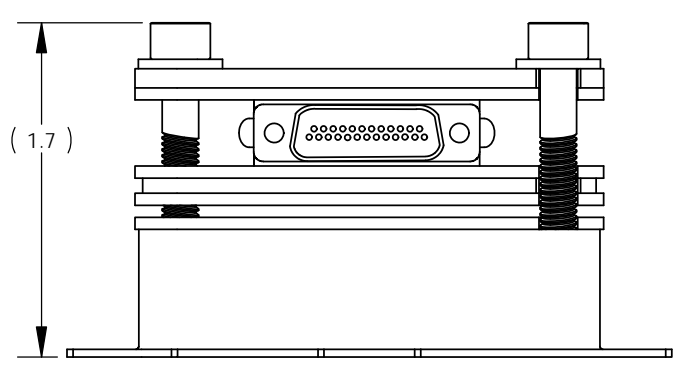

WITH CONNECTOR
(CONNECTOR NOT PART OF FINISHED ASSY. SHOWN FOR REF. ONLY)

ITEM NO.	PART NUMBER	DESCRIPTION	QTY.
7	94981A120 McMASTER-CARR	RETAINING RING, 1/8 SHAFT, TYPE E, SIDE MT.	2
6	MS15795-808	WASHER, FLAT, #10	2
5	D1102147	ALIGO SUS, CABLE CLAMP FLOUREL PAD, OSEM/ECD (REDESIGNED)	4
4	D1102136	ALIGO, SUS, QUAD WIRING HARNESS, OSEM/ESD CABLE CLAMP JAW (REDESIGNED)	1
3	D1102135	ALIGO, SUS, QUAD, SCREW, SHC, 10-32 X 1.25 LG., OSEM/ESD CABLE CLAMP	2
2	D1102134	ALIGO, SUS, QUAD, CABLE CLAMP DIVIDER SHIM OSEM/ESD (REDESIGNED)	1
1	D1102133	ALIGO, SUS, QUAD NPTYPE WIRING HARNESS, MASS WIRE CLAMP ASSY.	1

PARTS LIST

NOTES AND TOLERANCES: (UNLESS OTHERWISE SPECIFIED)				LIGO		PART NAME	
				CALIFORNIA INSTITUTE OF TECHNOLOGY MASSACHUSETTS INSTITUTE OF TECHNOLOGY		ALIGO, SUS, QUAD, WIRING HARNESS, MASS WIRE CLAMP	
MATERIAL		FINISH		NEXT ASSY		SIZE DWG. NO.	
N/A		N/A μinch		MULTIPLE		B D070218	
				DESIGNER		REVISION	
				I1WILMUT		14 JUN 2007	
				CHECKER		15 MAR 2010	
				APPROVAL		15 MAR 2010	
				SCALE: 1:1		PROJECTION:	
						SHEET 1 OF 1	