

FIRST ANGLE PROJECTION

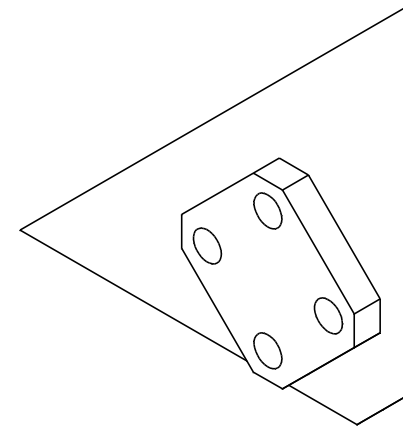
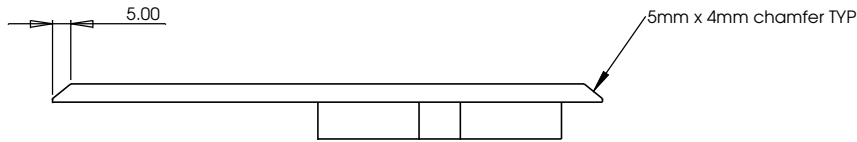
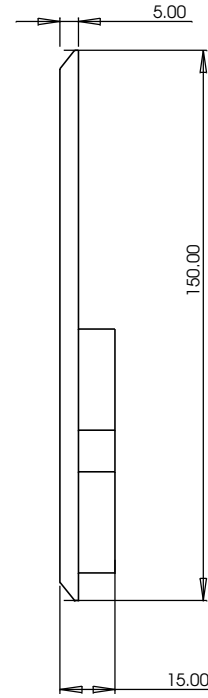
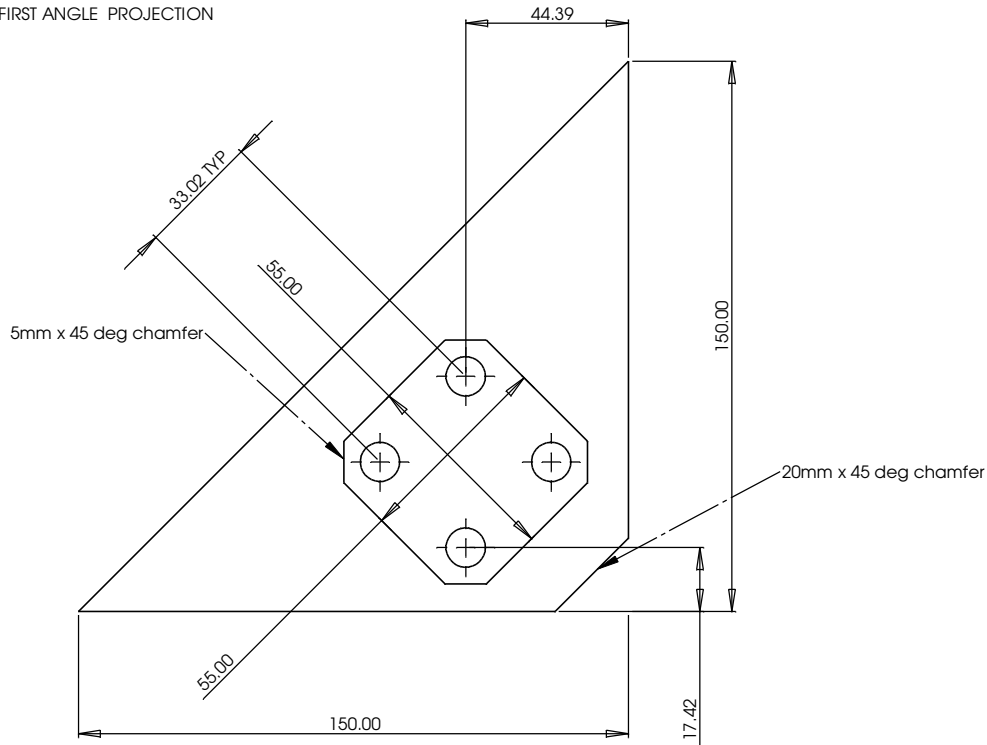

ITEM No 7

NOTES: (UNLESS OTHERWISE SPECIFIED)			PARTS LIST		
1. DO NOT SCALE FROM DRAWING. 2. REMOVE ALL SHARP EDGES, R.02 MAX. 3. ALL MACHINING FLUIDS SHALL BE WATER SOLUBLE AND FREE OF SULFUR, CHLORINE AND SILICONE.			DIMENSIONS ARE IN INCHES TOLERANCES: .XX ± 0.01 .XXX ± 0.005 ANGULAR ± 0.1°		
4. SCRIBE, ENGRAVE OR MECHANICALLY STAMP DRAWING (NO INKS OR DYES) PART NUMBER, REVISION, OR NOTED SURFACE OF PART FOLLOWED ON THE NEXT LINE WITH A THREE DIGIT SERIAL NUMBER. SERIAL NUMBERS START AT 001 FOR THE FIRST ARTICLE AND PROCEED CONSECUTIVELY. USE 12" HIGH CHARACTERS, UNLESS THE SIZE OF THE PART DICTATES SMALL CHARACTERS. A VIBRATORY TOOL MAY BE USED. EXAMPLE: 0 0 5 0 2 4 7 -A S/N 001			MATERIAL: ALUMINIUM ALLOY 6062 FINISH: CLEAN		
DRAWN: [ ] CHECKED: [ ] APPROVED: [ ]			PART NAME: CORNER BRACKET SIZE: DWG. NO. NTE UPPER 007 SCALE: 1:1 PROJECTION: [ ] SHEET 011		

REV.	DATE	DCN #	DRAWING TREE #