

REV.	DATE	DCN #	DRAWING TREE #
A	13/OCT/06	E060239	
B	19/DEC/07	E060239-B	

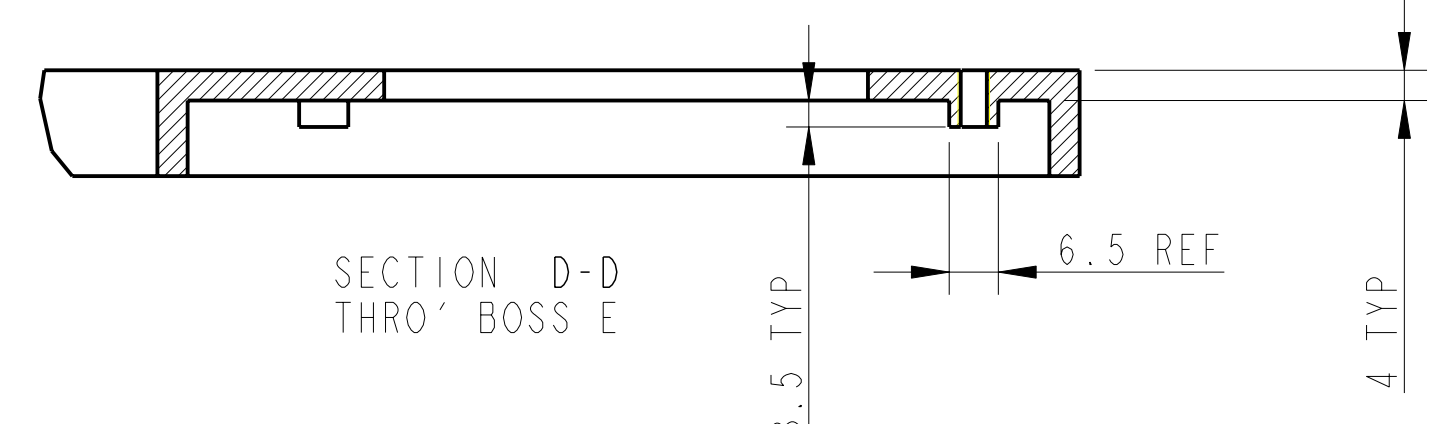

TAP FOR HELICOIL 8-32 UNC THRU'
HELICOIL NOT TO BE FITTED.

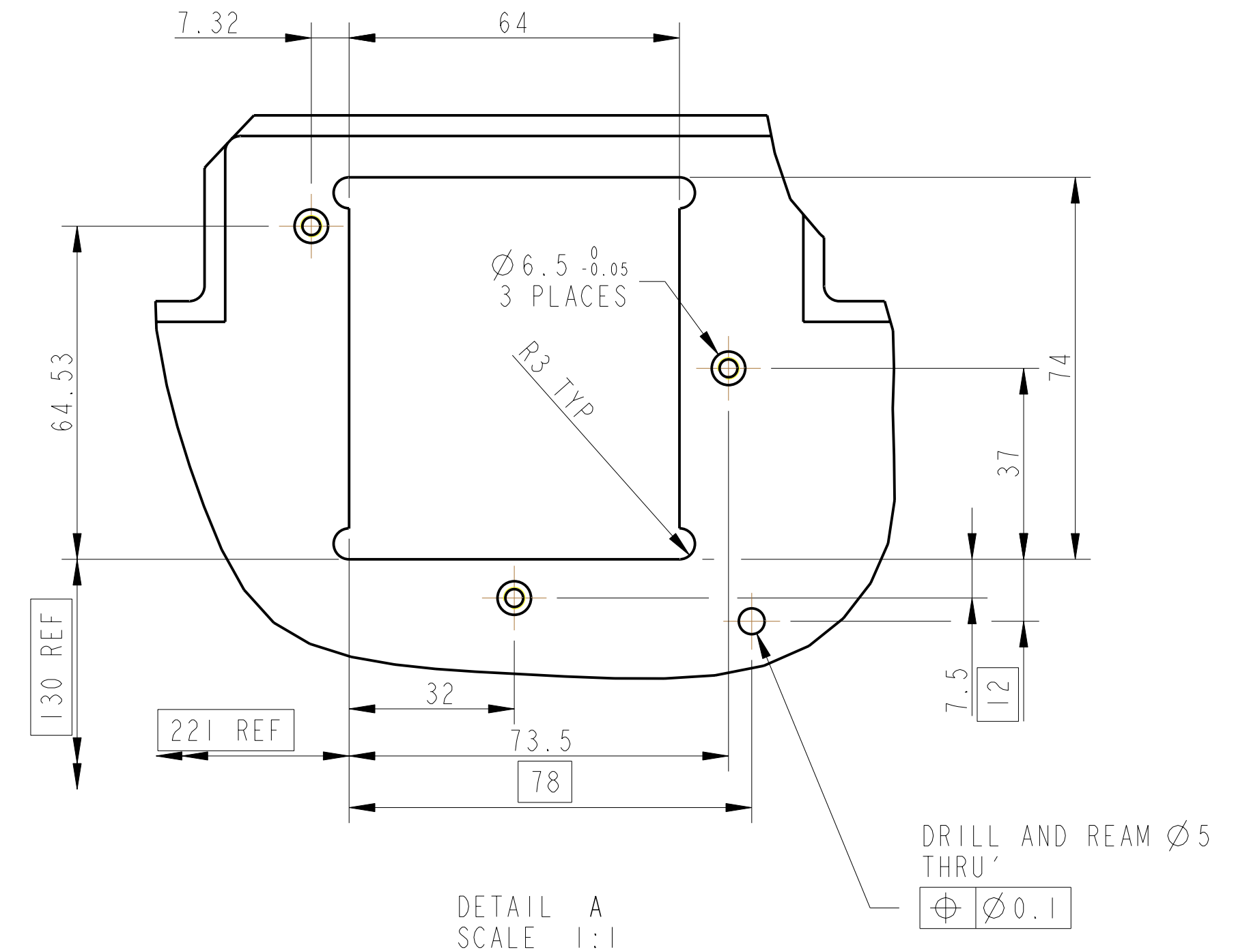
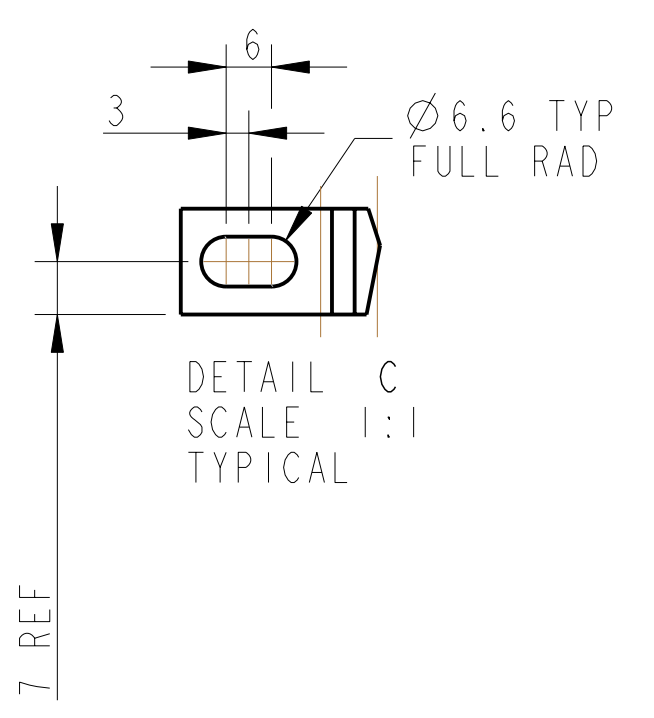
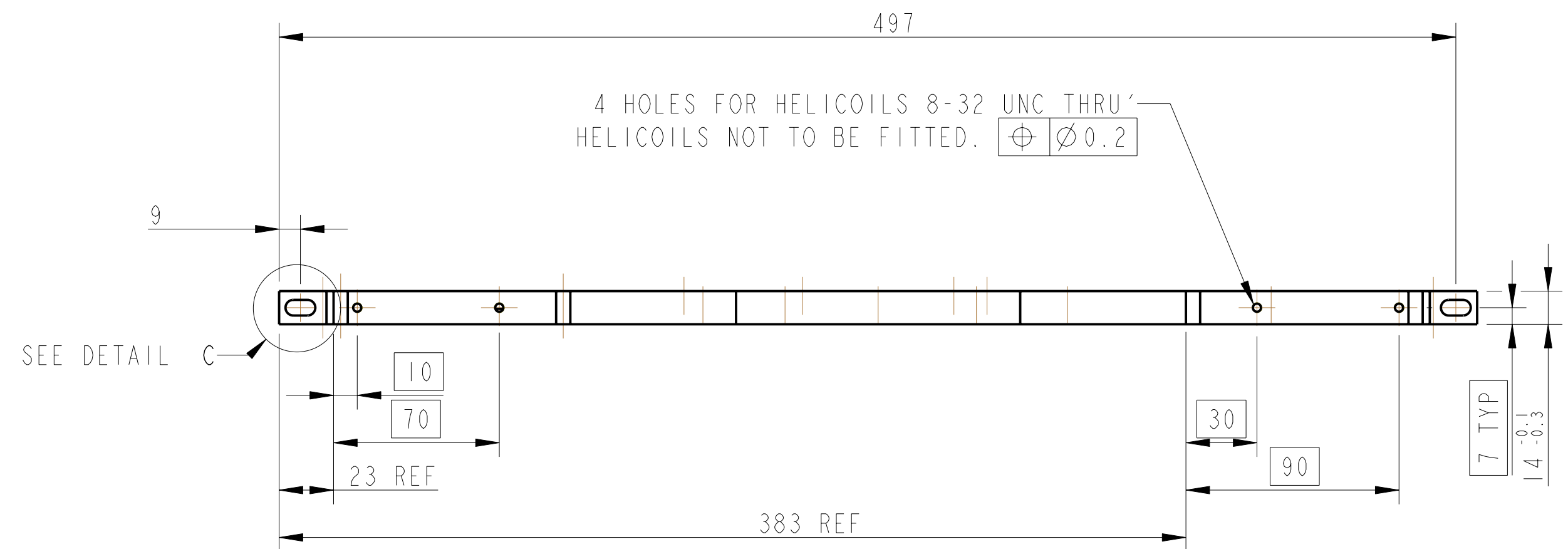
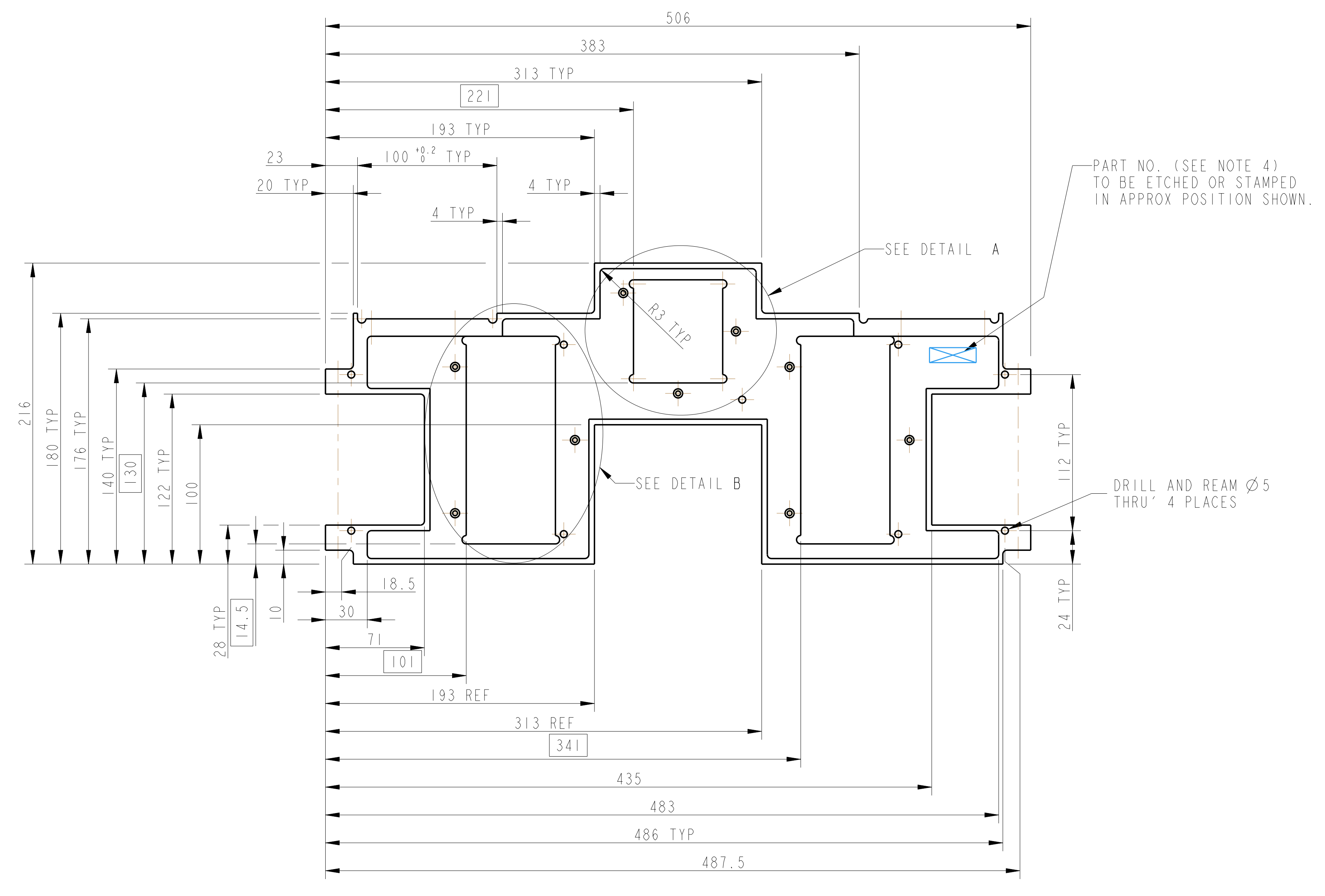
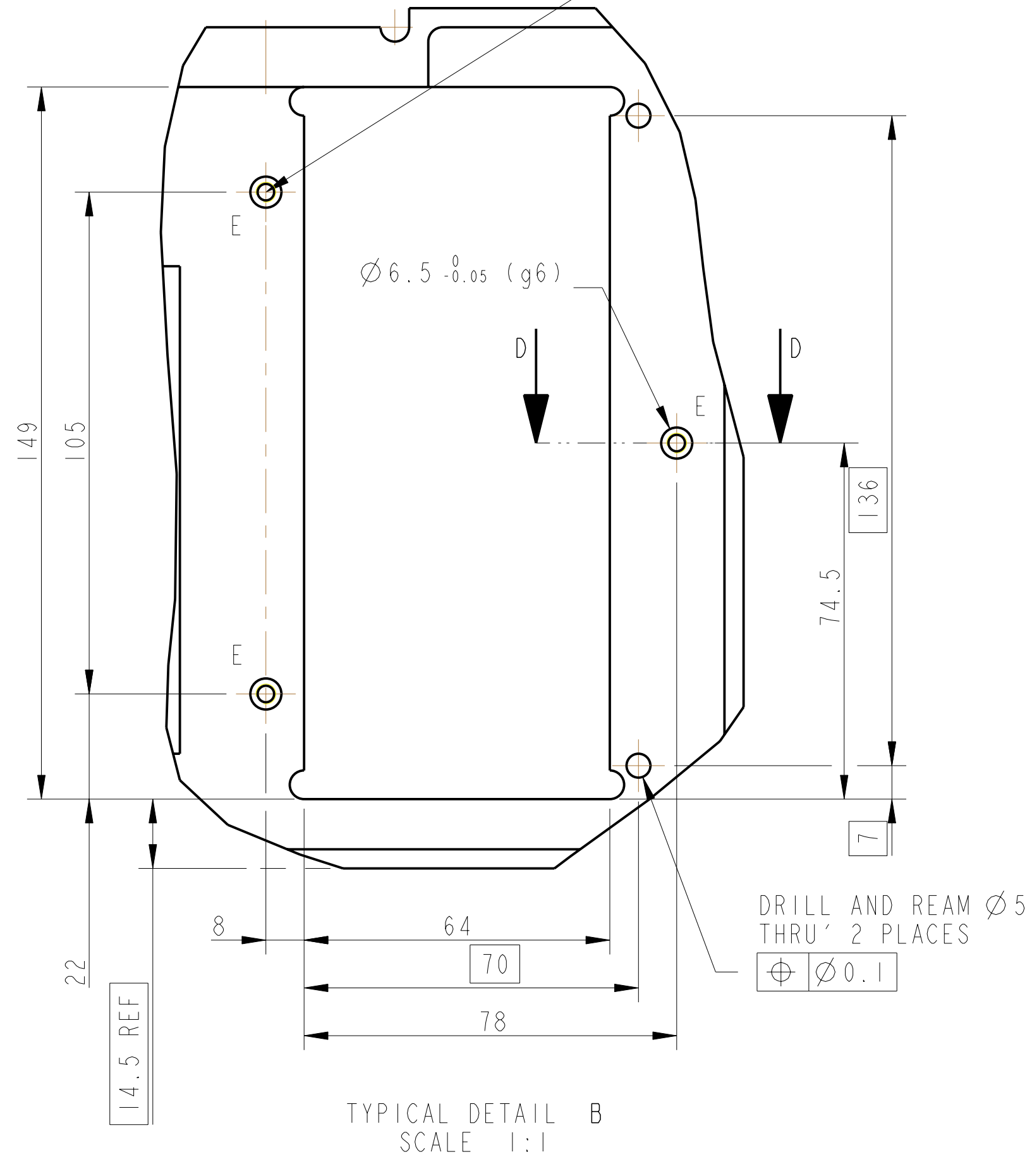

NOTES: (UNLESS OTHERWISE SPECIFIED)

- REMOVE ALL SHARP EDGES. R0.2 MIN.
- DO NOT SCALE FROM DRAWING.
- ALL MACHINING FLUIDS SHALL BE WATER SOLUBLE AND FREE OF SULFUR, CHLORINE AND SILICONE. SUCH AS CINCINNATI MILACRON'S CIMTECH 410 (STAINLESS STEEL).
- SCRIBE, ENGRAVE OR STAMP PART NUMBER ON NOTED SURFACE OF PART AND A THREE DIGIT SERIAL NUMBER. SERIAL NUMBERS START AT 001 FOR THE FIRST PART AND PROCEED CONSECUTIVELY. USE 07* HIGH CHARACTERS. EXAMPLE: D060311-001 - A VIBRATOR TOOL MAY BE USED.

DIMENSIONS ARE IN mm (INCHES) TOLERANCES:

XX ± 0.2
ANGULAR ±0.25°

MATERIAL: AL ALLOY 5053 H4

FINISH: CLEAN AND DEGREASE
Ra = 1.6

DRAWN: I WILMOT 03/10/06
CHECKED: MB 15/MAR/10
APPROVED: JOD 15/MAR/10

CALIFORNIA INSTITUTE OF TECHNOLOGY
MASSACHUSETTS INSTITUTE OF TECHNOLOGY
RUTGERS UNIVERSITY
RUTHERFORD APPLIATION LABORATORIES

SYSTEM: aLIGO
SUB-SYSTEM: SUS
NEXT ASSY: QUAD TABLECLOTH
PART NAME: FRONT AND REAR PLATE
NOISE TABLECLOTH

DRG. NO.: D060311
SCALE: 1:21 PROJECTION: SHEET 1 OF 1