

NOTES CONTINUED:
 ⑤ SCRIBE, ENGRAVE, OR MECHANICALLY STAMP (NO INKS OR DYES) DRAWING PART NUMBER AND REVISION ON NOTED SURFACE FOLLOWED ON THE NEXT LINE BY A THREE DIGIT SERIAL NUMBER. SERIAL NUMBERS START AT 001 FOR THE FIRST ARTICLE AND PROCEED CONSECUTIVELY. USE .07" HIGH CHARACTERS. EXAMPLE: DXXXXXXX-VY, S/N 001. A VIBRATORY TOOL MAY BE USED.

REV.	DATE	DCN #	DRAWING TREE #
-	07-29-2009	E0900223-v1	-
-	-	-	-
-	-	-	-

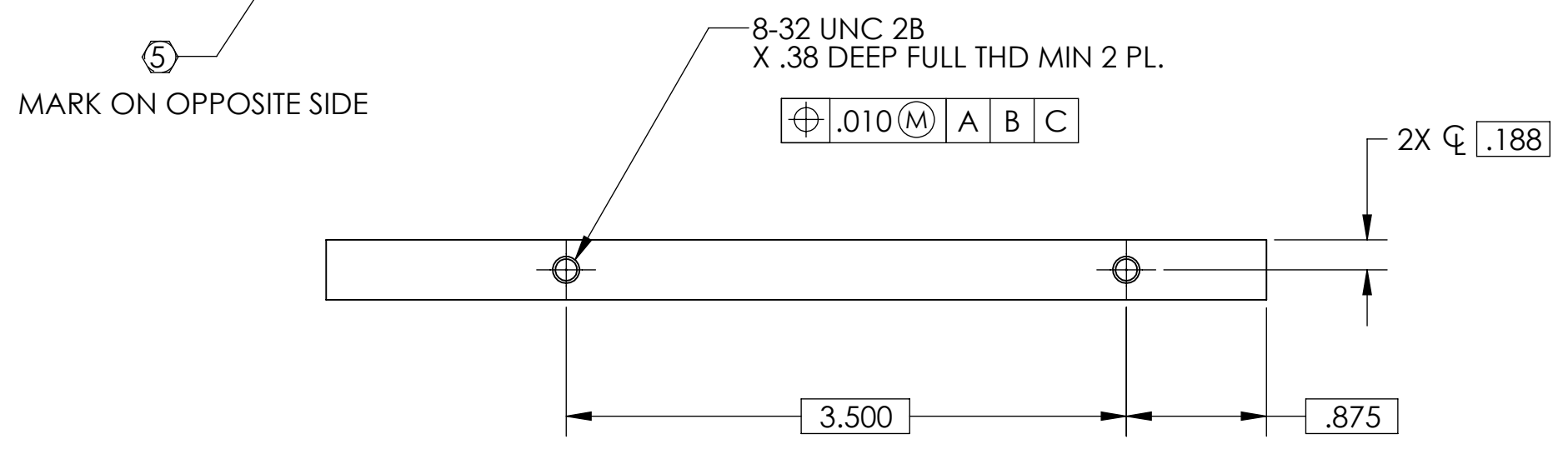
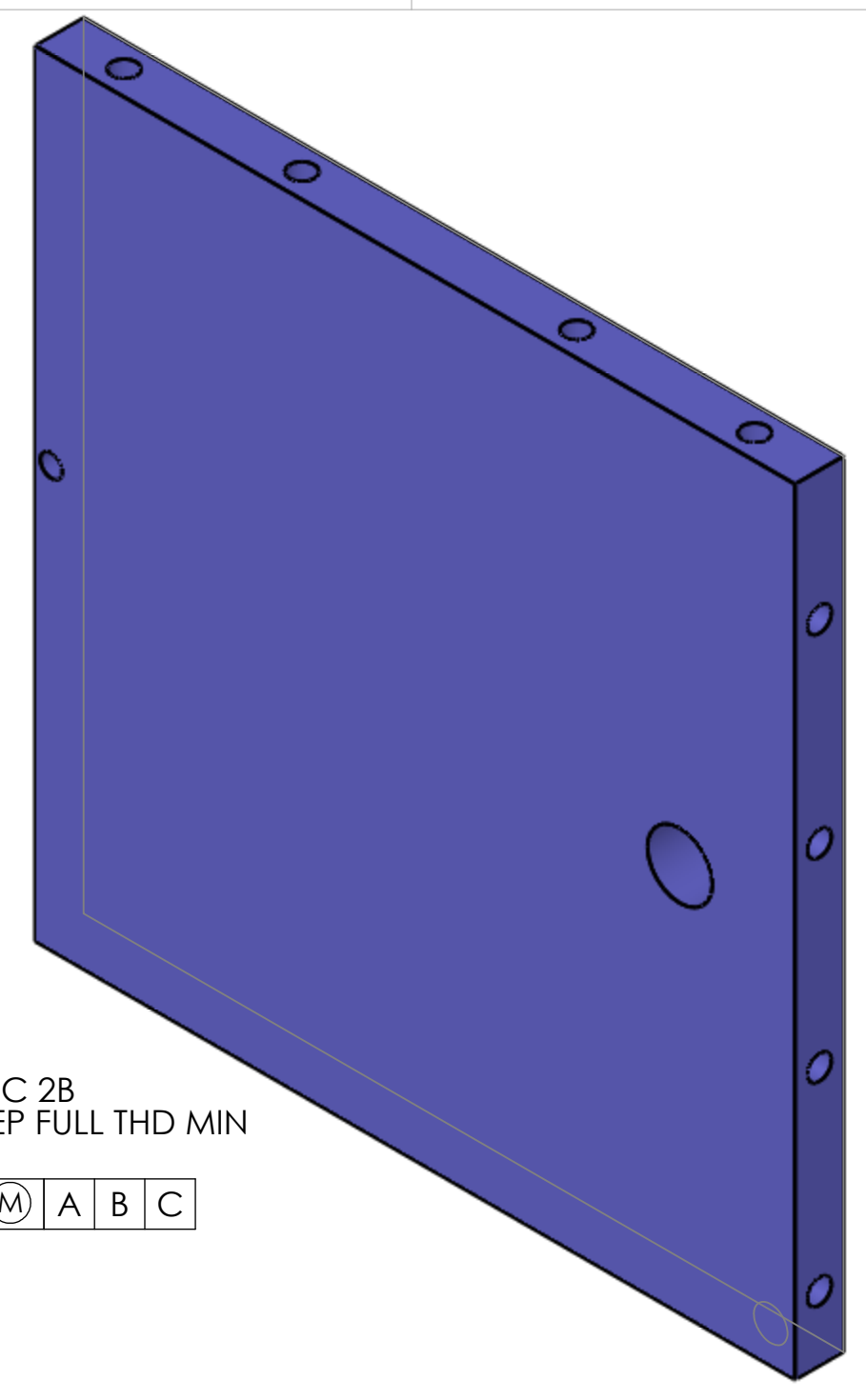
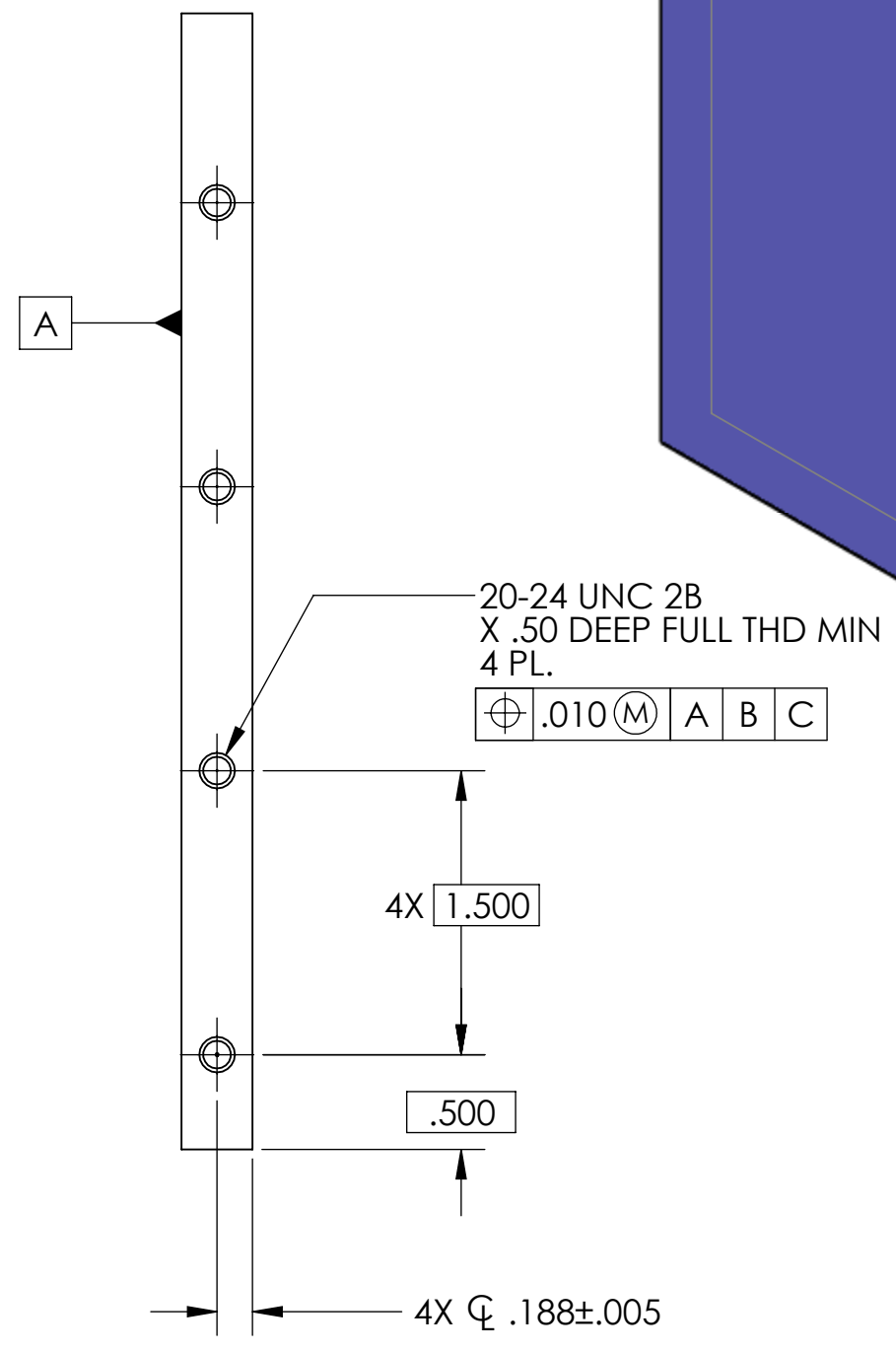
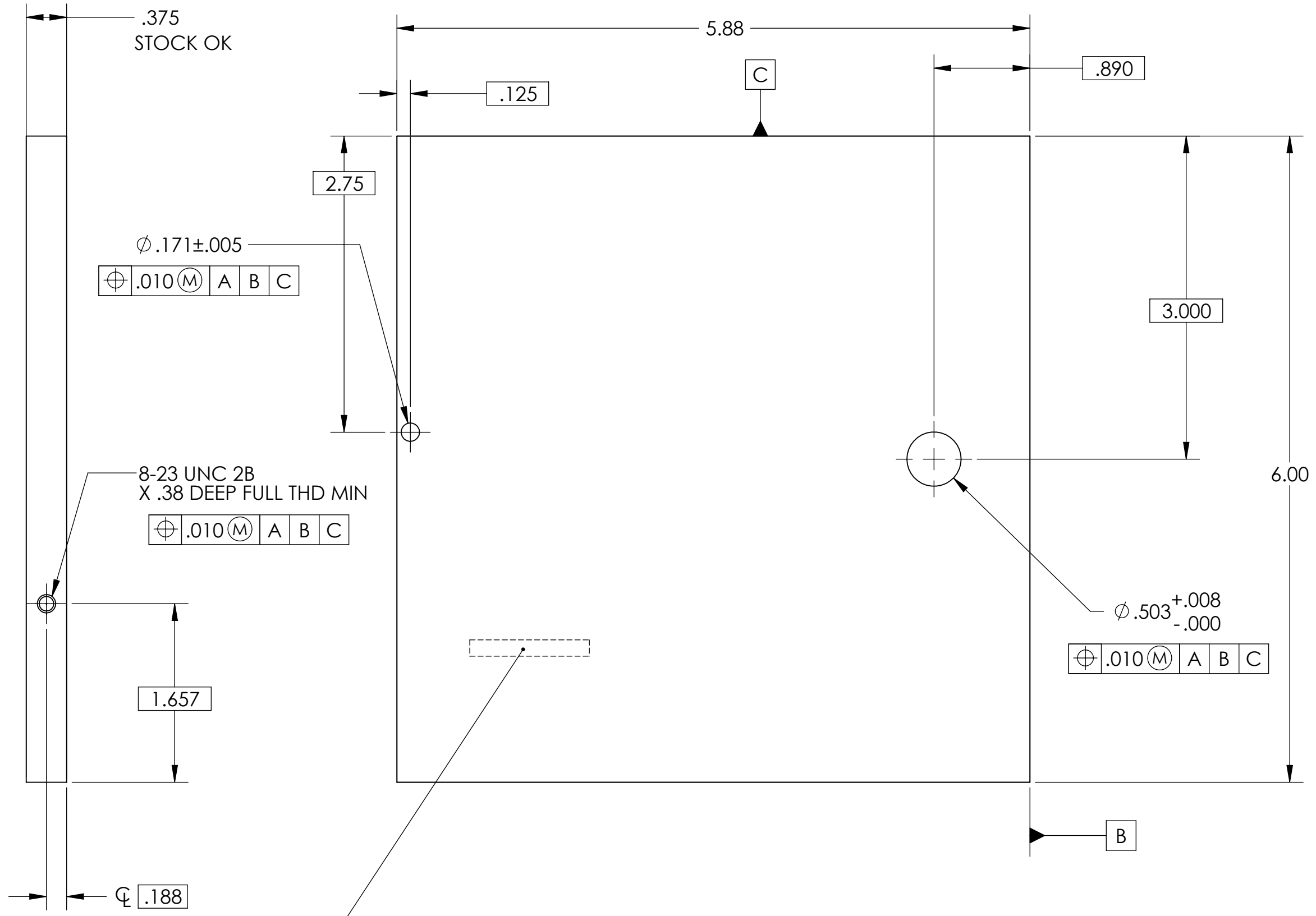
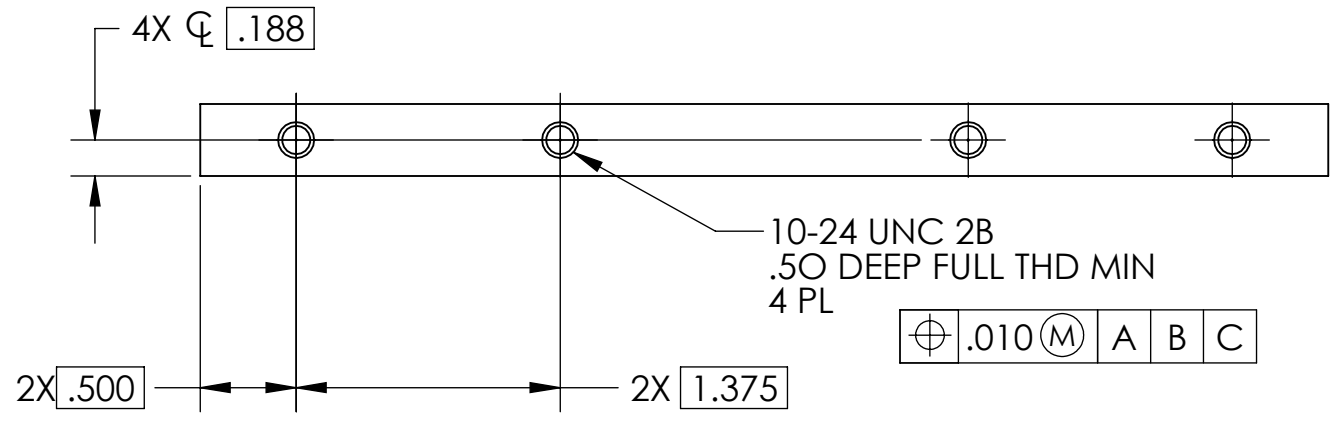

NOTES AND TOLERANCES: (UNLESS OTHERWISE SPECIFIED)

1. INTERPRET DRAWING PER ASME Y14.5-1994.
2. REMOVE ALL SHARP EDGES, R.02 MIN.
3. DO NOT SCALE FROM DRAWING.
4. ALL MACHINING FLUIDS SHALL BE WATER SOLUBLE AND FREE OF SULFUR, CHLORINE AND SILICONE, SUCH AS CINCINNATI MILACRON'S CIMTECH 410.

MATERIAL	6061-T6	FINISH	N/A
----------	---------	--------	-----

LIGO CALIFORNIA INSTITUTE OF TECHNOLOGY
 MASSACHUSETTS INSTITUTE OF TECHNOLOGY

SYSTEM: **ADVANCED LIGO** SUB-SYSTEM: **AOS**

NEXT ASSY: **D0901417**

PART NAME: **ADLIGO_TCS_LASER_ENCLOSURE_OPP_APERTURE**

DESIGNER	KMAILAND	07-15-2009	SIZE	DWG. NO.	REV.
DRAFTER	KMAILAND	07-19-2009	c	D0901424	v1
CHECKER			SCALE: 1:1	PROJECTION:	SHEET 1 OF 1
APPROVAL					

TOLERANCES:
 .XX ± .02
 .XXX ± .005

ANGULAR ± 1.0°