

NOTES CONTINUED:

⑤ SCRIBE, ENGRAVE, OR MECHANICALLY STAMP (NO INKS OR DYES) DRAWING PART NUMBER AND REVISION ON NOTED SURFACE FOLLOWED ON THE NEXT LINE BY A THREE DIGIT SERIAL NUMBER. SERIAL NUMBERS START AT 001 FOR THE FIRST ARTICLE AND PROCEED CONSECUTIVELY. USE .07" HIGH CHARACTERS. EXAMPLE: DXXXXXXX-VY, S/N 001. A VIBRATORY TOOL MAY BE USED.

⑥ MACHINE ALL SURFACES.

REV.	DATE	DCN #	DRAWING TREE #

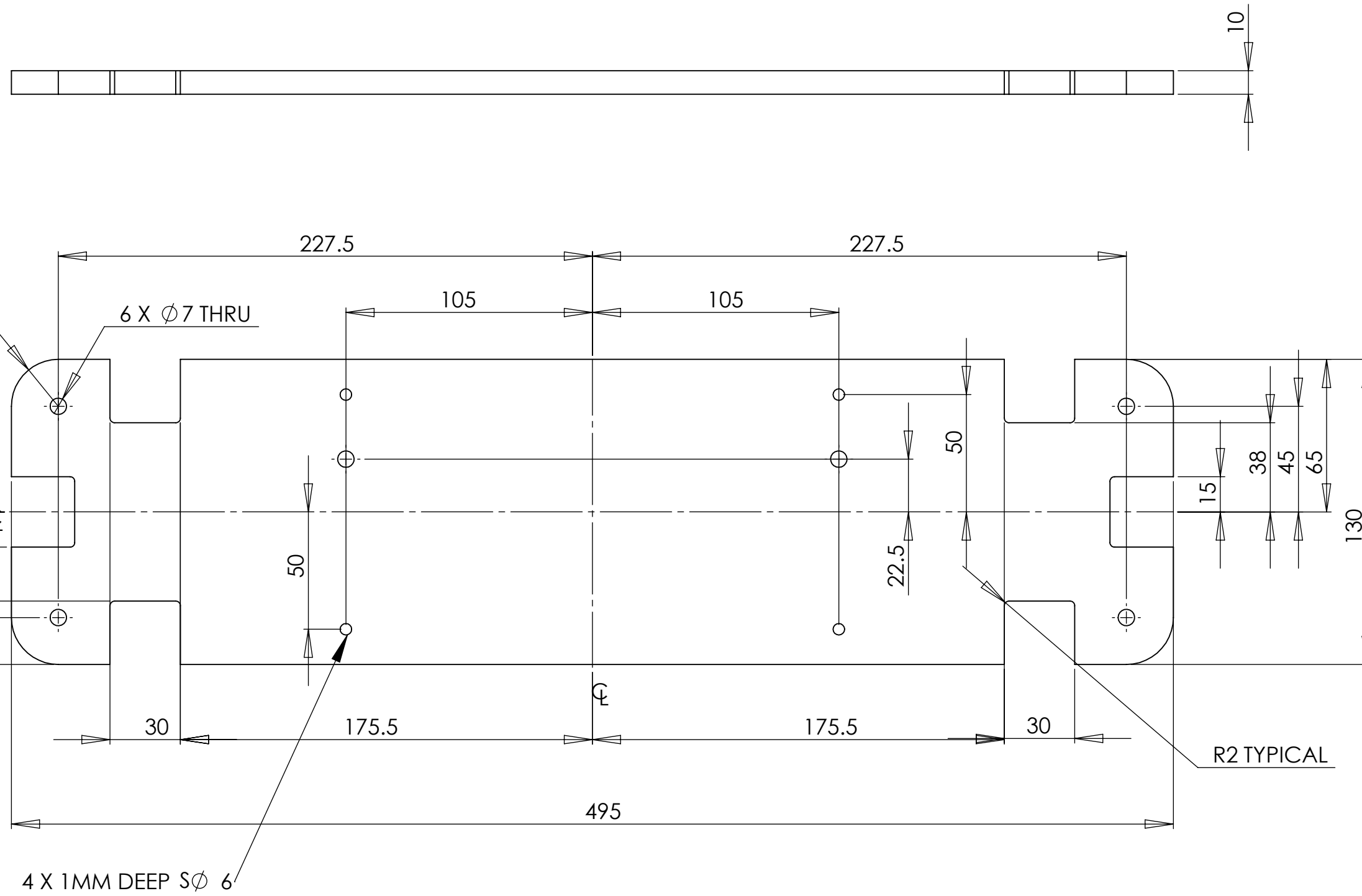
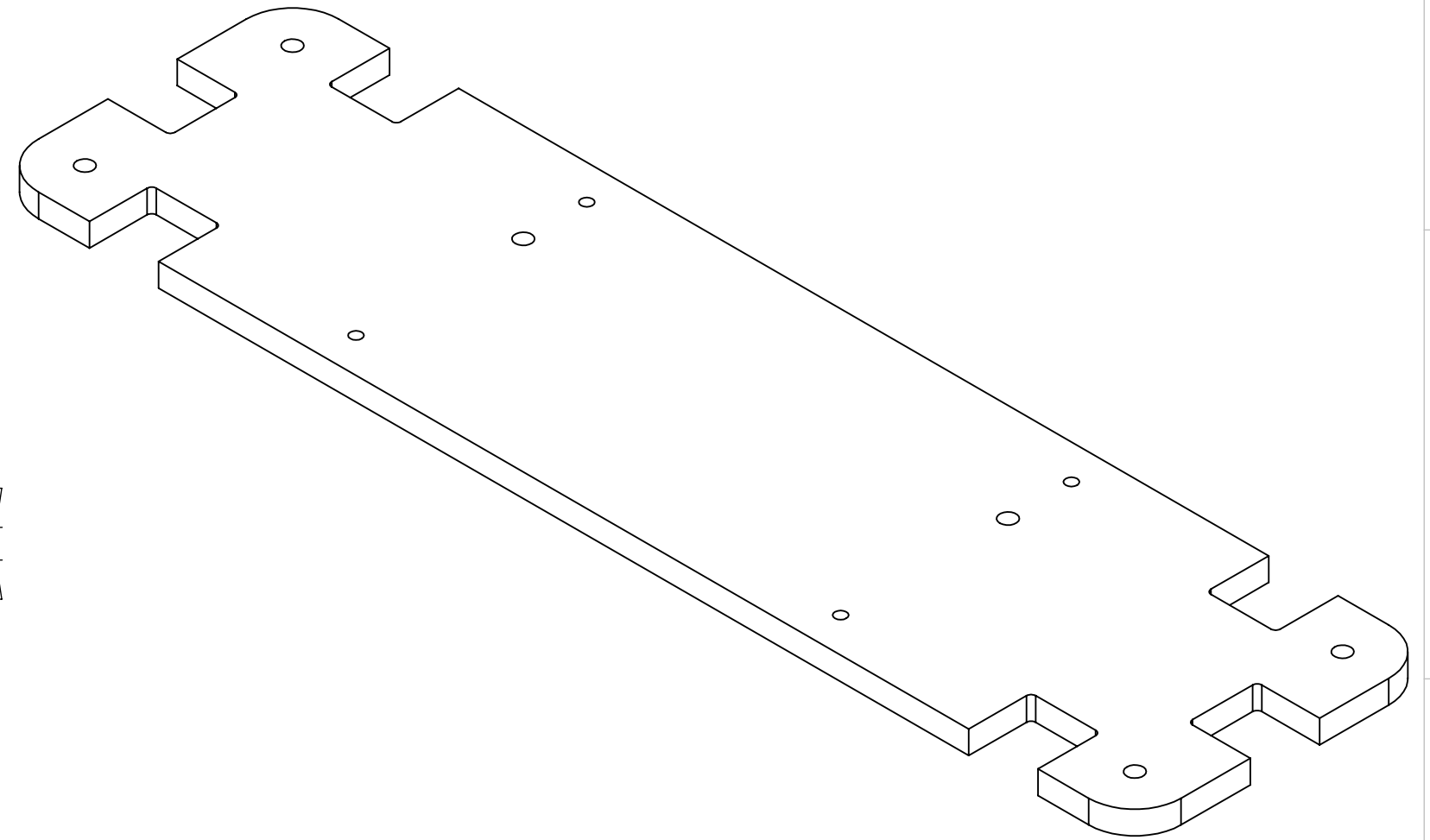

NOTES AND TOLERANCES: (UNLESS OTHERWISE SPECIFIED)

1. INTERPRET DRAWING PER ASME Y14.5-1994.
2. REMOVE ALL SHARP EDGES, R.02 MIN.
3. DO NOT SCALE FROM DRAWING.
4. ALL MACHINING FLUIDS MUST BE FULLY SYNTHETIC, FULLY WATER SOLUBLE AND FREE OF SULFUR, SILICONE, AND CHLORINE.

MATERIAL 6061-T6 Al **FINISH** 1.6 µm



SYSTEM ADVANCED LIGO **SUB-SYSTEM** SUS

NEXT ASSY

PART NAME			UPPER SUPPORT PLATE		
DESIGNER	L.CUNNINGHAM	16/06/2009	SIZE	DWG. NO.	REV.
DRAFTER	L.Cunningham		c	D0901034	v2
CHECKER			SCALE: 1:2	PROJECTION:	SHEET 1 OF 1
APPROVAL					