

REV.	DATE	DCN #	DRAWING TREE #
v1	05 AUG 2009	E0900172	E0900242
-		-	-
-		-	-

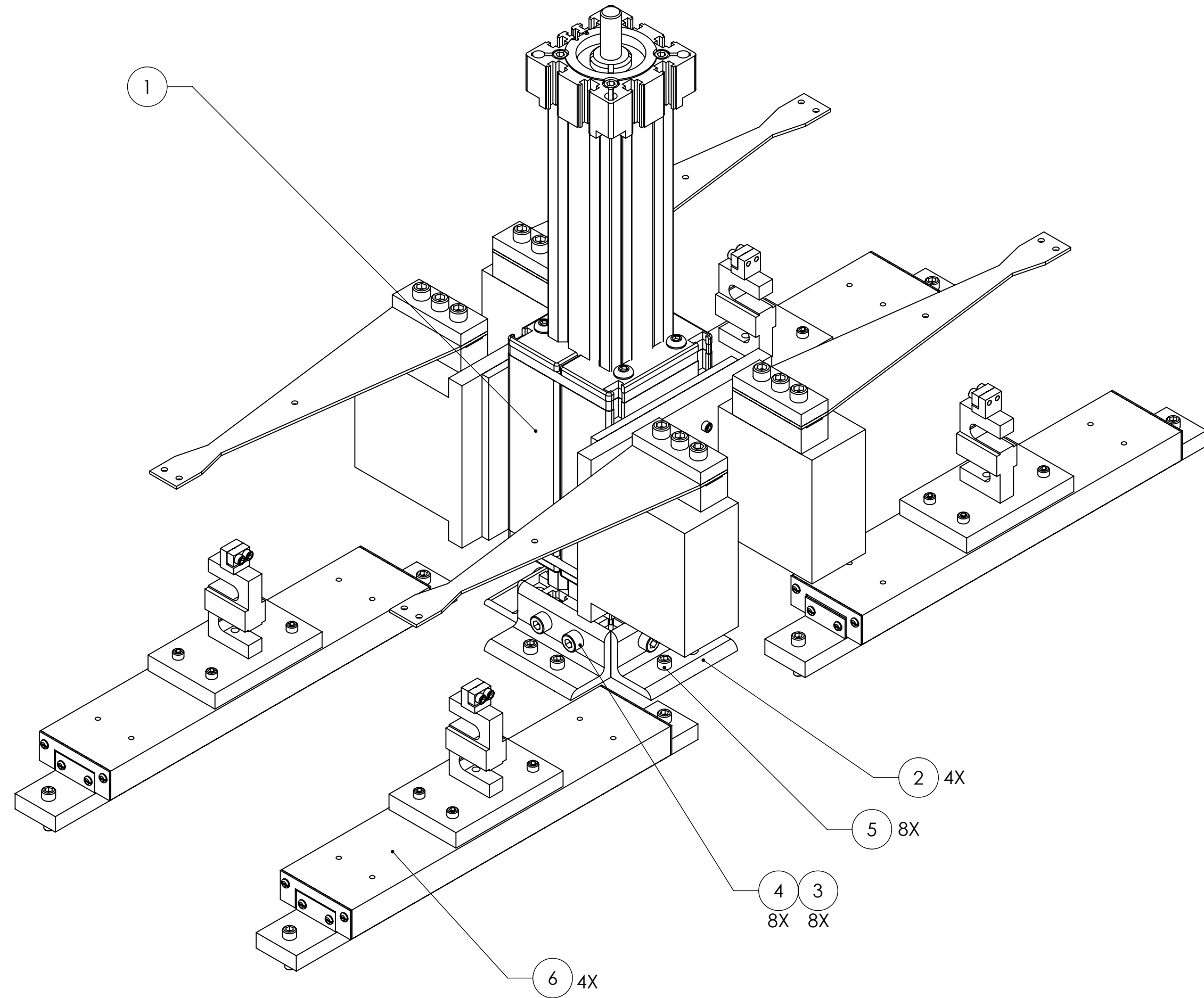

ITEM NO.	PART NUMBER	DESCRIPTION	MATERIAL	REQ	SPARE	TOTAL
6	D0901250	BALL SLIDE ASSEMBLY	N/A	4	-	4
5	-	SCREW, SOCKET HEAD CAP, 1/4-20 UNC-2A X 0.75 LONG	300 SSSL	8	2	10
4	-	SCREW, SOCKET HEAD CAP, METRIC, M8 X 14 LONG	300 SSSL	8	2	10
3	-	M8 T-NUT (NOOK)	SSTL	8	-	8
2	D0901246	ACTUATOR MOUNT	6061-T6 Al	4	-	4
1	D0901249	Actuator Assembly	N/A	1	-	1
PARTS LIST						

CALIFORNIA INSTITUTE OF TECHNOLOGY MASSACHUSETTS INSTITUTE OF TECHNOLOGY		PART NAME BLADE SPRING CHARACTERIZATION STAND				
SYSTEM ADVANCED LIGO	SUB-SYSTEM SUS	DESIGNER R. GIGLIO	25 JUN 2009	SIZE c	DWG. NO. D0901251	REV. v1
NEXT ASSY TOP LEVEL		DRAFTER W. RASCH	31 JUL 2009	SCALE: NFS		PROJECTION:
		CHECKER M. MEYER	31 JUL 2009	SHEET 1 OF 1		
		APPROVAL				